

Model J
(Machine Code: G060)

SERVICE MANUAL

February 23rd, 2001
Subject to change

IMPORTANT SAFETY NOTICES

PREVENTION OF PHYSICAL INJURY

1. Before disassembling or assembling parts of the printer and peripherals, make sure that the printer power cord is unplugged.
2. The wall outlet should be near the printer and easily accessible.
3. If any adjustment or operation check has to be made with exterior covers off or open while the main switch is turned on, keep hands away from electrified or mechanically driven components.
4. The printer drives some of its components when it completes the warm-up period. Be careful to keep hands away from the mechanical and electrical components as the printer starts operation.
5. The inside and the metal parts of the fusing unit become extremely hot while the printer is operating. Be careful to avoid touching those components with your bare hands.

HEALTH SAFETY CONDITIONS

Toner and developer are non-toxic, but if you get either of them in your eyes by accident, it may cause temporary eye discomfort. Try to remove with eye drops or flush with water as first aid. If unsuccessful, get medical attention.

OBSERVANCE OF ELECTRICAL SAFETY STANDARDS

1. The printer and its peripherals must be serviced by a customer service representative who has completed the training course on those models.
2. The NVRAM module (option) installed on the controller has a lithium battery which can explode if replaced incorrectly. Replace the NVRAM only with an identical one. The manufacturer recommends replacing the entire NVRAM. Do not recharge or burn this battery. Used NVRAM must be handled in accordance with local regulations.

SAFETY AND ECOLOGICAL NOTES FOR DISPOSAL

1. Do not incinerate toner bottles or used toner. Toner dust may ignite suddenly when exposed to an open flame.
2. Dispose of used toner, the maintenance unit which includes developer or the organic photoconductor in accordance with local regulations. (These are non-toxic supplies.)
3. Dispose of replaced parts in accordance with local regulations. When keeping used lithium batteries in order to dispose of them later, do not put more than 100 batteries per sealed box. Storing larger numbers or not sealing them apart may lead to chemical reactions and heat build-up.
4. When keeping used lithium batteries in order to dispose of them later, do not put more than 100 batteries per sealed box. Storing larger numbers or not sealing them apart may lead to chemical reactions and heat build-up.

LASER SAFETY

The Center for Devices and Radiological Health (CDRH) prohibits the repair of laser-based optical units in the field. The optical housing unit can only be repaired in a factory or at a location with the requisite equipment. The laser subsystem is replaceable in the field by a qualified Customer Engineer. The laser chassis is not repairable in the field. Customer engineers are therefore directed to return all chassis and laser subsystems to the factory or service depot when replacement of the optical subsystem is required.

WARNING

Use of controls, or adjustment, or performance of procedures other than those specified in this manual may result in hazardous radiation exposure.

WARNING

WARNING: Turn off the main switch before attempting any of the procedures in the Laser Optics Housing Unit section. Laser beams can seriously damage your eyes.

CAUTION MARKING:

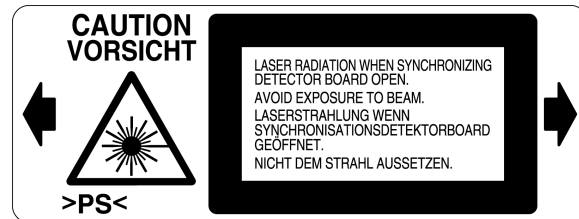

Trademarks

Microsoft[®], Windows[®], and MS-DOS[®] are registered trademarks of Microsoft Corporation in the United States and /or other countries.

PostScript[®] is a registered trademark of Adobe Systems, Incorporated.

PCL[®] is a registered trademark of Hewlett-Packard Company.

Ethernet[®] is a registered trademark of Xerox Corporation.

PowerPC[®] is a registered trademark of International Business Machines Corporation.

Other product names used herein are for identification purposes only and may be trademarks of their respective companies. We disclaim any and all rights involved with those marks.

TABLE OF CONTENTS

1	INSTALLATION	1-1
1.1	INSTALLATION REQUIREMENTS	1-1
1.1.1	ENVIRONMENT	1-1
1.1.2	MACHINE LEVEL	1-1
1.1.3	MACHINE SPACE REQUIREMENT	1-2
1.1.4	POWER REQUIREMENTS	1-2
1.2	OPTIONAL UNIT COMBINATIONS	1-3
1.3	INSTALLATION FLOW CHART	1-4
1.4	MACHINE INSTALLATION	1-5
1.5	OPTIONAL UNIT INSTALLATION.....	1-7
1.5.1	LIST OF OPTIONS	1-7
	Note for Transporting the Machine	1-7
1.5.2	PUNCH UNIT INSTALLATION	1-8
	Accessory Check	1-8
	Installation Procedure	1-9
2	PREVENTIVE MAINTENANCE.....	2-1
2.1	USER MAINTENANCE	2-1
2.2	SERVICE MAINTENANCE.....	2-3
3	REPLACEMENT AND ADJUSTMENT.....	3-1
3.1	SPECIAL TOOLS	3-1
3.2	IMAGE ADJUSTMENT	3-2
3.2.1	REGISTRATION.....	3-2
	Leading Edge.....	3-2
	Side to Side	3-2
	Adjustment Standard	3-2
	For standard trays, optional paper feed units, LCT and bypass feed table	3-2
	For duplex unit	3-2
	Adjustment Procedure	3-2
3.2.2	COLOR REGISTRATION	3-3
	Line Position Adjustment	3-3
	Adjustment for Line Speed of Fusing Unit.....	3-3
3.2.3	PRINTER GAMMA	3-4
	Adjustment Overview	3-4
	Adjustment Procedure	3-4
3.3	EXTERIOR COVERS	3-5
3.3.1	REAR COVER AND UPPER REAR COVER	3-5
3.3.2	PAPER EXIT TRAY	3-5
3.3.3	UPPER RIGHT COVER	3-5
3.3.4	FRONT COVER	3-6
3.3.5	LEFT COVER AND REAR LEFT COVER	3-6
3.3.6	UPPER LEFT COVER AND OPERATION PANEL	3-7
3.4	LASER OPTICS	3-8

3.4.1	CAUTION DECAL LOCATIONS.....	3-8
3.4.2	LASER OPTICS HOUSING UNIT	3-9
	Adjustments after Replacing the Laser Optics Housing Unit.....	3-11
3.4.3	POLYGON MIRROR MOTOR.....	3-12
3.4.4	LASER SYNCHRONIZING DETECTOR BOARDS	3-12
3.5	PCU AND DEVELOPMENT UNIT	3-13
3.6	PAPER FEED.....	3-14
3.6.1	PICK-UP, FEED, AND SEPARATION ROLLERS	3-14
	Tray 1 and Tray 2	3-14
	By-pass Tray.....	3-14
3.6.2	PAPER WIDTH DETECTION BOARD	3-15
3.6.3	VERTICAL TRANSPORT SENSOR.....	3-15
3.6.4	RIGHT DOOR UNIT	3-16
3.6.5	REGISTRATION SENSOR AND RELAY SENSOR	3-17
3.6.6	PAPER FEED CLUTCHES.....	3-17
3.6.7	BY-PASS FEED CLUTCH.....	3-18
3.6.8	TRAY LIFT MOTOR	3-18
3.7	TRANSFER AND PAPER TRANSPORT UNIT	3-19
3.7.1	TRANSFER UNIT.....	3-19
3.7.2	TRANSFER BELT CLEANING UNIT.....	3-20
3.7.3	CLEANING BLADE AND CLEANING ROLLER	3-21
3.7.4	TRANSFER BELT	3-22
3.8	FUSING.....	3-24
3.8.1	FUSING UNIT.....	3-24
3.8.2	OIL SUPPLY UNIT	3-25
3.8.3	PAPER EXIT	3-25
3.9	ELECTRICAL COMPONENTS.....	3-26
3.9.1	MOVING THE CONTROLLER BOX OUT OF THE WAY	3-26
3.9.2	MOVING THE HIGH VOLTAGE SUPPLY UNIT - C, B OUT OF THE WAY.....	3-26
3.9.3	CONTROLLER AND BCU	3-27
3.9.4	NVRAM REPLACEMENT PROCEDURE	3-28
	NVRAM for BCU	3-28
	NVRAM for Controller	3-28
	NVRAMs for both BCU and Controller	3-28
3.9.5	REMOVING THE HIGH VOLTAGE SUPPLY BOARD - C, B	3-29
3.9.6	PSU	3-29
3.10	DRIVE UNIT	3-30
3.10.1	REGISTRATION CLUTCH	3-30
3.10.2	DEVELOPMENT CLUTCHES	3-30
3.10.3	DEVELOPMENT DRIVE MOTOR - CMY	3-31
3.10.4	DRUM DRIVE MOTOR - CMY AND DRUM DRIVE MOTOR - K.....	3-31
3.10.5	DEVELOPMENT DRIVE MOTOR - K.....	3-32
4	TROUBLESHOOTING	4-1
4.1	PROCESS CONTROL ERROR CONDITIONS	4-1
4.1.1	DEVELOPER INITIALIZATION RESULT	4-1
4.1.2	PROCESS CONTROL SELF-CHECK RESULT	4-1

4.1.3	LINE POSITION ADJUSTMENT RESULT	4-2
4.2	SERVICE CALL CONDITIONS	4-5
4.2.1	SUMMARY	4-5
	SC Classification.....	4-5
4.3	SC TABLE	4-7
4.4	ELECTRICAL COMPONENT DEFECTS	4-32
4.4.1	SENSORS.....	4-32
4.5	BLOWN FUSE CONDITIONS	4-33
4.6	LEDS (BCU).....	4-33
5	SERVICE TABLES.....	5-1
5.1	SERVICE PROGRAM MODE.....	5-1
5.1.1	ENABLING AND DISABLING SERVICE PROGRAM MODE	5-1
	Entering the Service Mode.....	5-1
	Accessing the Required Program	5-2
	Inputting a Value or Setting for a Service Program.....	5-2
	Exiting Service Mode	5-2
5.2	PRINTER CONTROLLER SERVICE MODE	5-3
5.2.1	REMARKS.....	5-3
	Display on the Control Panel Screen	5-3
	Others	5-4
5.2.2	SERVICE MODE MENU (“1. SERVICE”)	5-5
5.2.3	BIT SWITCH PROGRAMMING	5-6
5.3	PRINTER ENGINE SERVICE MODE.....	5-7
5.3.1	SERVICE MODE TABLE (“2. ENGINE”)	5-7
5.3.2	INPUT CHECK TABLE	5-44
	Table 1: Paper Height Sensor.....	5-46
	Table 2: Paper Size Switch (Tray 2)	5-46
	Table 3: Paper Size (By-pass Table)	5-46
5.3.3	OUTPUT CHECK TABLE	5-47
5.3.4	TEST PATTERN (SP5-997)	5-51
5.4	FIRMWARE UPDATE PROCEDURE.....	5-52
5.4.1	TYPE OF FIRMWARE.....	5-52
5.4.2	ERROR RECOVERY.....	5-52
	Engine Firmware/Controller NIB Firmware	5-52
	Controller System Firmware:	5-52
5.4.3	CONTROLLER/ENGINE FIRMWARE UPGRADE	5-53
5.5	CONTROLLER SELF-DIAGNOSTICS	5-54
5.5.1	OVERVIEW	5-54
5.5.2	DETAILED SELF-DIAGNOSTICS	5-55
5.6	USER PROGRAM MODE	5-56
5.7	DIP SWITCHES.....	5-57
	Controller Board.....	5-57
6	DETAILED SECTION DESCRIPTIONS	6-1
6.1	OVERVIEW	6-1
6.1.1	COMPONENT LAYOUT	6-1
6.1.2	PAPER PATH.....	6-2
6.1.3	DRIVE LAYOUT	6-3

6.1.4	BOARD STRUCTURE.....	6-4
	Overview.....	6-4
	Descriptions.....	6-5
6.1.5	PRINTING PROCESS.....	6-6
6.2	PROCESS CONTROL.....	6-8
6.2.1	OVERVIEW.....	6-8
6.2.2	POTENTIAL CONTROL.....	6-8
	Overview.....	6-8
	Process Control Self Check.....	6-9
6.2.3	PROCESS CONTROL SELF CHECK PROCEDURE.....	6-10
	Step 1: VSG Adjustment.....	6-10
	Step 2: ID Sensor Solid Pattern Generation.....	6-11
	Step 3: Sensor Pattern Detection.....	6-11
	Step 4: Toner Amount Calculation.....	6-11
	Step 5: VD, VB, VL Selection and VREF Adjustment.....	6-11
	Step 6: ID Sensor Highlight Pattern Generation.....	6-12
	Step 7: Sensor Pattern Density Detection.....	6-12
	Step 8: VL (LD Power) Selection.....	6-13
6.2.4	TONER SUPPLY CONTROL.....	6-14
	Overview.....	6-14
	Toner Supply Control Modes.....	6-14
6.2.5	TONER NEAR END/TONER END DETECTION.....	6-15
	Introduction.....	6-15
	Toner Near End Detection.....	6-15
	Toner End Detection.....	6-15
	Toner End Recovery.....	6-15
6.2.6	DEVELOPER INITIALIZATION.....	6-16
6.3	LASER EXPOSURE.....	6-17
6.3.1	OVERVIEW.....	6-17
6.3.2	OPTICAL PATH.....	6-18
6.3.3	LASER SYNCHRONIZING DETECTOR.....	6-19
	Overview.....	6-19
	Main Scan Start Detection.....	6-19
	Clock Frequency Adjustment.....	6-19
6.3.4	DUAL BEAM WRITING.....	6-20
	Dual Beam Mechanism.....	6-20
	Laser Beam Pitch Change Mechanism.....	6-20
6.3.5	LD SAFETY SWITCH.....	6-21
6.3.6	AUTOMATIC LINE POSITION ADJUSTMENTS.....	6-22
	Overview.....	6-22
	Sub Scan Line Position for YCM.....	6-23
	Main Scan Line Position for KYCM.....	6-23
	Magnification Adjustment.....	6-23
	Main Scan Skew Adjustment.....	6-24
6.4	PHOTOCONDUCTOR UNIT.....	6-25
6.4.1	OVERVIEW.....	6-25
6.4.2	DRIVE.....	6-26
6.4.3	DRUM CHARGE AND QUENCHING.....	6-27
6.4.4	DRUM CLEANING.....	6-28

6.4.5	WASTE TONER COLLECTION	6-29
6.4.6	WASTE TONER BOTTLE FULL DETECTION	6-30
6.4.7	PCU DETECTION (DEVELOPMENT UNIT DETECTION)	6-31
6.5	DEVELOPMENT	6-32
6.5.1	OVERVIEW	6-32
6.5.2	DRIVE.....	6-33
6.5.3	DEVELOPER AGITATION	6-34
6.5.4	DEVELOPMENT BIAS	6-35
6.5.5	DEVELOPMENT UNIT DETECTION.....	6-35
6.5.6	TONER SUPPLY MECHANISM.....	6-36
	Overview.....	6-36
	Toner Agitation	6-36
	Toner Transport.....	6-37
6.5.7	TONER CARTRIDGE DETECTION	6-38
6.6	PAPER FEED.....	6-39
6.6.1	OVERVIEW	6-39
6.6.2	DRIVE – TRAYS 1 AND 2.....	6-40
6.6.3	PAPER LIFT – TRAYS 1 & 2.....	6-41
6.6.4	PAPER SIZE DETECTION – TRAYS 1 & 2.....	6-42
6.6.5	PAPER HEIGHT DETECTION – TRAYS 1 & 2.....	6-43
6.6.6	PAPER END DETECTION – TRAYS 1 & 2.....	6-43
6.6.7	REGISTRATION.....	6-44
6.6.8	PAPER FEED LINE SPEED.....	6-45
6.6.9	BY-PASS TRAY.....	6-46
6.7	IMAGE TRANSFER AND PAPER SEPARATION	6-47
6.7.1	OVERVIEW	6-47
6.7.2	TRANSFER BELT DRIVE	6-48
6.7.3	TRANSFER AND CLEANING CURRENT	6-49
6.7.4	TRANSFER BELT CLEANING	6-50
6.7.5	TRANSFER BELT CONTACT	6-51
	Mechanism	6-51
	ACS (Auto Color Sensing) Mode	6-52
6.8	FUSING.....	6-53
6.8.1	OVERVIEW	6-53
6.8.2	FUSING UNIT DRIVE.....	6-54
6.8.3	FUSING TEMPERATURE CONTROL.....	6-55
	Fusing Temperatures.....	6-55
	Temperature Corrections.....	6-56
	Overheat Protection.....	6-56
6.8.4	OIL SUPPLY AND CLEANING.....	6-57
6.8.5	NEW FUSING OIL SUPPLY UNIT DETECTION.....	6-58
6.8.6	NEW FUSING UNIT DETECTION.....	6-59
6.8.7	ENERGY SAVER MODE.....	6-60
	Level 1 Energy Saver Mode.....	6-60
	Level 2 Energy Saver Mode.....	6-60
6.9	PAPER EXIT	6-61
6.9.1	OVERVIEW	6-61
6.9.2	PAPER OVERFLOW DETECTION	6-62
6.10	CONTROLLER.....	6-63

6.10.1 OVERVIEW	6-63
6.10.2 BOARD LAYOUT.....	6-65
6.10.3 PRINT DATA PROCESSING	6-66
RPCS Driver	6-66
PCL5c Driver	6-66
PS3 Driver	6-67
CMS (Color Management System)	6-67
Gray Correction	6-67
BG/UCR (Black Generation/Under Color Removal).....	6-67
Gamma Correction	6-67
Toner Limitation	6-68
Dither Processing and ROP/RIP	6-68
6.10.4 CONTROLLER FUNCTIONS	6-69
Sample Print	6-69
Locked Print.....	6-69
Paper Source Selection	6-70
Tray Priority (Auto Tray Select).....	6-70
Tray Lock.....	6-70
Manual Tray Select.....	6-70
Auto Continue	6-71
Overview.....	6-71
Auto Tray Select	6-71
Manual Tray Select.....	6-71
Paper Output Tray	6-72
Output Tray Selected.....	6-72
Sequential Stacking	6-72
Stapling.....	6-73
Punching.....	6-73
6.11 IEEE1394 INTERFACE	6-74
6.11.1 SPECIFICATIONS.....	6-74
Hardware Specification	6-74
System Requirements.....	6-74
6.11.2 IEEE1394	6-74
6.11.3 BLOCK DIAGRAM.....	6-75
6.11.4 PIN ASSIGNMENT	6-75
6.11.5 REMARKS ABOUT THIS INTERFACE KIT.....	6-76
6.11.6 TROUBLESHOOTING NOTES	6-76

PERIPHERALS

DUPLEX UNIT (Machine Code: G571)

1 REPLACEMENT AND ADJUSTMENT.....	G571-1
1.1 DUPLEX INVERTER UNIT	G571-1
1.1.1 TOP COVER	G571-1

1.1.2	DUPLEX CONTROL BOARD	G571-1
1.1.3	DUPLEX INVERTER MOTOR 1	G571-2
1.1.4	DUPLEX INVERTER MOTOR 2 AND SWITCH	G571-2
1.1.5	EXIT SENSOR 3 AND DUPLEX INVERTER SENSOR.....	G571-3
1.1.6	EXIT SENSOR 1 AND 2	G571-3
1.2	DUPLEX FEED UNIT	G571-4
1.2.1	DUPLEX DRIVE BOARD.....	G571-4
1.2.2	DUPLEX FEED MOTOR	G571-4
1.2.3	DUPLEX FEED SENSOR.....	G571-5
2	DETAILED DESCRIPTIONS	G571-6
2.1	OVERVIEW	G571-6
2.2	DUPLEX OPERATION.....	G571-7
2.2.1	UP TO A4/LT(8 1/2" X 11") LEF	G571-7
2.2.2	LARGER THAN A4/LT(8 1/2" X 11") LEF	G571-7
2.3	DUPLEX INVERTER UNIT.....	G571-8
2.3.1	DRIVE.....	G571-8
2.3.2	FEED TO EXTERNAL EXIT TRAY (NON-DUPLEX MODE)	G571-9
2.3.3	FEED TO DUPLEX FEED UNIT	G571-10
2.3.4	FEED TO TWO-TRAY FINISHER	G571-11
	With Optional One-Tray Paper Feed Unit	G571-11
	With Optional LCT or Two-Tray Paper Feed Unit	G571-11
2.4	DUPLEX FEED UNIT	G571-12
2.4.1	DRIVE.....	G571-12
2.4.2	FEED-IN AND FEED-OUT	G571-12

ONE-TRAY PAPER FEED UNIT (Machine Code: G567)

1	REPLACEMENT AND ADJUSTMENT.....	G567-1
1.1	COVER REPLACEMENT	G567-1
1.2	ROLLER REPLACEMENT	G567-2
1.2.1	PAPER FEED, SEPARATION, AND PICK-UP ROLLERS	G567-2
1.3	PAPER FEED MOTOR AND MAIN BOARD	G567-3
1.4	TRAY LIFT MOTOR	G567-4
1.5	PAPER FEED CLUTCH	G567-4
1.6	PAPER FEED UNIT REPLACEMENT.....	G567-5
2	DETAILED DESCRIPTIONS	G567-6
2.1	OVERVIEW	G567-6
2.1.1	MECHANICAL COMPONENT LAYOUT.....	G567-6
2.1.2	ELECTRICAL COMPONENT LAYOUT	G567-7
2.1.3	DRIVE LAYOUT	G567-8

TWO-TRAY PAPER FEED UNIT (Machine Code: G568)

1	REPLACEMENT AND ADJUSTMENT.....	G568-1
----------	--	---------------

1.1 COVER REPLACEMENT	G568-1
1.2 ROLLER REPLACEMENT	G568-2
1.2.1 PAPER FEED, SEPARATION, AND PICK-UP ROLLERS	G568-2
1.3 PAPER FEED MOTOR AND MAIN BOARD	G568-3
1.4 TRAY LIFT MOTORS	G568-4
1.5 PAPER FEED CLUTCHES	G568-4
1.6 PAPER FEED UNIT REPLACEMENT	G568-5
2 DETAILED DESCRIPTIONS	G568-6
2.1 OVERVIEW	G568-6
2.1.1 MECHANICAL COMPONENT LAYOUT	G568-6
2.1.2 ELECTRICAL COMPONENT LAYOUT	G568-7
2.1.3 DRIVE LAYOUT	G568-8

LARGE CAPACITY TRAY (Machine Code: G569)

1 REPLACEMENT AND ADJUSTMENT	G569-1
1.1 DETACHING THE TRAY FROM THE MAINFRAME	G569-1
1.2 REAR FENCE HP SENSOR	G569-1
1.3 CHANGING THE TRAY PAPER SIZE	G569-2
1.4 LEFT TRAY PAPER END SENSOR	G569-3
1.5 TRAY LIFT MOTOR	G569-4
1.6 TRAY MOTOR AND STACK TRANSPORT CLUTCH	G569-5
1.7 PAPER FEED CLUTCH	G569-6
1.8 PAPER FEED UNIT	G569-7
1.9 UPPER LIMIT, RIGHT TRAY PAPER END, AND RELAY SENSORS	G569-8
1.10 PICK-UP/PAPER FEED/SEPARATION ROLLER	G569-9
2 DETAILED SECTION DESCRIPTIONS	G569-10
2.1 OVERVIEW	G569-10
2.1.1 MECHANICAL COMPONENT LAYOUT	G569-10
2.1.2 ELECTRICAL COMPONENT LAYOUT	G569-11
2.2 PAPER FEED	G569-12
2.3 SEPARATION ROLLER AND PICK-UP ROLLER RELEASE	G569-13
2.4 TRAY LIFT	G569-14
2.5 NEAR END/END DETECTION	G569-15
2.6 PAPER STACK TRANSPORT MECHANISM	G569-16
2.7 RIGHT TRAY PAPER END DETECTION	G569-17

TWO-TRAY FINISHER (Machine Code: G565)

1 REPLACEMENT AND ADJUSTMENT	G565-1
1.1 COVERS	G565-1
1.1.1 EXTERNAL COVERS	G565-1
1.1.2 INNER COVER	G565-1

1.2	POSITIONING ROLLER.....	G565-2
1.3	TRAY 1 EXIT SENSOR.....	G565-2
1.4	ENTRANCE SENSOR/STAPLER TRAY ENTRANCE SENSOR	G565-3
1.5	STAPLER TRAY.....	G565-3
1.6	UPPER STACK HEIGHT SENSORS/ TRAY 1 UPPER LIMIT SWITCH	G565-4
1.7	EXIT GUIDE PLATE MOTOR.....	G565-5
1.8	LIFT MOTORS	G565-5
1.9	LOWER EXIT SENSOR	G565-7
1.10	LOWER STACK HEIGHT SENSORS	G565-8
1.11	TRAY 2 SHUNT POSITION SENSOR	G565-8
1.12	STAPLER UNIT.....	G565-9
1.13	STAPLER ROTATION HP SENSOR.....	G565-9
1.14	TRAY 1 INTERIOR.....	G565-10
1.14.1	TRAY 1 COVERS	G565-10
	tray Shift Sensors and tray release sensor	G565-11
1.14.3	TRAY 1 SHIFT MOTOR	G565-11
1.14.4	BACK FENCE LOCK CLUTCH	G565-11
1.15	FINISHER MAIN BOARD	G565-12
1.16	PUNCH HOLE POSITION ADJUSTMENT.....	G565-12
2	TROUBLESHOOTING	G565-13
2.1	JAM DETECTION.....	G565-13
3	SERVICE TABLES.....	G565-14
3.1	DIP SWITCH SETTINGS	G565-14
3.2	TEST POINTS	G565-14
3.3	FUSES	G565-14
4	DETAILED DESCRIPTIONS.....	G565-15
4.1	GENERAL LAYOUT	G565-15
4.2	DRIVE LAYOUT	G565-16
4.3	JUNCTION GATES	G565-17
4.4	TRAY SHIFTING	G565-18
4.4.1	TRAY SHIFT MECHANISMS	G565-18
	Tray 1 (Upper Tray)	G565-18
	Tray 2 (Lower Tray)	G565-19
4.5	TRAY UP/DOWN MECHANISMS	G565-20
4.5.1	TRAY 1	G565-20
	Introduction	G565-20
	Normal and sort/stack modes	G565-20
	Staple Mode.....	G565-21
	Tray 1 release mechanism.....	G565-22
4.5.2	TRAY 2.....	G565-23
4.5.3	PRE-STACK MECHANISM	G565-24
4.6	JOGGER UNIT PAPER POSITIONING MECHANISM.....	G565-25
	Vertical Paper Alignment	G565-25
	Horizontal Paper Alignment	G565-25
4.7	STAPLER MECHANISM	G565-26

4.7.1 STAPLER MOVEMENT.....	G565-26
Stapler Rotation	G565-26
Side-to-Side Movement	G565-26
4.7.2 STAPLER	G565-27
4.7.3 FEED OUT AND TRANSPORT	G565-28
4.8 PUNCH UNIT (OPTIONAL).....	G565-29
4.8.1 PUNCH DRIVE MECHANISM	G565-29
4.8.2 PUNCH WASTE COLLECTION	G565-30

FOUR-BIN MAILBOX (Machine Code: G566)

1 REPLACEMENT AND ADJUSTMENT.....	G566-1
1.1 EXTERIOR COVER REMOVAL.....	G566-1
1.2 TRAY PAPER/OVERFLOW/VERTICAL TRANSPORT SENSORS.....	G566-2
1.3 MAIN MOTOR REPLACEMENT	G566-3
2 DETAILED DESCRIPTIONS	G566-4
2.1 COMPONENT LAYOUT	G566-4
2.1.1 MECHANICAL COMPONENT LAYOUT.....	G566-4
2.1.2 DRIVE LAYOUT	G566-4
2.2 ELECTRICAL COMPONENT DESCRIPTIONS	G566-5
2.3 BASIC OPERATION.....	G566-6
2.4 PAPER OVERFLOW DETECTION	G566-7

SPECIFICATIONS.....	SPEC-1
1 GENERAL SPECIFICATIONS.....	SPEC-1
1.1 SUPPORTED PAPER SIZES.....	SPEC-3
1.1.1 PAPER FEED.....	SPEC-3
1.1.2 PAPER EXIT	SPEC-4
2 SOFTWARE ACCESSORIES	SPEC-5
2.1 PRINTER DRIVERS	SPEC-5
2.2 UTILITY SOFTWARE	SPEC-5
3 MACHINE CONFIGURATION.....	SPEC-6
4 OPTIONAL EQUIPMENT	SPEC-8
4.1 500-SHEET TRAY	SPEC-8
4.2 1000-SHEET TRAY	SPEC-8
4.3 2000-SHEET LARGE CAPACITY TRAY	SPEC-8
4.4 TWO-TRAY FINISHER & PUNCH UNIT	SPEC-9
4.5 FOUR-BIN MAILBOX	SPEC-10

1. INSTALLATION

1.1 INSTALLATION REQUIREMENTS

1.1.1 ENVIRONMENT

1. Temperature Range: 10°C to 32°C (50°F to 89.6°F)
2. Humidity Range: 15% to 80% RH
3. Ambient Illumination: Less than 2,000 lux (do not expose to direct sunlight)
4. Ventilation: 3 times/hr/person or more
5. Avoid exposing the machine to sudden temperature changes, which include:
 - 1) Direct cool air from an air conditioner
 - 2) Direct heat from a heater
6. Avoid installing the machine in areas that might be exposed to corrosive gas.
7. Install the machine at a location lower than 2,500 m (8,200 ft.) above sea level.
8. Install the machine on a strong, level base. (Inclination on any side must be no more than 5 mm.)
9. Avoid installing the machine in areas that may be subjected to strong vibration.

1.1.2 MACHINE LEVEL

- Front to back: Within 5 mm (0.2")
Right to left: Within 5 mm (0.2")

1.1.3 MACHINE SPACE REQUIREMENT

Place the machine near the power source, providing clearance as shown.

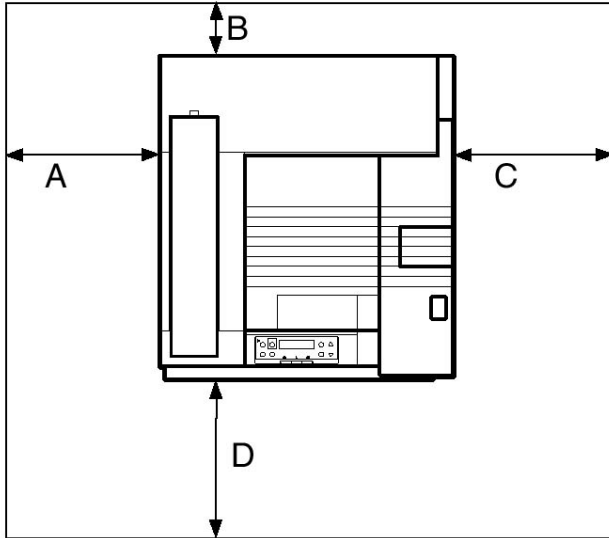

- A: Over 460 mm (18")
- B: Over 100 mm (4")
- C: Over 550 mm (22")
- D: Over 700 mm (28")

G0601103.JPG

1.1.4 POWER REQUIREMENTS

⚠ CAUTION

1. Insert firmly the plug in the outlet.
2. Avoid using an outlet extension plug or cord.
3. Ground the machine.

1. Input voltage level: 120 V, 60 Hz: More than 10 A
 220 V ~ 240 V, 50 Hz/60 Hz: More than 6 A
2. Permissible voltage fluctuation: $\pm 10\%$
3. Do not put or place anything on the power cord.

1.2 OPTIONAL UNIT COMBINATIONS

Item No.	Options	Alternative	Required
1	PFU (1 Tray)	Items 2, 3	
2	PFU (2 Trays)	Items 1, 3	
3	LCT	Items 1, 2	
4	Two-tray finisher	Item 6	<ul style="list-style-type: none"> • Item 7 • Item 8 (Total 128 MB needed) or 9 • Item 1, 2 or 3
5	3 types of punch kit		Item 4
6	Four-bin mailbox	Items 4, 5	
7	Duplex unit		
8	3 types of memory DIMM		
9	HDD		
10	IEEE 1394		Item 8
11	NVRAM		

NOTE: Two memory DIMMs (up to 384 MB) can be installed.

1.3 INSTALLATION FLOW CHART

The following flow chart shows how to install the optional units more efficiently.

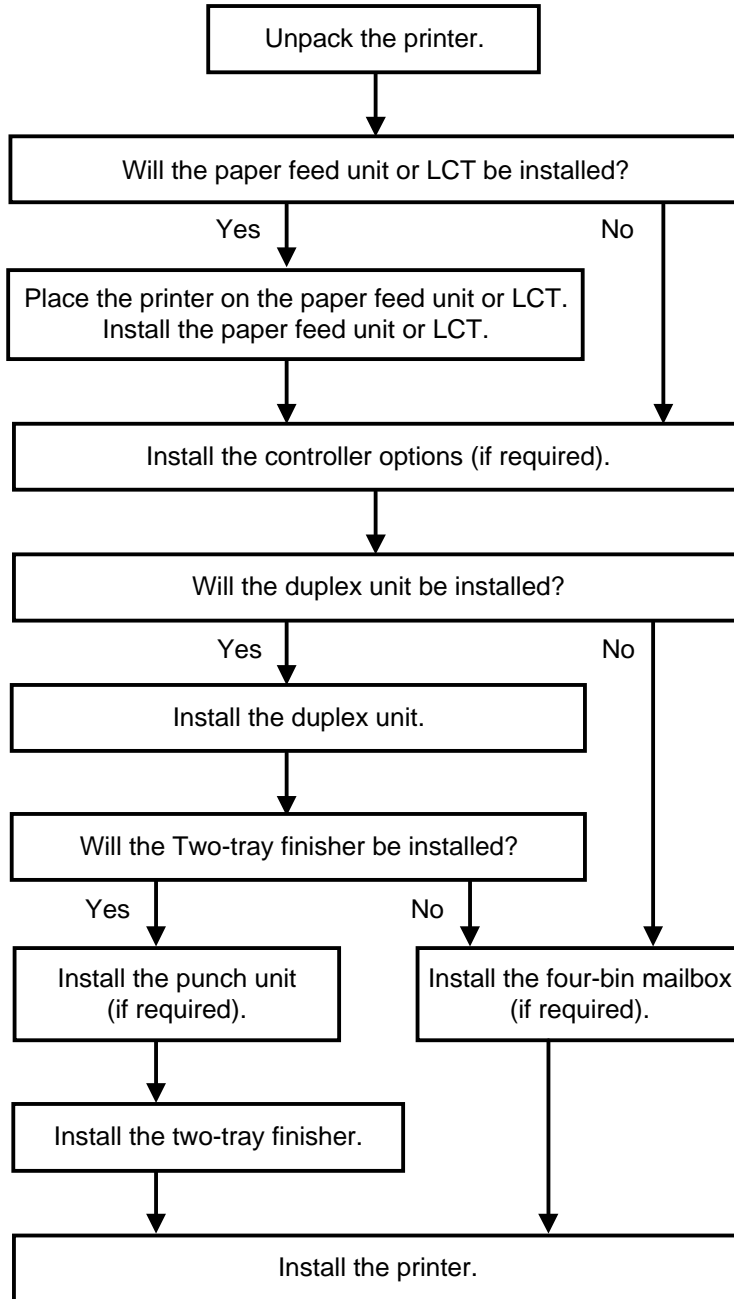

G0601002.WMF

- Two-tray Finisher: Needs the duplex unit, HDD or at least 128 MB of memory, and a paper tray unit or LCT.
- Punch Unit: Needs the finisher.
- IEEE1394 Board: Needs the memory DIMM.

1.4 MACHINE INSTALLATION

Refer to the Operating Instructions for details.

If the customer has a service contract, change the settings of the following SP modes depending on the contract type.

Item	SP No.	Function	Default
Meter charge	SP5-930-1	Specifies whether the meter charge mode is enabled or disabled. Meter charge mode enabled: <ul style="list-style-type: none"> • The Counter menu appears immediately after the Menu key is pressed. • The counter type selected by the counting method (SP5-045-1) can be displayed with the Counter menu. • The counter values can also be printed with the Counter menu. • The selected counter starts from a negative number. Meter charge mode disabled: <ul style="list-style-type: none"> • The Counter menu is not displayed. • The total counter starts from 0. 	Off
Counting method	SP5-045-1	Specifies whether the counting method used in meter charge mode is based on developments or prints. Important: This SP can only be done before the negative counters are reset with SP7-825-001	Developments
A3/11" x 17" double counting	SP5-104-1	Specifies whether the counter is doubled for A3/11" x 17" paper.	No: Single counting
PM warning display 1	SP5-930-3	Specifies whether the PM warning for PCUs and development units is displayed when the replacement time arrives. Type 1: Displayed Type 2: Not displayed	Type 1
PM warning display 2	SP5-930-4 to SP5-930-5	Specifies whether the PM warning for the paper feed roller and transfer unit is displayed.	Off:
Fax No. setting	SP5-812-2	Programs the service station fax number. The number is printed on the counter list when the meter charge mode is selected, so that the user can fax the counter data to the service station.	

Item	SP No.	Function	Default
Counter reset	SP7-825-1	Resets the counters to 0. Important: This must be done at installation after all the above settings have been finished. The negative counters used in meter charge mode will be reset to zero.	

NOTE: 1) The default setting for this machine is meter-charge mode off.
2) The meter-charge counter cannot be reset.

1.5 OPTIONAL UNIT INSTALLATION

1.5.1 LIST OF OPTIONS

The available options are listed below. Except for the punch unit, installation is explained in the Operating Instructions.

- Paper Feed Unit (500 sheets x 1)
- Paper Feed Unit (500 sheets x 2)
- Large Capacity Tray
- Two-tray Finisher
- Punch Unit
- Four-bin Mailbox
- DIMM Memory (64/128/256 MB)
- IEEE1394 Board
- HDD
- NVRAM

Note for Transporting the Machine

If it is difficult to slide the machine across the floor after installing the optional paper feed unit or LCT, remove the two stands with the following procedure.

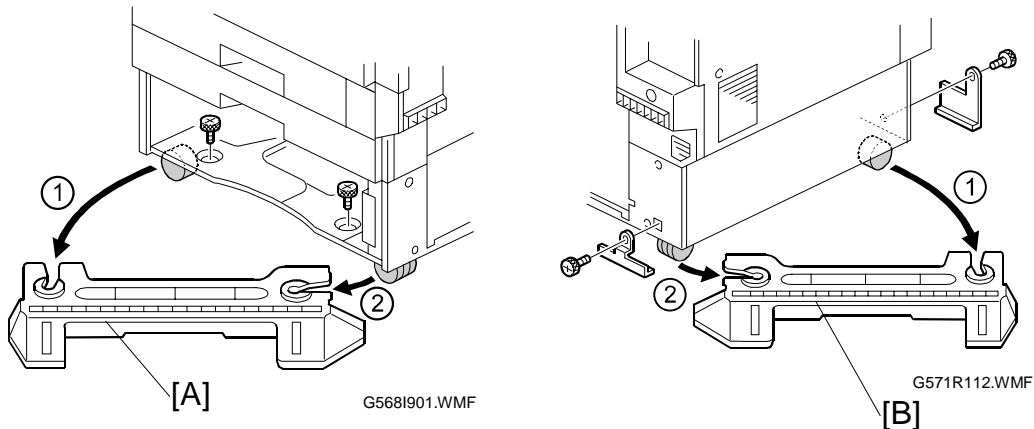

1. Remove all trays in the optional paper feed unit or LCT.
2. Remove the front stand [A] (⚙ x 2).
3. Remove the rear stand [B] (⚙ x 2, 2 brackets).

CAUTION: Reinstall the two stands in their original positions, or the machine might tip over when drawing out the paper trays and so on.

1.5.2 PUNCH UNIT INSTALLATION

Accessory Check

Check the quantity and condition of the accessories in the box against the following list:

Description	Q'ty
1. Punch unit.....	1
2. Sensor arm	1
3. Hopper	1
4. Step screw	1
5. Spring.....	1
6. Spacer (2 mm)	1
7. Spacer (1 mm)	1
8. Tapping screw.....	1
9. Tapping screw.....	2

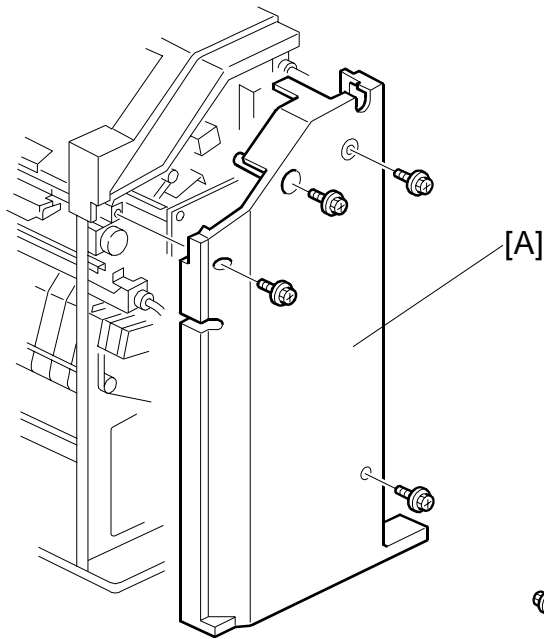
Installation Procedure

B3771102.WMF

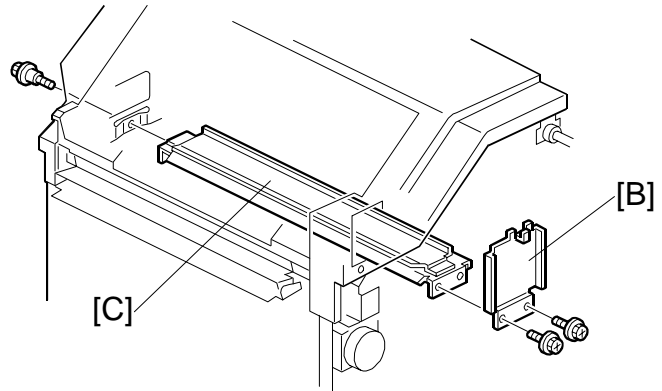

B3771103.WMF

⚠ CAUTION

Switch off the main machine and unplug its power cord. If the two-tray finisher is installed, disconnect it and pull it away from the machine.

1. Unpack the punch unit and remove all tapes and shipping retainers.
2. Open the front door and remove the rear cover [A] (⚙ x 4).
3. Remove the bracket [B] (⚙ x 2) and paper guide [C] (⚙ x 1).

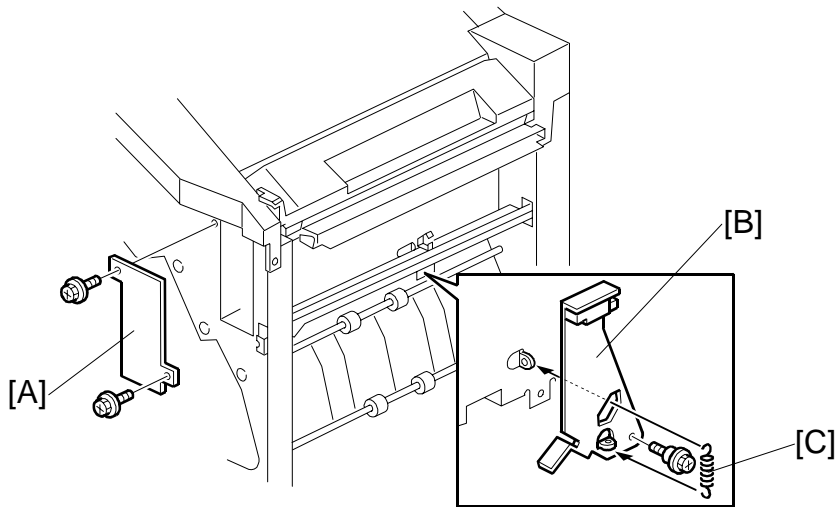

B3771101.WMF

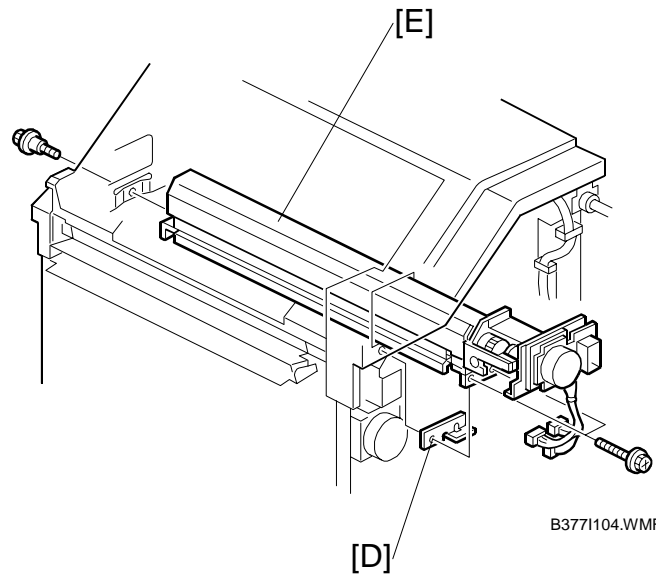

B3771104.WMF

4. Remove the hopper cover [A] (⌀ x 2).
5. Install the sensor bracket [B] (stepped ⌀ x 1).
6. Install the spring [C].
7. Install the 2 mm spacer [D].
8. Install the punch unit [E] (⌀ x 2, stepped ⌀ x 1).

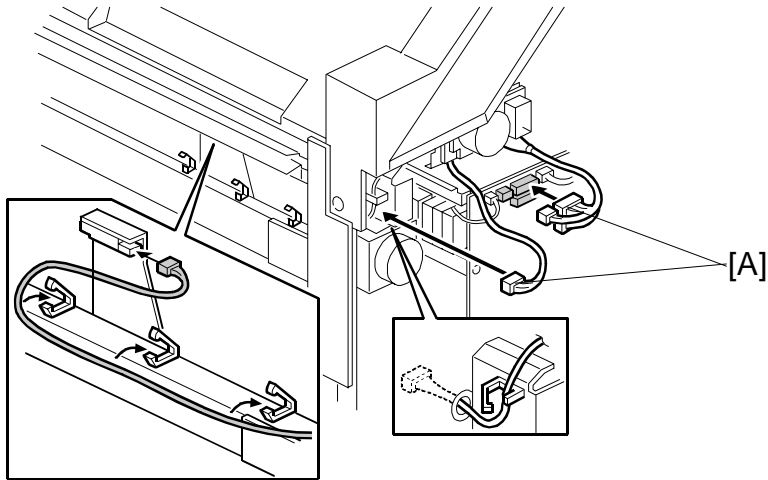

B3771200.WMF

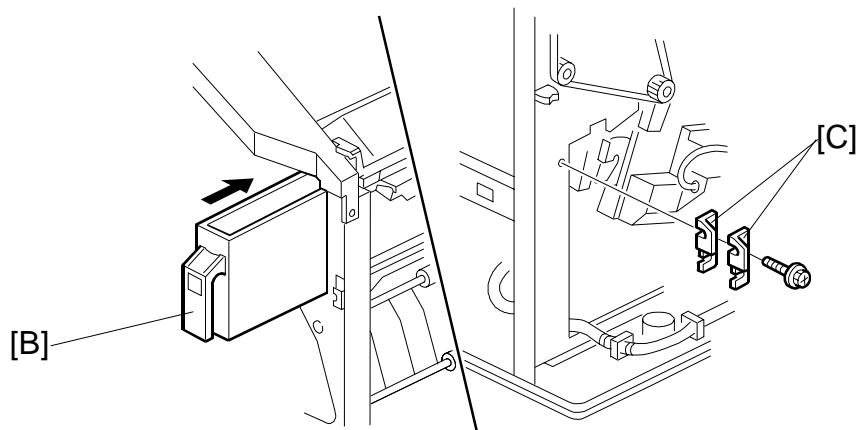

B3771106.WMF

9. Connect the harnesses [A] and clamp them as shown.
10. Slide in the hopper [B].
11. Fasten the two 1 mm spacers [C] to the rear frame for future adjustment.
NOTE: The spacers are used to adjust the horizontal positioning of the punch holes.
12. Reassemble the finisher and check the punch operation.

2. PREVENTIVE MAINTENANCE

2.1 USER MAINTENANCE

The following maintenance kits are available for the customer to do PM.

Type A	Color (C/M/Y) PCU	100KP
Type B	Color (C/M/Y) Development Unit	150KP
Type C	Fusing Unit	100KP
Type D	Black Development Unit / Dust Filter	150KP
Type E	Waste Toner Bottle	50KP
Type F	Black PCU	100KP
Type G	Oil Supply Unit	20KP
Type H	Paper Feed Rollers	150KP

Preventive
Maintenance

Chart: A4(LT)/5%

Mode: 5 prints/job

Environment: Normal temperature and humidity

Yield may change depending on circumstances and print conditions.

When the machine's default settings are used, an error message is displayed when a maintenance counter reaches the value in the PM table below, except for the items in maintenance kit H.

NOTE: To have the machine display the message for maintenance kit H also, set SP5-930-4 to 1.

After the user replaces the items in a maintenance kit, the machine automatically resets the counter for this maintenance kit, except for the items in kit H.

NOTE: Except for the items in kit H, the machine can automatically detect when new items have been installed.

The machine stops when the counters for parts in maintenance kits C, E and G reach the replacement value in the following table.

NOTE: To have the machine display the alert only for maintenance kits C, E, and G, set SP5-930-3 to 0.

Symbol key: C: Clean, R: Replace, L: Lubricate, I: Inspect

Main Unit

Item	20K	50K	100K	150K	EM	Remarks
Black PCU			R			Included in maintenance kit F
Color (Y/M/C) PCU			R			Included in maintenance kit A
Black Development Unit				R		Included in maintenance kit D
Color (C/M/Y) Development Unit				R		Included in maintenance kit B
Fusing Unit			R			Included in maintenance kit C
Oil Supply Unit	R					Included in maintenance kit G
Waste Toner Bottle		R				Included in maintenance kit E
Dust Filter				R		Included in maintenance kit D
Pick-up Roller				R		Included in maintenance kit H
Feed Roller				R		Included in maintenance kit H
Separation Roller				R		Included in maintenance kit H

Punch Kit

Item	10K				EM	Remarks
Chads	I					Discard chads.

2.2 SERVICE MAINTENANCE

NOTE: After replacing the transfer unit, make sure to reset the maintenance counter using SP7-804-16 and 7-804-27.

After replacing paper feed rollers, reset the maintenance counters for these also: By-pass tray (7-804-10), Tray 1 (7-804-11), Tray 2 (7-804-12), Tray 3/LCT (7-804-13), Tray 4 (7-804-14)

Symbol key: C: Clean, R: Replace, L: Lubricate, I: Inspect

Main unit

Item	20K	50K	100K	150K	1,000K	EM	Remarks
Transfer Unit					R		
By-pass Feed Roller				R			
By-pass Pick-up Roller				R			
By-pass Separation Roller				R			

One-tray Paper Feed Unit (500 sheets x 1)

Item	20K	50K	100K	150K	1,000K	EM	Remarks
Relay Roller						C	Damp cloth
Bottom Plate Pad						C	Damp cloth

Two-tray Paper Feed Unit (500 sheets x 2)

Item	20K	50K	100K	150K	1,000K	EM	Remarks
Relay Roller						C	Damp cloth
Bottom Plate Pad						C	Damp cloth

LCT (2000 sheets)

Item	20K	50K	100K	150K	1,000K	EM	Remarks
Relay Roller						C	Damp cloth
Bottom Plate Pad						C	Damp cloth

Two-tray Finisher

Items	20K	50K	100K	150K	1,000K	EM	Remarks
Rollers						C	Damp cloth
Discharge Brush						C	Dry cloth
Sensors						C	Blower brush
Jogger Fences						I	Replace if required.

Four-bin Mailbox

Item	20K	50K	100K	150K	1,000K	EM	Remarks
Rollers						C	Damp cloth
Tray Paper Sensors						C	Blower brush or dry cloth

3. REPLACEMENT AND ADJUSTMENT

⚠ CAUTION
 Turn off the main switch and unplug the machine before beginning any of the procedures in this section.

NOTE: This manual uses the following symbols.

 : See or refer to

 : Screw

 : Connector

 : Clip ring

 : E ring

3.1 SPECIAL TOOLS

Part Number	Part Name	Q'ty
A2309352	Flash Memory Card - 4MB	1
G0219350	Loop-back connector - Parallel	1

Replacement
Adjustment

3.2 IMAGE ADJUSTMENT

3.2.1 REGISTRATION

Leading Edge

Adjusts the leading edge registration for each paper type and process line speed.

Side to Side

Adjusts the side to side registration for each paper feed station.

NOTE: The side to side registration for the optional paper feed unit, LCT, and duplex unit can be adjusted with SP mode or with the user tools (Maintenance menu).

Adjustment Standard

For standard trays, optional paper feed units, LCT and bypass feed table

- Leading edge: 4.2 ± 2 mm
- Side to side: 4.2 ± 2 mm

For duplex unit

- Leading edge: 4.2 ± 4 mm
- Side to side: 4.2 ± 4 mm

Adjustment Procedure

1. Enter SP mode and access SP5-997.
2. Print out the pattern (14: 1-dot trimming pattern) with SP5-997.
3. Perform the leading edge registration adjustment.
 - 1) Check the leading edge registration [A] and adjust it with SP1-001.
 - 2) Select the adjustment conditions (paper type and process line speed).
 - 3) Input the value then press the [Escape] key.
 - 4) Check the leading edge adjustment by generating the trim pattern.
4. Perform the side to side registration adjustment.
 - 1) Check the side to side registration [B] and adjust it with SP1-002.
 - 2) Select the adjustment conditions (paper feed station).
 - 3) Input the value then press the [Escape] key.
 - 4) Check the side to side adjustment by generating the trim pattern.

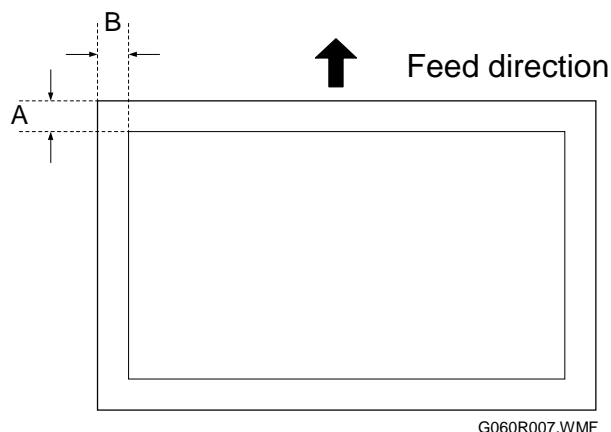

3.2.2 COLOR REGISTRATION

Line Position Adjustment

Normally, the automatic line position adjustment is executed under a specified condition to optimize the color prints. If a color registration shifts such as after moving the printer, execute "Auto Adjust" with the user tools maintenance menu or SP5-993-2 to do the forced line position adjustment.

Adjustment for Line Speed of Fusing Unit

Optimize the line speed for the fusing unit when the color registration shifts more on the trailing edge compared with that on the leading edge, even after line position adjustment is executed. Adjust the speed of development motor-K with the following user tool in the Maintenance menu.

"Menu/Maintenance/Color Regist./Fuser Adjust/Custom Adjust"

Refer to Maintenance Guide 1 of the Operating Instructions for how to adjust this.

3.2.3 PRINTER GAMMA

NOTE: Normally, the printer gamma is enough to adjust the color balance to archive the optimum print output. The gamma correction is only required for fine-tuning to meet the user requirements.

Adjustment Overview

Make the gradation scales on the printout smooth from the highlight to the shadow density. Adjust the CMY gradation scale at the top of the chart by balancing the density of the C, M, and Y gradation scales – the CMY gray scale should change smoothly from minimum to maximum, and there should be no coloration.

For each color, you can adjust 15 points between 0 (lowest density) and 255 (highest density).

The gradation scales marked 'Default Value' are printed according to the default gamma settings. The gamma adjustment changes the densities at the adjustable points in the gradation scale. The gradation scale marked "Current Value" shows the current settings.

During the adjustment procedure, compare the "Current Value" gradation scale with the 'Default Value'. Select the density for each of the 15 adjustable points, excluding points 0 and 255, from the 'Default Value' gradation scale.

The NVRAM holds three printer gamma settings, those saved this time (Current), those saved in the preceding adjustment (Previous), and the factory settings (Factory).

Adjustment Procedure

1. Enter SP mode.
2. Select "1.Service".
3. Select "Data Recall" and load the settings that will serve as the base for the adjustment.
4. Select "Mode Selection", and select the print mode that you are going to adjust.
5. To review the image quality for these settings, choose "Test Page" to print out a color calibration test sheet.
6. Select "Gamma Adj."
7. Adjust the color density at each of the 15 points for a color (CMY and K).
8. When the density setting is complete for all colors, print out a color calibration test sheet again and make sure that the gradation scale for each printed color is smooth and that the CMY gradation scale is gray. Repeat the adjustment if there is an anomaly.
9. If the adjustment results prove satisfactory, execute "Data Save".

3.3 EXTERIOR COVERS

3.3.1 REAR COVER AND UPPER REAR COVER

1. Rear cover [A] (⚙ x 4, 2 hooks)
2. Remove the optional mailbox if it is installed.
3. Upper exit cover [B] (1 hook), if the optional mailbox is not installed.
4. Open the upper right cover [C].
5. Upper rear cover [D] (⚙ x 4)

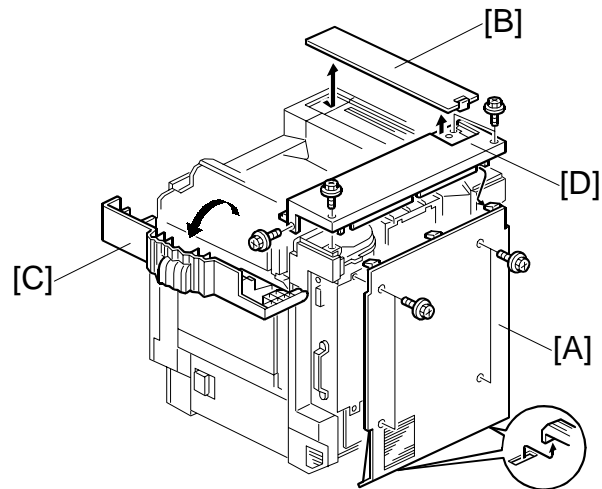

G060R201.WMF

3.3.2 PAPER EXIT TRAY

1. Paper exit tray [A] (⚙ x 2)

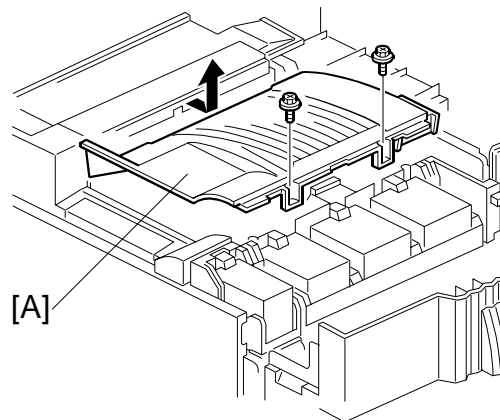

G060R202.WMF

3.3.3 UPPER RIGHT COVER

1. Right cover [A] (⚙ x 2)
NOTE: To loosen the screws, close the upper right cover; to remove the right cover, open the upper right cover.
2. Upper right cover [B]

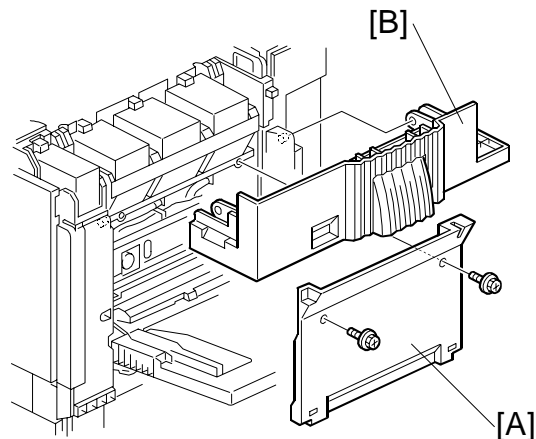

G060R204.WMF

3.3.4 FRONT COVER

1. Front cover [A] (2 pins)

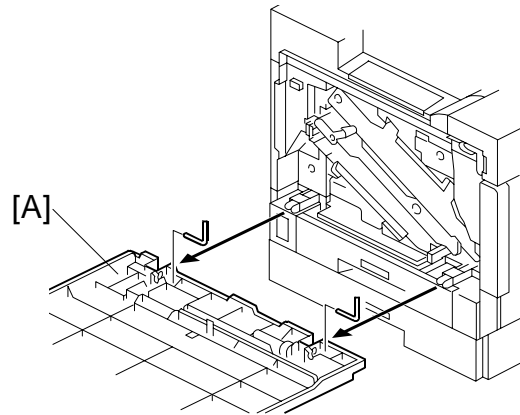

G060R410.WMF

3.3.5 LEFT COVER AND REAR LEFT COVER

1. Remove the optional finisher from the printer if it is installed.
2. Remove the optional duplex inverter unit if it is installed.
3. Connector cover [A], if the optional duplex unit is not installed
4. Left cover [B] (⌘ x 6)

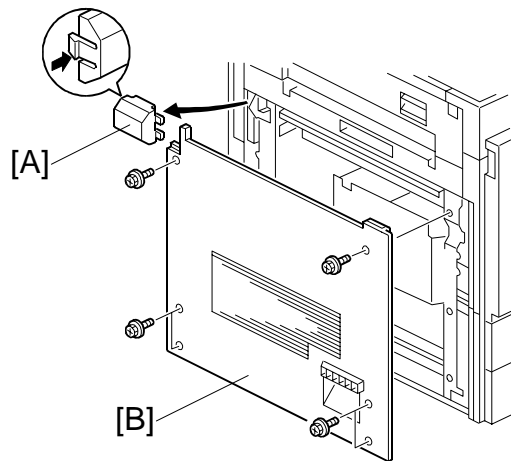

G060R714.WMF

5. Open the left door [C].
6. Rear left cover [D] (⌘ x 3)

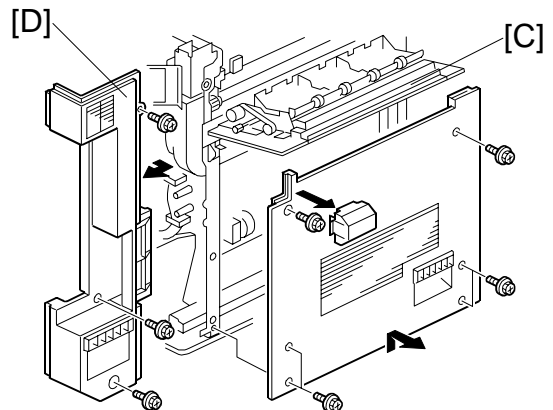

G060R717.WMF

3.3.6 UPPER LEFT COVER AND OPERATION PANEL

1. Open the front cover.
2. Open the upper light cover
3. Operation panel [A] (⚙ x 2, 📐 x 2, 2 hooks)
4. Upper left cover [B] (⚙ x 2, 1 hook)

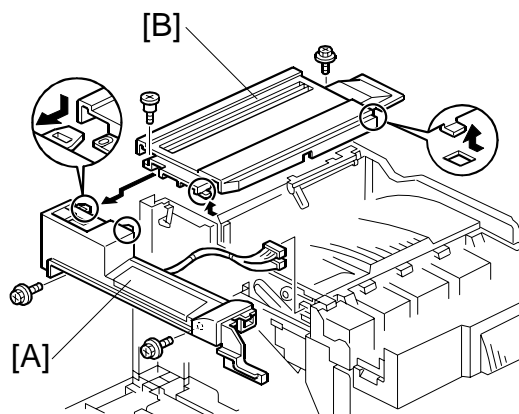

G060R716.WMF

Replacement
Adjustment

3.4 LASER OPTICS

⚠ WARNING
Turn off the main switch and unplug the machine before beginning any of the procedures in this section. Laser beams can cause serious eye injury.

3.4.1 CAUTION DECAL LOCATIONS

Caution decals are placed as shown below.

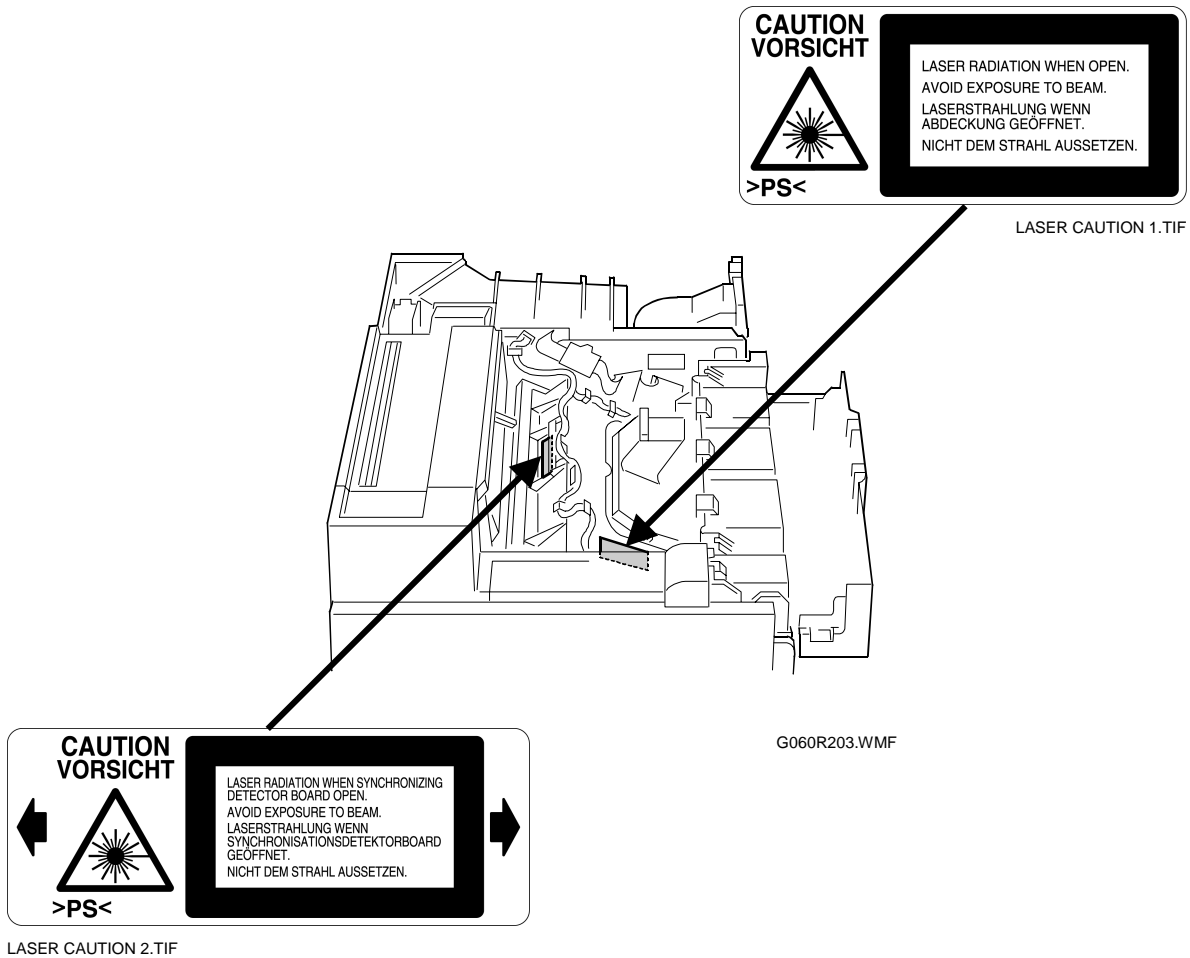

⚠ WARNING
Be sure to turn off the main switch and disconnect the power plug from the power outlet before beginning any disassembly or adjustment of the laser unit. This printer uses a class IIIb laser beam with a wavelength of 655 nm and an output of 7 mW. The laser can cause serious eye injury.

3.4.2 LASER OPTICS HOUSING UNIT

1. Rear cover (☛ 3.3 EXTERIOR COVERS)
2. Upper rear cover (☛ 3.3 EXTERIOR COVERS)
3. Paper exit tray (☛ 3.3 EXTERIOR COVERS)
4. Right cover (☛ 3.3 EXTERIOR COVERS)
5. Securing screws for the toner supply unit [A] (🔩 x 4)

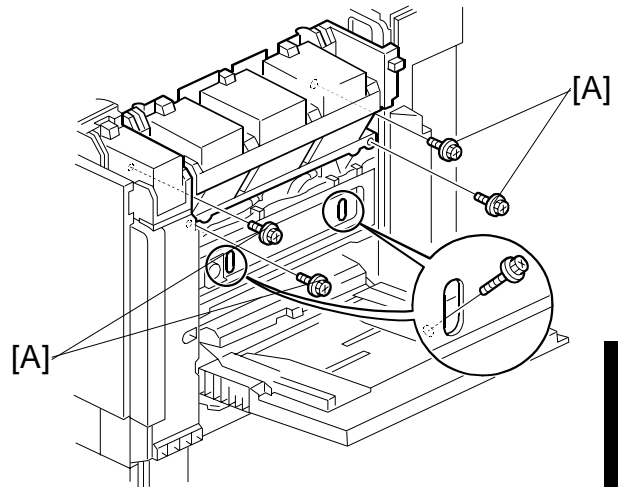

G060R205.WMF

Replacement Adjustment

6. Hold the toner supply unit [B] up ①. Then, lower the unit ②.
- NOTE:** The pin [C] for the front and rear shafts holds the toner supply unit.

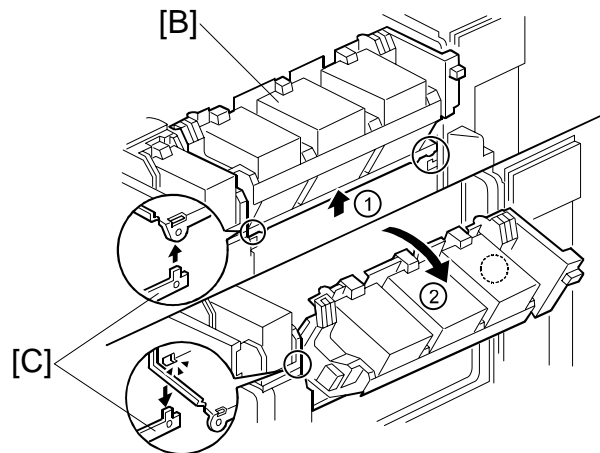

G060R206.WMF

7. Connector cover [D] (🔩 x 1)
8. Four flat cables [E]
9. Connector [F]

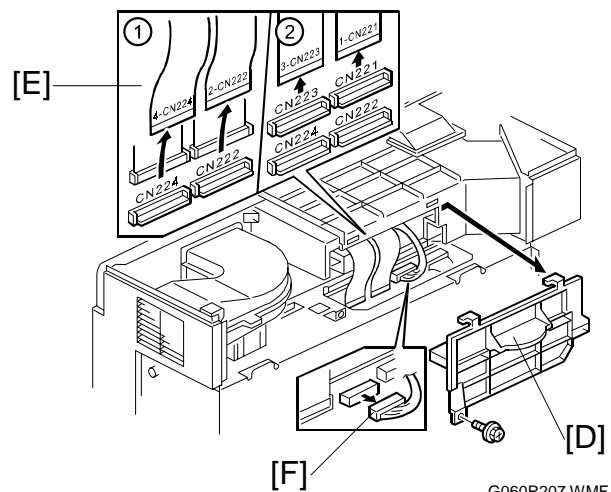

G060R207.WMF

10. Flat cable bracket [G] (🔩 x 1)

11. Cable (clamps [H])

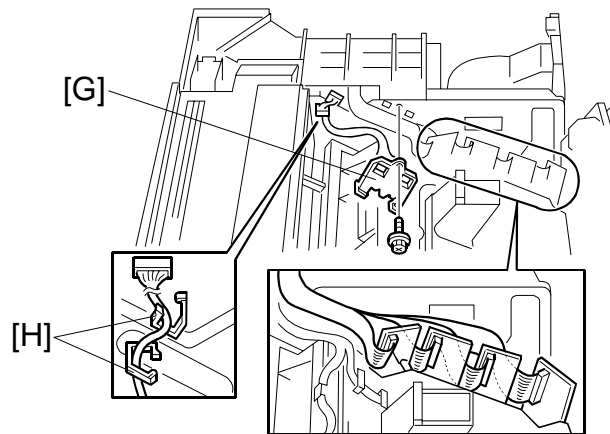

G060R208.WMF

12. Duct [I]

13. Laser optics housing unit (🔩 x 2)

NOTE: Hold the unit with both hands and slowly lift up.

14. After reinstalling the laser optics housing unit, do some adjustments (👁️ the procedures on the following page).

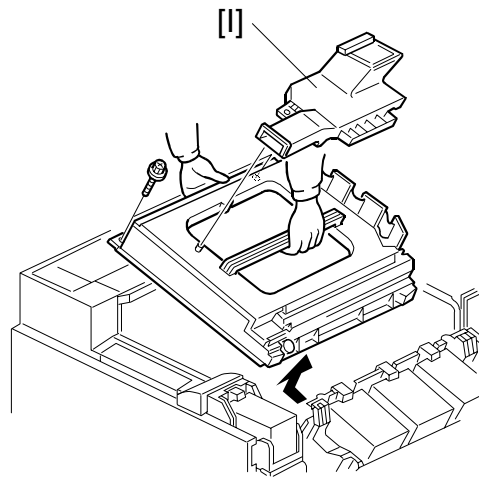

G060R209.WMF

Adjustments after Replacing the Laser Optics Housing Unit

1. Enter SP mode.
2. Input the values printed on three decals on the new laser optics housing unit into the following SPs. Each decal contains two values.

	Value on the left	Value on the right	Function
Decal 1	SP2-109-3	SP2-109-2	Laser beam pitch
Decal 2	SP2-994-4	SP2-994-3	Main-scan registration correction for black and cyan
Decal 3	SP2-994-2	SP2-994-1	Main-scan registration correction for magenta and yellow

Decal 1

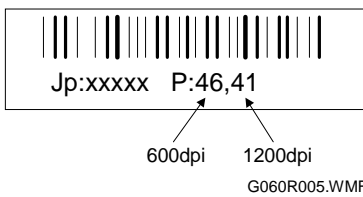

Decal 2

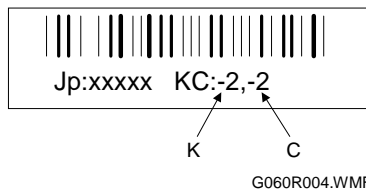

Decal 3

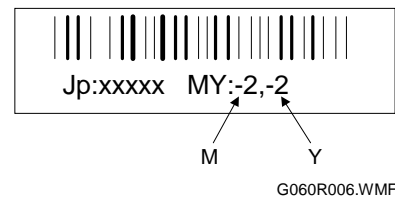

Replacement Adjustment

3. Print out the following test pattern (17: cross-stitch main-scan) with SP5-997.
4. Check these test patterns. If the laser beam pitch is not correct, vertical black strips seem to appear.
 - Cross-stitch pattern: The thin lines should be of uniform thickness (no striping effect should appear on the printout).
5. Adjust the laser beam pitch values in SP2-109-2 and -3 until the printout is correct, as shown below.

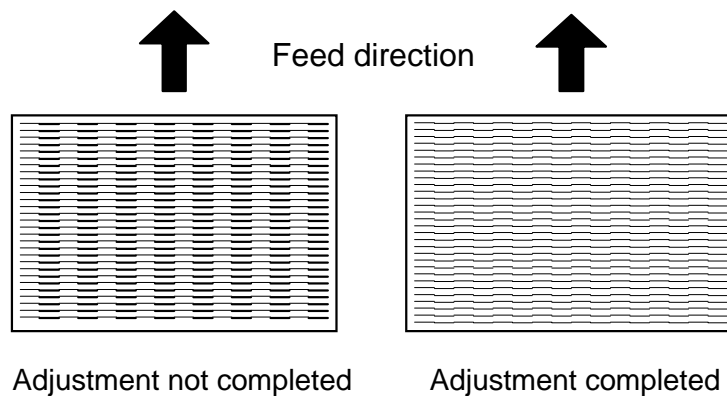

G060R002.WMF

6. Execute SP5-993-2 or "Auto Adjust" with the Maintenance menu in the user tools.

3.4.3 POLYGON MIRROR MOTOR

1. Laser optics housing unit (☛ 3.4.2 LASER OPTICS HOUSING UNIT)
2. Cover [A] (🔩 x 4)
3. Polygon mirror motor [B] (🔩 x 4 and 📏 x 1)

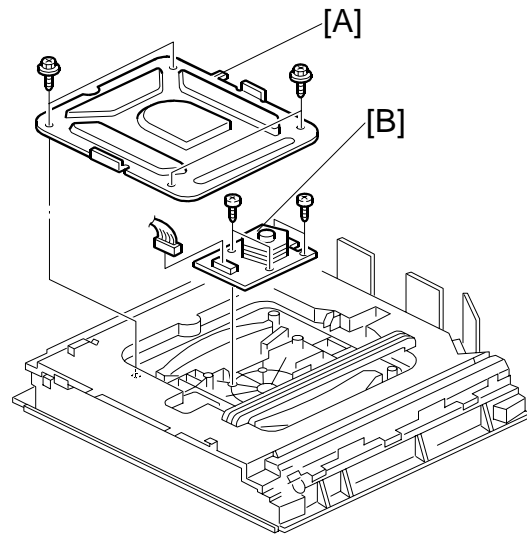

G060R210.WMF

3.4.4 LASER SYNCHRONIZING DETECTOR BOARDS

1. Laser optics housing unit (☛ 3.4.2 LASER OPTICS HOUSING UNIT)
2. Synchronizing detector boards [A] (🔩 x 1, 📏 x 2)

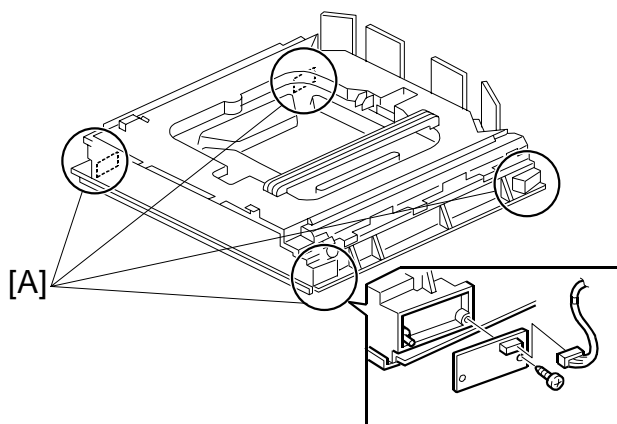

G060R211.WMF

3.5 PCU AND DEVELOPMENT UNIT

NOTE: Do not touch the PCU development drum. Do not let any metal object touch the PCU development sleeve.

1. Open the front cover [A].
2. To raise the drum positioning plate [B], loosen the 2 screws.
3. Turn the release lever [C] counter-clockwise.

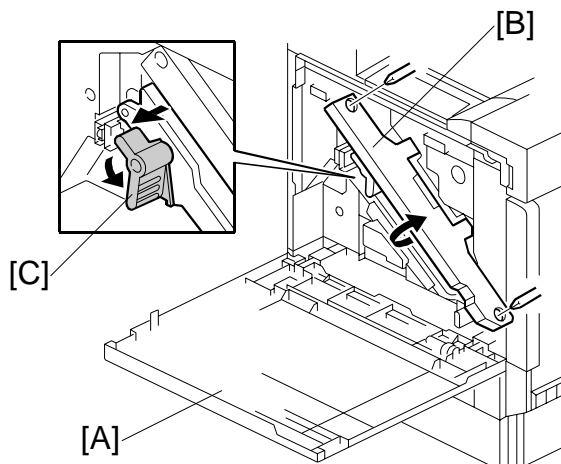

G060R301.WMF

Replacement
Adjustment

4. Pull the required development unit [D] out.
5. Install a new development unit.
6. Check that the development units are installed in the proper color order (black → yellow → cyan → magenta moving from left to right).

NOTE: When the main switch is turned on, the newly installed development units are automatically initialized.

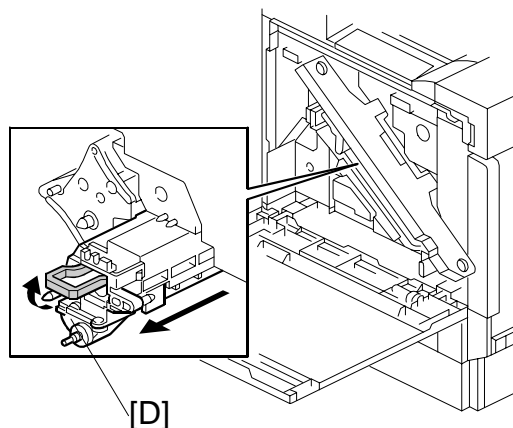

G060R302.WMF

7. Release the lever and pull the PCU [E] out until the handle appears.
8. Grasp the handle [F] and pull the PCU out of the machine.

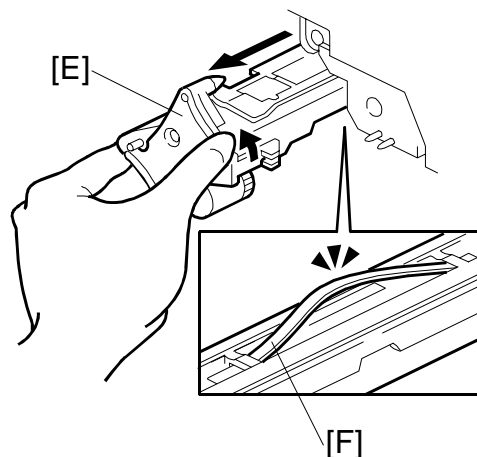

G060R303.WMF

3.6 PAPER FEED

3.6.1 PICK-UP, FEED, AND SEPARATION ROLLERS

Tray 1 and Tray 2

1. Tray 1 and Tray 2
2. Pick-up roller [A] (1 hook)
3. Feed roller [B] (⌀ x 1)
4. Separation roller [C] (⌀ x 1)

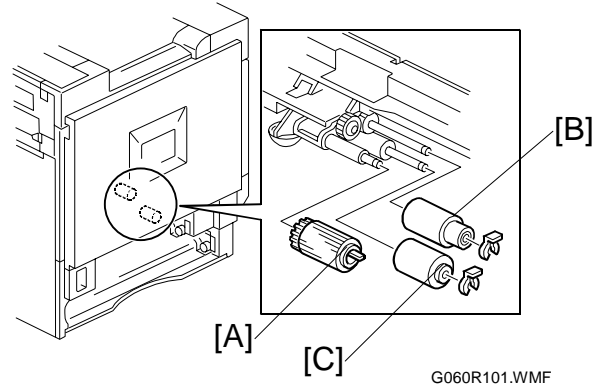

By-pass Tray

1. Open the right door.
2. By-pass tray cover [A] (1 hook, ⌀ x 1)
3. Raise the paper end sensor actuator.
4. Pick-up roller [B] (1 hook)

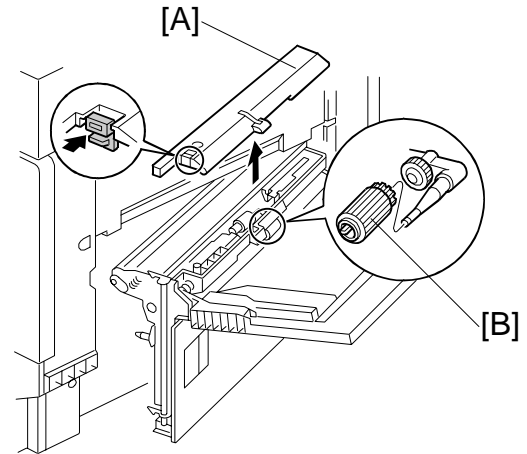

5. Feed roller [C] (⌀ x 1)
6. Separation roller [D] (⌀ x 1)

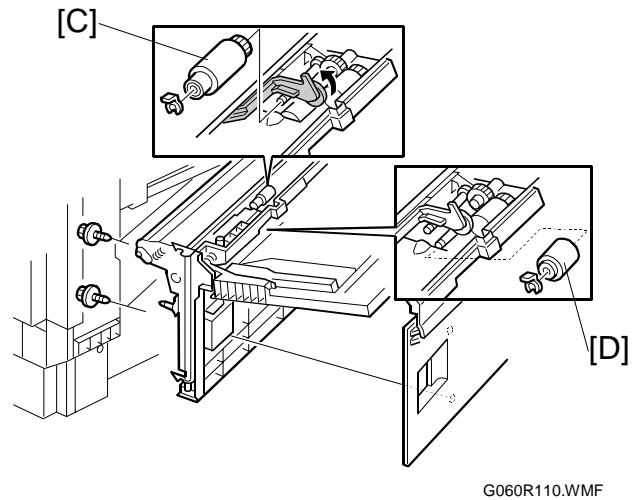

3.6.2 PAPER WIDTH DETECTION BOARD

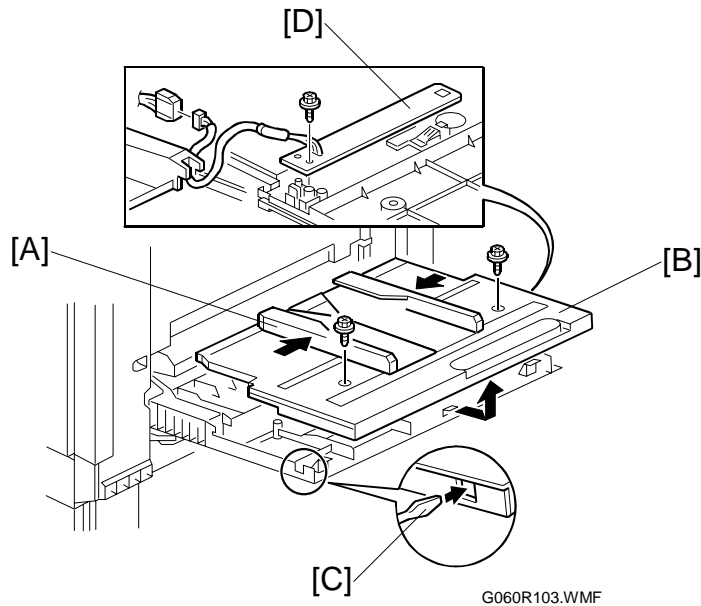

Replacement
Adjustment

1. Open the by-pass tray.
2. Center the side fences [A].
3. By-pass tray cover [B] (⚙ x 2, 2 hooks)
4. There is a square hole [C] on each side of the tray. Insert a screwdriver into each of the holes.
5. Paper width detection board [D] (⚙ x 1, 📏 x 1)

3.6.3 VERTICAL TRANSPORT SENSOR

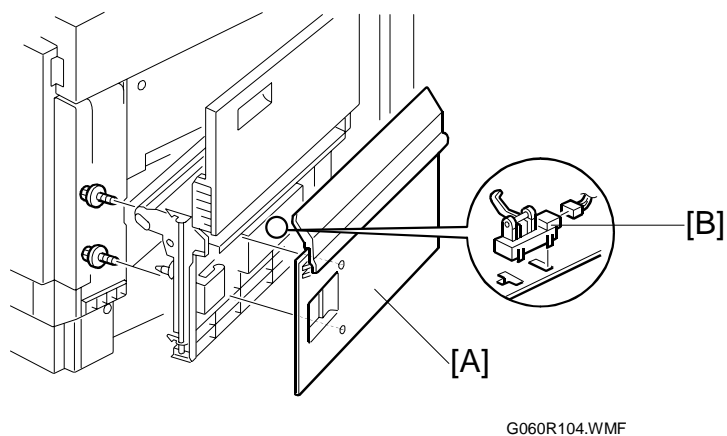

1. Open the right door.
2. Vertical transport cover [A] (⚙ x 4)
3. Vertical transport sensor [B] (📏 x 1)

3.6.4 RIGHT DOOR UNIT

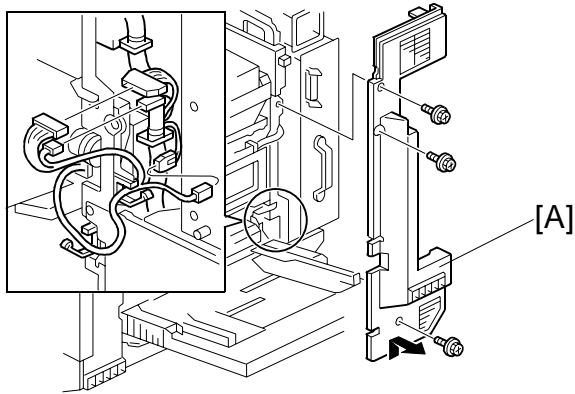

G060R105.WMF

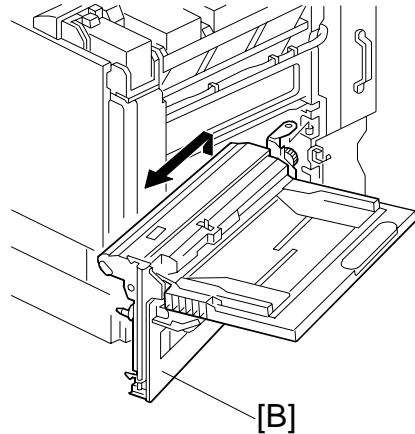

G060R106.WMF

1. Rear cover (☛ 3.3 EXTERIOR COVERS)
2. Upper rear cover (☛ 3.3 EXTERIOR COVERS)
3. Upper right cover (☛ 3.3 EXTERIOR COVERS)
4. Right rear cover [A] (🔩 x 4)
5. Open the right door.
6. Lift the vertical transport unit [B] to remove it from its hinges (🔩 x 3).

3.6.5 REGISTRATION SENSOR AND RELAY SENSOR

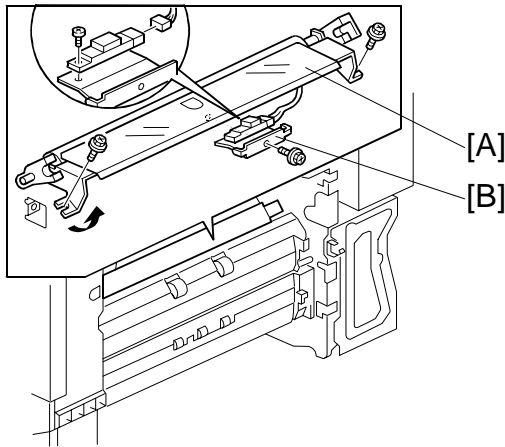

G060R108.WMF

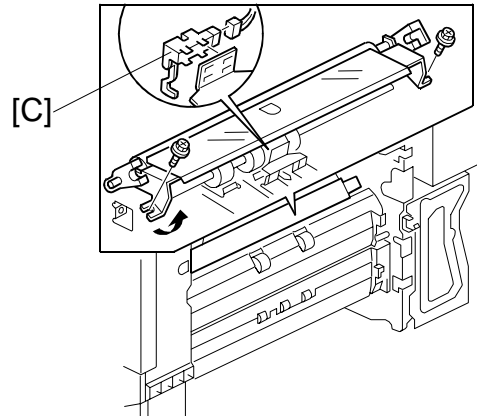

G060R109.WMF

Replacement
Adjustment

1. Right door unit (☛ 3.6.4 RIGHT DOOR UNIT)
2. Registration guide [A] (🔩 x 2)
3. Registration sensor [B] (🔩 x 2, 📏 x 1)
4. Relay sensor [C] (📏 x 1)

3.6.6 PAPER FEED CLUTCHES

1. Paper Trays
2. Rear cover (☛ 3.3 EXTERIOR COVERS)
3. Swing out the high voltage supply unit (☛ 3.9.2 MOVING THE HIGH VOLTAGE SUPPLY UNIT - C, B OUT OF THE WAY).
4. Clutch holder [A] (🔩 x 2, 1 bearing)
5. Paper feed clutch for tray 1 [B] (📏 x 1)
6. Clutch holder [C] (🔩 x 2, 1 bearing)
7. Paper feed clutch for tray 2 [D] (📏 x 1)

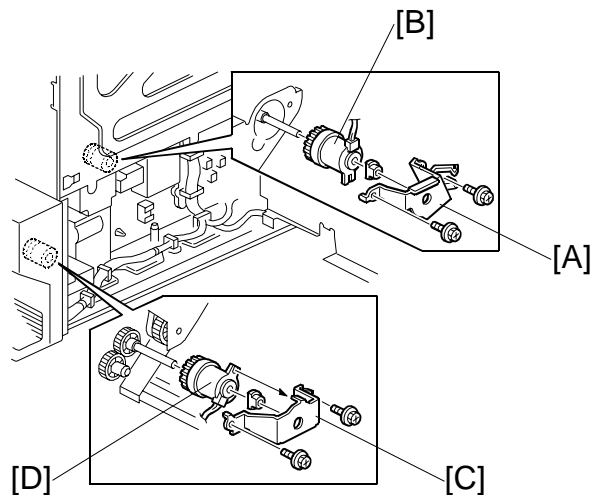

G060R713.WMF

3.6.7 BY-PASS FEED CLUTCH

1. Right door unit (☛ 3.6.4 RIGHT DOOR UNIT)
2. By-pass tray cover [A] (⚙ x 1, 1 hook)
3. Loosen the screw on the right door latch.
4. Turn the latch the opposite direction.
5. Upper guide plate [B] (⚙ x 4)
6. Support plate [C] (Ⓒ x 2)
7. Relay gear [D] (1 hook)
8. By-pass feed clutch [E] (⚙ x 1)

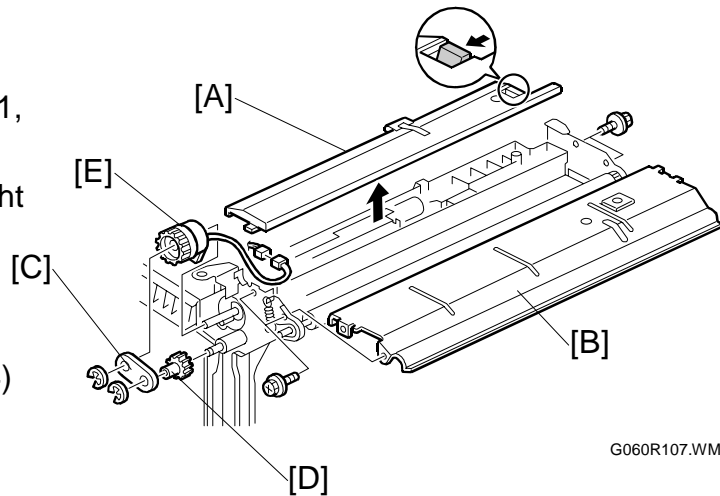

G060R107.WMF

3.6.8 TRAY LIFT MOTOR

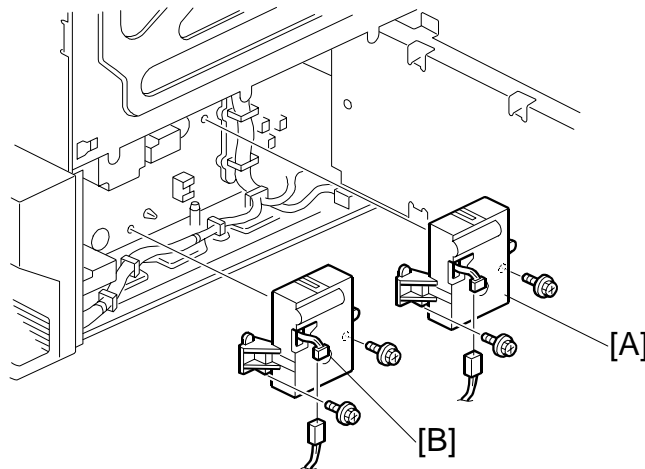

G060R712.WMF

1. Rear cover (☛ 3.3 EXTERIOR COVERS)
2. Swing out the high voltage supply unit. (☛ 3.9.2 MOVING THE HIGH VOLTAGE SUPPLY UNIT - C, B OUT OF THE WAY)
3. Tray lift motors (tray 1 [A], tray 2 [B]) (⚙ x 2, ⚙ x 1)

3.7 TRANSFER AND PAPER TRANSPORT UNIT

3.7.1 TRANSFER UNIT

NOTE: When removing or installing the transfer unit, grasp the central areas of the front and rear frame. Do not touch the transfer belt [C]. Do not damage the entrance mylar [D].

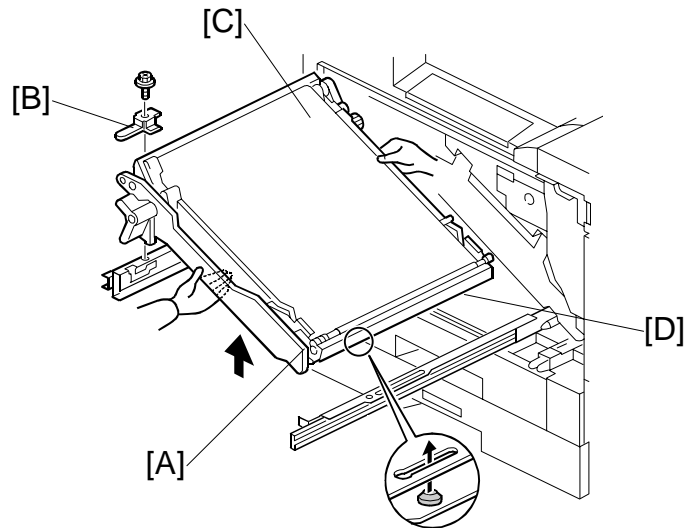

G060R404.WMF

Replacement
Adjustment

1. Turn the release lever counterclockwise. (☛ 3.5 PCU AND DEVELOPMENT UNIT)
2. Pull out the transfer unit [A] until the entire unit is visible.
3. Bracket [B]
4. Grasp the transfer unit as shown above. Lift the unit to remove it.

After replacing the transfer unit, execute SP3-920-5 (refresh mode).

3.7.2 TRANSFER BELT CLEANING UNIT

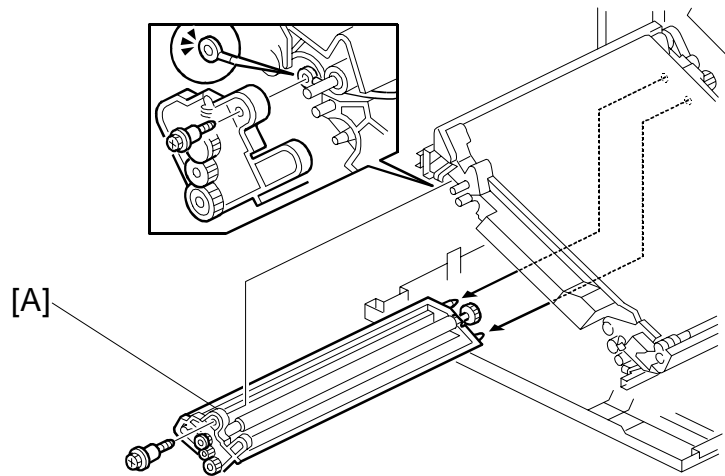

G060R402.WMF

1. Turn the lever counterclockwise (☛ 3.5 PCU AND DEVELOPMENT UNIT).
2. Pull out the transfer unit until the entire unit is visible.
3. Transfer cleaning unit [A] (☛ x 1, 3 pins).

After replacing the transfer belt cleaning unit, execute SP3-920-5 (refresh mode).

3.7.3 CLEANING BLADE AND CLEANING ROLLER

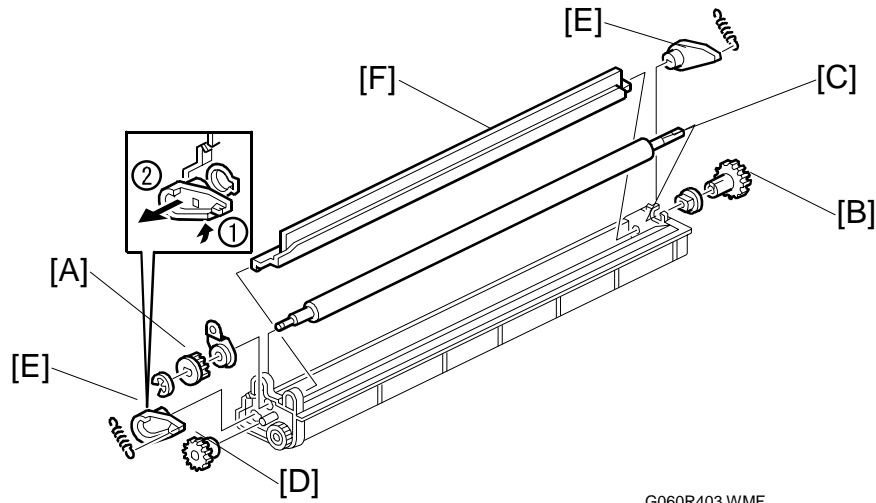

1. Front gear [A] (⊕ x1, 1 bearing)
2. Rear gear [B] (1 hook, 1 bearing)
3. Cleaning bias roller [C]
4. Drive gear [D]
5. Cams [E] (1 spring)
6. Cleaning blade [F] (1 bearing)

After replacing the cleaning blade, execute SP3-920-5 (refresh mode).

3.7.4 TRANSFER BELT

NOTE: Do not touch the transfer belt during handling. When replacing the belt, hold the belt at its end.

1. Transfer unit (☛ 3.7.1 TRANSFER UNIT)
2. Transfer cleaning unit (☛ 3.7.2 TRANSFER BELT CLEANING UNIT)
3. High voltage wire [A] (🔩 x 1, 📌 x 1)
4. Transfer entrance guide [B] (🔩 x 2)
5. Right bracket [C] (🔩 x 2, 1 ground wire holder)

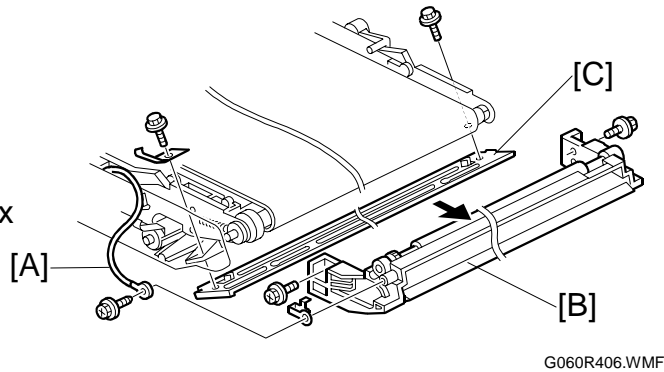

6. Unhook the gear [D] (1 bushing)
7. Belt-holder plate [E] (Ⓢ x 1, 1 spring [F], 1 bushing)

CAUTION: Be careful that the spring does not jump out when removing or reinstalling.

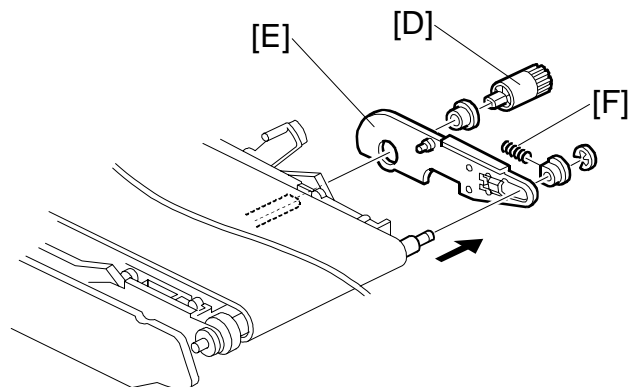

8. Transfer exit unit [G] (⚙ x 1, 1 step screw)
9. Left bracket [H] (⚙ x 2, ⚙ x 1, 1 ground wire holder)

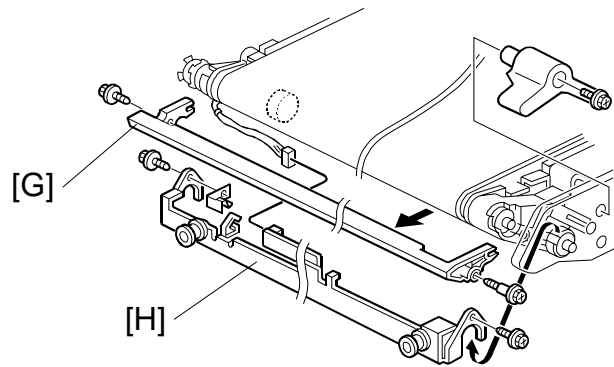

G060R408.WMF

Replacement
Adjustment

10. Lay the transfer unit on its side. Grasp the upper end of the transfer belt and pull the transfer belt [I] up and out.
11. When reinstalling the belt, check that the end with the belt-lot number comes to the rear side of the machine.

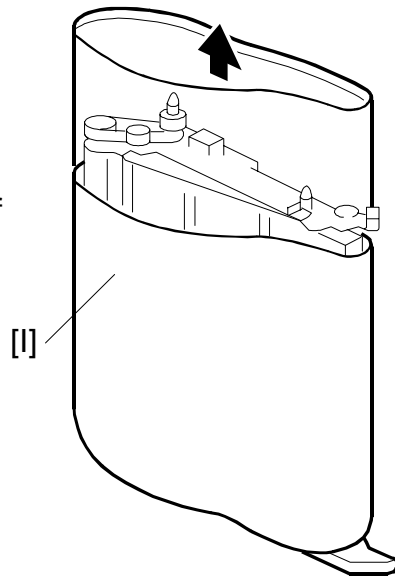

G060R409.WMF

After replacing the transfer belt, execute SP3-920-5 (refresh mode).

3.8 FUSING

⚠ CAUTION

1. Be careful when handling the fusing unit. It is very hot.
2. Take care not to spill silicone oil.

3.8.1 FUSING UNIT

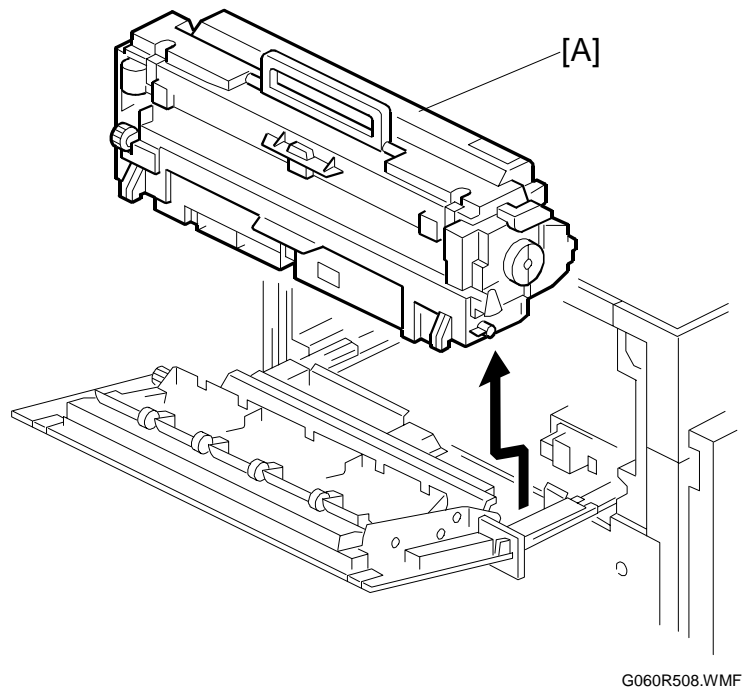

1. Detach the finisher from the printer if it is installed.
2. Open the duplex inverter unit if it is installed.
3. Fusing unit [A]

After replacing the fusing unit, optimize the line speed for fusing unit by adjusting the speed of development motor-K with the Maintenance menu in the user tools "Menu/Maintenance/Color Regist./Fuser Adjust/At Unit Replace".

This mode is automatically required after the machine detects a new fusing unit is installed. Refer to Maintenance Guide 1 of the Operating Instructions for how to adjust this.

3.8.2 OIL SUPPLY UNIT

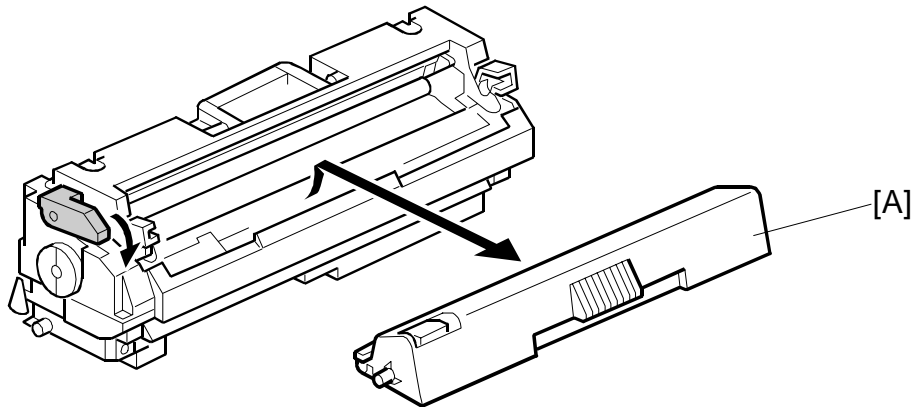

G060R509.WMF

1. Detach the finisher from the printer if it is installed.
2. Open the duplex inverter unit if it is installed.
3. Fusing unit (☛ 3.8.1 FUSING UNIT)
4. Oil supply Unit [A]

Replacement
Adjustment

3.8.3 PAPER EXIT

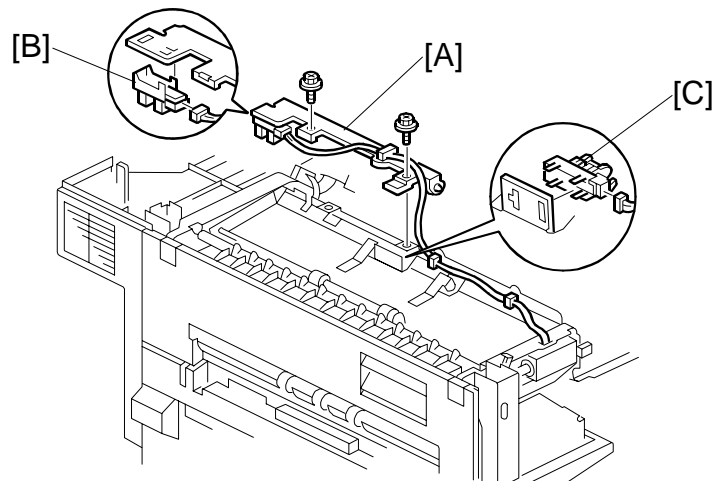

G060R601.WMF

1. Paper exit cover (☛ 3.3 EXTERIOR COVERS)
2. Exit upper limit sensor cover [A] (🔩 x 2)
3. Exit upper limit sensor [B]
4. Paper exit sensor [C]

3.9 ELECTRICAL COMPONENTS

3.9.1 MOVING THE CONTROLLER BOX OUT OF THE WAY

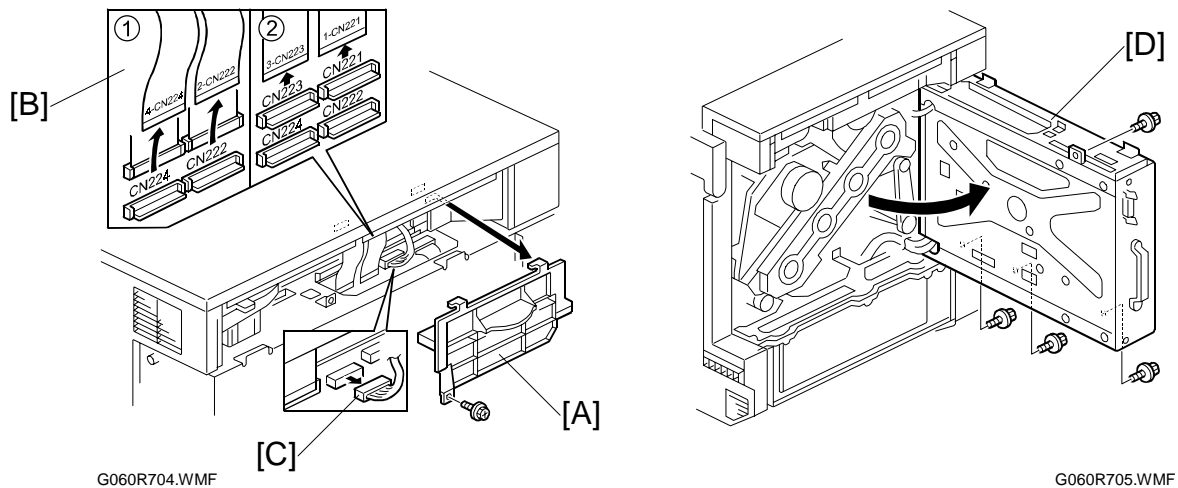

G060R704.WMF

G060R705.WMF

1. Rear cover (☛ 3.3 EXTERIOR COVERS)
2. Connector cover [A] (🔩 x 1)
3. Four flat cables [B]
4. Connector [C]
5. Swing out the controller box [D] (🔩 x 4).

NOTE: When the controller box is swung out, free-run tests can still be done. However, because the LD cables are disconnected, no output appears.

3.9.2 MOVING THE HIGH VOLTAGE SUPPLY UNIT - C, B OUT OF THE WAY

1. Rear cover (☛ 3.3 EXTERIOR COVERS)
2. Swing out the high voltage supply unit [A] (🔩 x 2).

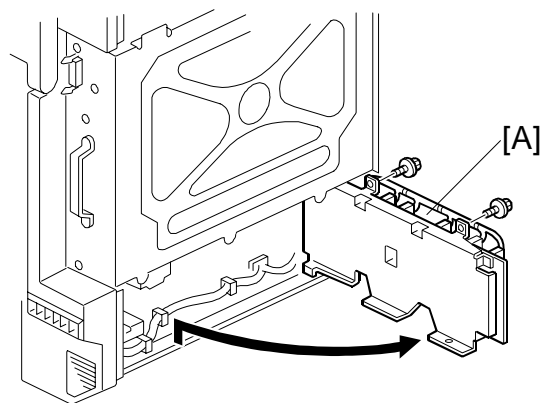

G060R711.WMF

3.9.3 CONTROLLER AND BCU

NOTE: After replacing the BCU or controller, remove the NVRAM on the old board and install it on the new board.

1. Controller [A] (⚙️ x 2)
2. Option bracket [B] (⚙️ x 2)
3. Rear cover [C] (➡️ 3.3 EXTERIOR COVERS)

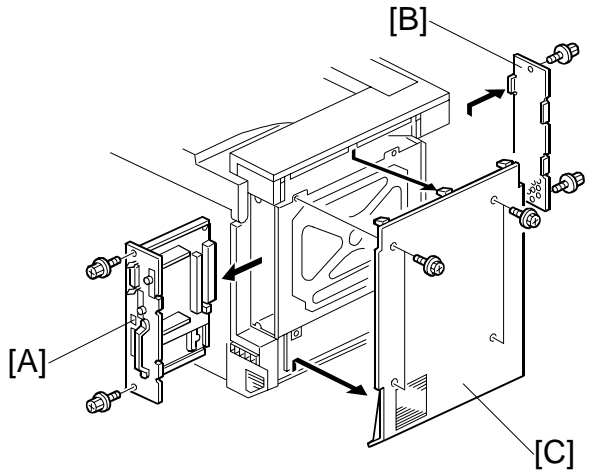

G060R701.WMF

4. Cover bracket [D] (⚙️ x 3)
5. Inner bracket [E] (⚙️ x 2)

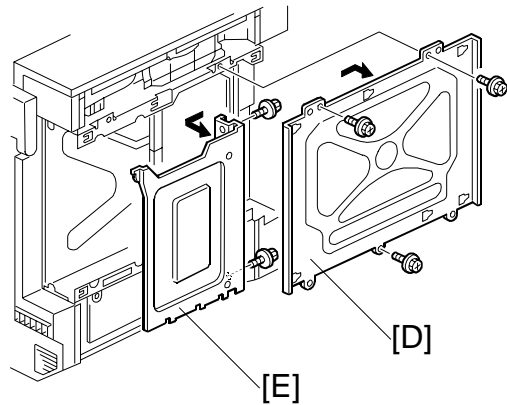

G060R702.WMF

6. Connector cover [F] (⚙️ x 1)
7. BCU [G] (⚙️ x 8, 📡 x 23)

NOTE: After replacing the BCU or controller, remove the NVRAM on the old board and install it on the new board. If the NVRAM on the old board is defective, replace the NVRAM (➡️ 3.9.4 NVRAM REPLACEMENT PROCEDURE).

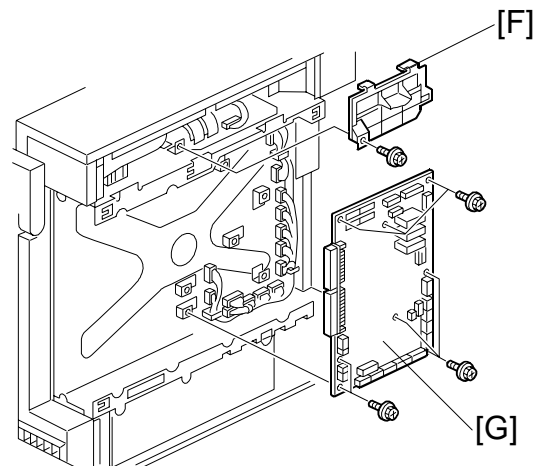

G060R703.WMF

3.9.4 NVRAM REPLACEMENT PROCEDURE

Make sure you have the SMC report (factory settings) that comes with the printer before beginning the following procedure.

NVRAM for BCU

1. Enter SP mode and print out the SMC reports with SP5-990 if possible.
2. Turn off the main switch and unplug the power cord.
3. Replace the NVRAM on the BCU and reassemble the machine.
4. Execute the RAM clear for engine settings with SP5-801-2.
5. Contact your supervisor to enter the machine's device number.
6. Reset the settings for meter charge with SP5-930-1 to -5.
7. Enter the SP mode changes at the factory and the field.

NVRAM for Controller

1. Enter SP mode and print out the SMC reports with SP5-990 if possible.
2. Turn off the main switch and unplug the power cord.
3. Replace the NVRAM on the controller and reassemble the machine.
4. Execute the RAM clear for controller settings and counters with SP5-801-3, -8, -11, and SP7-808-1.
5. Enter the SP mode changes at the factory and the field.

NVRAMs for both BCU and Controller

1. Enter SP mode and print out the SMC reports with SP5-990 if possible.
2. Turn off the main switch and unplug the power cord.
3. Replace the NVRAM on the BCU and the controller, and reassemble the machine.
4. Execute the RAM clear with SP5-801-1 and SP7-808-1.
5. Contact your supervisor to enter the machine's device number.
6. Reset the settings for meter charge with SP5-930-1 to -5.
7. Enter the SP mode changes at the factory and the field.



3.9.5 REMOVING THE HIGH VOLTAGE SUPPLY BOARD - C, B

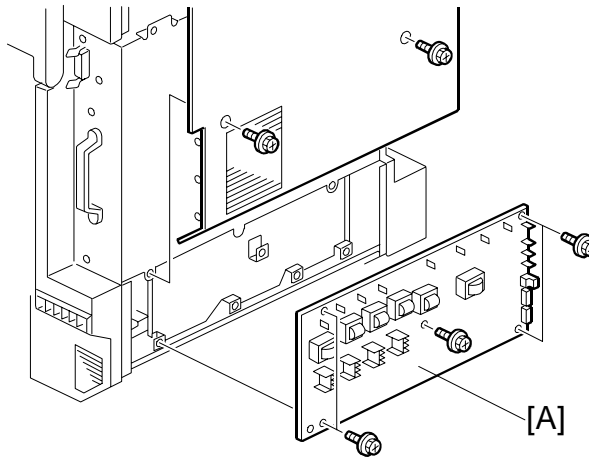

G060R710.WMF

1. Rear cover (☛ 3.3 EXTERIOR COVERS)
2. High voltage supply board [A] (⚙ x 6, 🔌 x 16)

Replacement
Adjustment

3.9.6 PSU

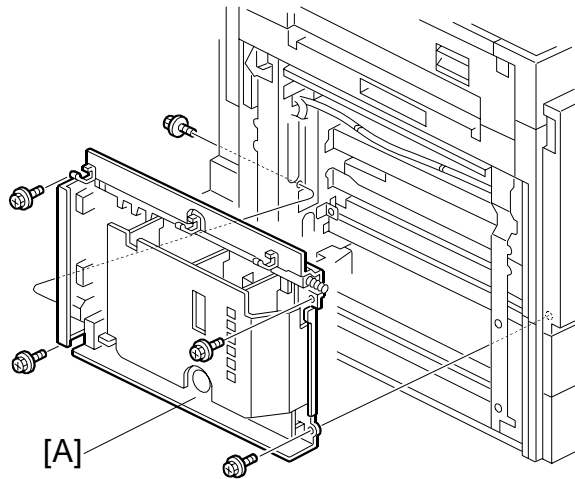

G060R715.WMF

1. Left cover (☛ 3.3 EXTERIOR COVERS)
 2. PSU [A] (⚙ x 5, 🔌 x 12)
- NOTE:** Check that the interlock switches on the PSU work normally after reinstalling the PSU (open/close the left and front doors).

3.10 DRIVE UNIT

3.10.1 REGISTRATION CLUTCH

1. Rear cover (☛ 3.3 EXTERIOR COVERS)
2. Swing out the controller box (☛ 3.3.1 Controller Box).
3. Registration clutch [A] (⚙️ x 1, ⚙️ x 1)

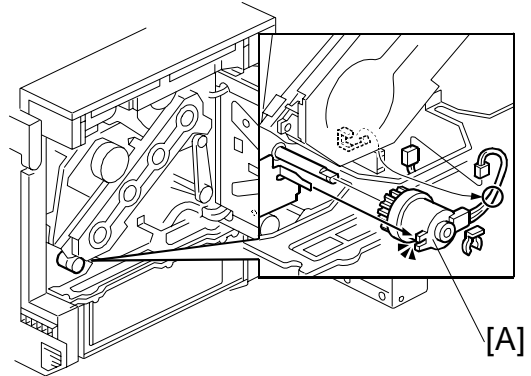

G060R706.WMF

3.10.2 DEVELOPMENT CLUTCHES

1. Rear cover (☛ 3.3 EXTERIOR COVERS)
2. Swing out the controller box (☛ 3.3.1 Controller Box).
3. Drum motor plate [A] (⚙️ x 5)
4. CMYK drum gear [B] (⚙️ x 4)
5. Drive gear [C]
6. Timing belt [D]
7. Drive gear [E]

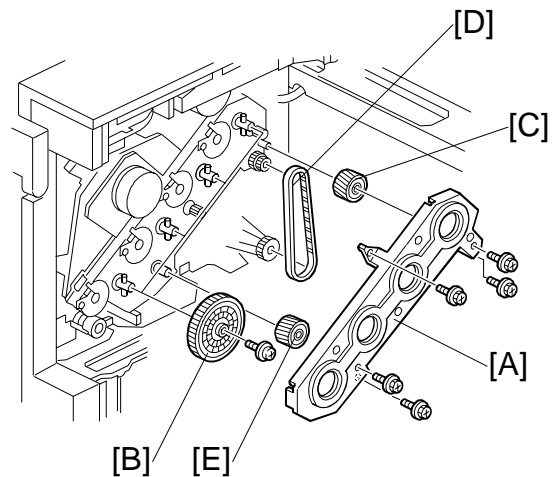

G060R707.WMF

8. Color development clutch securing plate [F] (⚙️ x 8, ⚙️ x 4)
9. Development clutch - K [G]
10. Development clutch - Y [H]
11. Development clutch - C [I]
12. Development clutch - M [J]

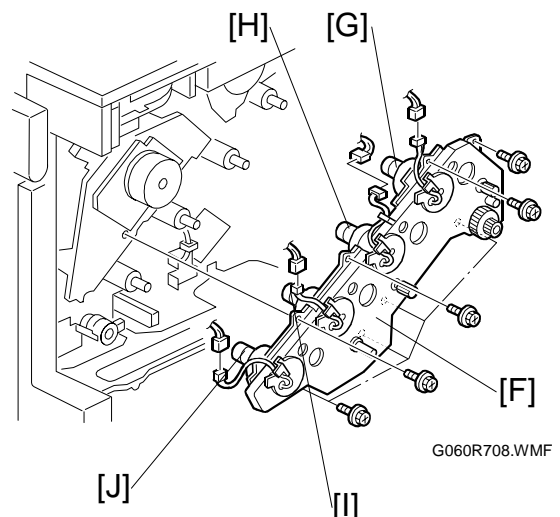

G060R708.WMF

3.10.3 DEVELOPMENT DRIVE MOTOR - CMY

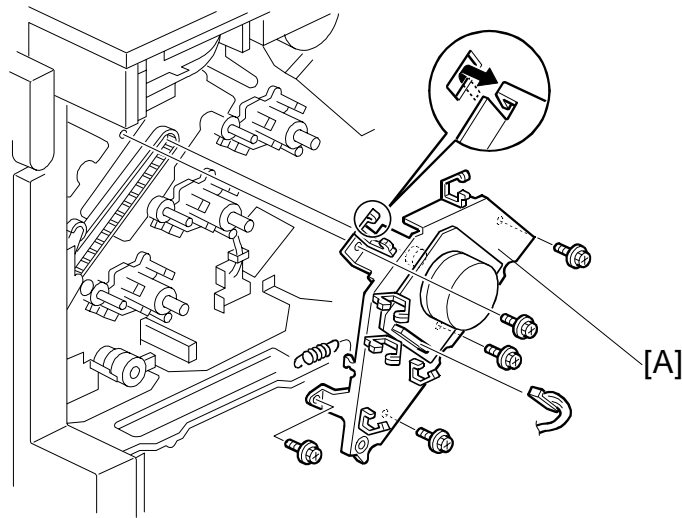

G060R709.WMF

1. Rear cover (☛ 3.3 EXTERIOR COVERS)
2. Color development clutch securing plate (☛ 3.10.2 DEVELOPMENT CLUTCHES)
3. Development drive motor - CMY [A] (⚙ x 5, ⚙ x 3, 1 spring)

Replacement Adjustment

3.10.4 DRUM DRIVE MOTOR - CMY AND DRUM DRIVE MOTOR - K

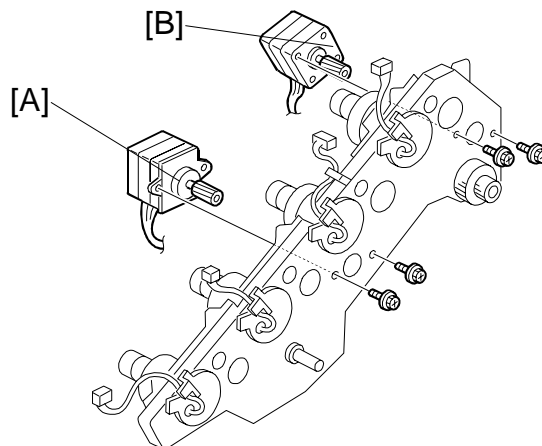

G060R725.WMF

1. Rear cover (☛ 3.3 EXTERIOR COVERS)
2. Color development clutch securing plate (☛ 3.10.2 DEVELOPMENT CLUTCHES)
3. Drum drive motor - CMY [A] (⚙ x 2, ⚙ x 1)
4. Drum drive motor - K [B] (⚙ x 2, ⚙ x 1)

3.10.5 DEVELOPMENT DRIVE MOTOR - K

1. Rear cover (☛ 3.3 EXTERIOR COVERS)
2. Upper rear cover (☛ 3.3 EXTERIOR COVERS)
3. Development clutch-CMYK (☛ 3.10.2 DEVELOPMENT CLUTCHES)
4. Fusing fan duct [A] (🔩 x 1, 📏 x 1)
5. Right duct [B] (🔩 x 1)
6. Upper duct [C] (🔩 x 2)

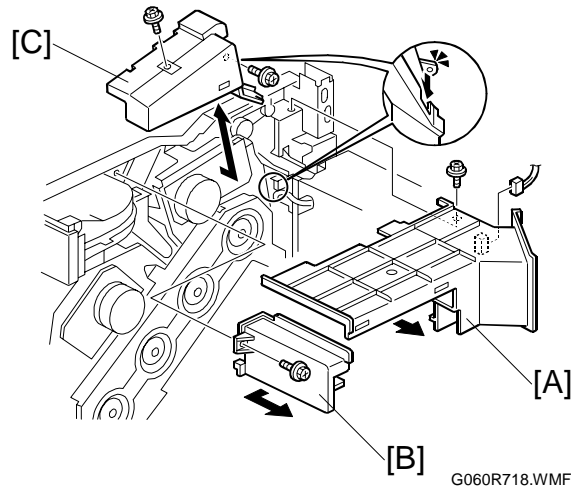

7. Black development clutch securing plate (☛ 3.10.3 DEVELOPMENT DRIVE MOTOR - CMY)
8. Development drive motor – K [D] (🔩 x 4, 📏 x 1)

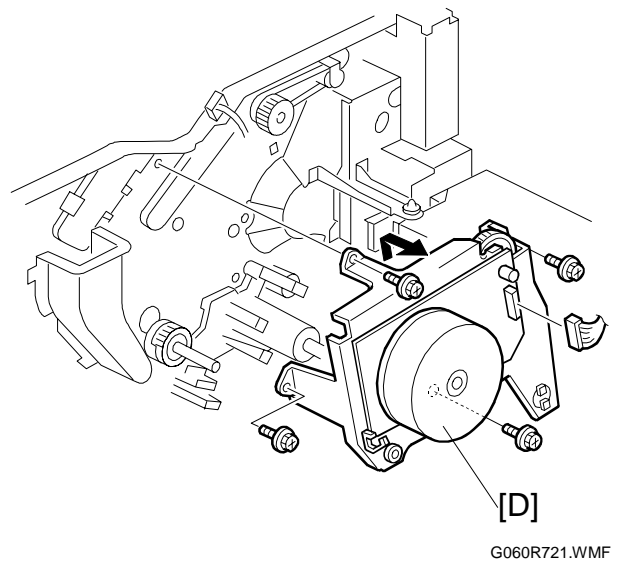

4. TROUBLESHOOTING

4.1 PROCESS CONTROL ERROR CONDITIONS

4.1.1 DEVELOPER INITIALIZATION RESULT

SP-3-005-006 (Developer Initialization Result)

No.	Result	Description	Possible Causes	Action
1	Successfully completed	Developer initialization is successfully completed.	-	-
2	Failure	Vt cannot be adjusted within $3.0 \pm 0.1V$.	1. Shielding tape is not removed.	1. Remove the shielding tape to supply developer to the unit.
			2. Development unit is not firmly installed, causing poor connection of the TD sensor connector.	2. Reinstall the development unit.
			3. TD sensor defective.	3. Replace the development unit.

Trouble-shooting

4.1.2 PROCESS CONTROL SELF-CHECK RESULT

SP3-975-001 (Process Control Self-check Result)

No.	Result	Description	Possible Causes	Action
1	Successfully completed	Process control self-check successfully completed.		
2	ID sensor adjustment error	Vsg cannot be adjusted within $4.0 \pm 0.5V$.	1. Dirty ID sensor (toner, dust, or foreign material)	1. Clean the ID sensor.
			2. Dirty transfer belt	2. Check the belt cleaning, and clean or replace the transfer belt.
			3. Scratched or damaged transfer belt	3. Replace the transfer belt.
			4. Defective ID sensor	4. Replace the ID sensor.
3	Vmin error	Vmin is not within the specified range.	Vmin is calculated during the self-check. Even when the calculated Vmin value is out of the specified range, an optimum value is automatically used instead. Therefore, this error code does not usually occur.	

No.	Result	Description	Possible Causes	Action
4	Sampling data error	Not enough data can be sampled.	1. ID sensor pattern density is too high or low. 2. Residual image on transfer belt 3. Toner dropped from development unit 4. Scratched or damaged transfer belt	1. Check the image development process and correct toner density if necessary. 2. Check the transfer belt cleaning unit. 3. Clean the development unit and correct toner density. 4. Replace the transfer belt.
5	Gamma error	Gamma is out of range. 0.3 > Gamma, or 6.0 < Gamma		
6	Vk error	Vk is out of range. -150 > Vk or 150 < Vk		
7	Vt error	Vt is out of range. 0.5 > Vt or 4.8 < Vt	1. Development unit not properly installed.	1. Check.
			2. Toner density is too low or high.	2. Check and/or correct toner density.
			3. TD sensor defective.	3. Replace development unit.
8	Sampling data error during LD power correction	Not enough data can be sampled during the LD power correction (if SP3-125-002 is set to "2").	See the possible causes and action for error codes 4, 5, and 6.	
9	Forced termination	Process control self-check was forcibly terminated.	A cover was opened or the main switch was turned off during the self-check.	

4.1.3 LINE POSITION ADJUSTMENT RESULT

SP5-993-007 (Line Position Adjustment Result)

No.	Result	Description	Note
01	Successfully completed	Data sampling was correctly done and line position adjustment was successfully completed.	
02	Out of adjustment range (over ±2 mm)	The calculated result for line position correction is greater than ±2 mm.	
03	Calculation Error	Distance between the lines is greater than ±2 mm.	
04	Sampling Error	Data sampling cannot be done properly.	
05	Descending slope error	The ascending or descending slope of the ID sensor signal wave is out of specification.	(See Note 1)
06	Ascending slope error		(See Note 1)
07	Pattern lines mismatch (less than 64 lines)	The detected number of pattern lines is less than 64.	(See Note 1)
08	Sampling time-out	Data sampling cannot be done within the allocated time.	
09	Sampling start error	The start mark cannot be detected within the allocated time.	
10	Pattern length mismatch	The pattern length is shorter or longer than specified.	(See Note 1)

No.	Result	Description	Note
11	Pattern lines mismatch (over 64 lines)	The detected number of pattern lines is over 64.	
12	Magnification mismatch	The calculated magnification value does not match any data in the laser power frequency adjustment data table.	
13	Toner condition	The machine is in the toner near-end or toner end condition.	
17	Not executed	The machine is not ready to do the line position adjustment manually from the user menu.	
18	Potential control error	Line position adjustment cannot be done due to failed potential control.	

Note 1: Concerning the error codes (05, 06, 07 or 10) which stop sampling data when either the front or rear ID sensor detect an error, the machine may display the error code for both ID sensors in some cases.

Possible causes of errors in the line position adjustment

	Possible Cause	Possible Error Code	Action
1	The pattern does not reach the proper density.	04, 05, 06, 07, 08, 09, 10	1. Clean the ID sensors. 2. Correct the toner density. 3. Correct the transfer current.
	1. Dirty ID sensor (toner, dust, or foreign material)		
	2. Incorrect toner density Low: ID sensor cannot detect the pattern lines. High: Lines may be partially blank due to improper toner density and/or paper transfer current.		
2	3. Incorrect transfer current	02, 03, 04, 05, 06, 10, 11, 12	1. Replace PCU 2. Replace transfer belt 3. Clean or replace transfer belt 4. Fix the high voltage leak 5. Check transfer belt cleaning and clean the belt 6. Clean the development unit and adjust the toner density 7. Clean the development unit and adjust the toner density
	The ID sensors are affected by electrical noise or dirt/damage on the transfer belt.		
	1. Scratched or damaged OPC drum		
	2. Scratched or damaged transfer belt		
	3. Dirty transfer belt		
	4. High voltage leak in transfer unit		
	5. Residual image on transfer belt		
	6. Toner dropped from development unit		
7. Carrier dropped from development unit			
3	The transfer belt is covered with toner.	All error codes	Check all units and high voltage cable connectors.
	Development does not work properly.		
4	None of the patterns are developed.	09, 04	Check all units and high voltage cable connectors.
	Development does not work properly.		

	Possible Cause	Possible Error Code	Action
5	Some of the patterns are not developed; Development does not work properly.	07, 08	Check all units and high voltage cable connectors.
6	The machine is not in the condition to execute the line position adjustment; The machine is in the toner near end or end condition. The machine is not ready to do the line position adjustment manually from the user menu. Line position adjustment cannot be done due to failed potential control.	13 17 18	Replenish toner. Wait until machine becomes the ready condition from the energy saver or auto off mode. Fix the problem causing the potential control error.
7	The MUSIC CPU is abnormal (1) No error code is displayed. However, the machine keeps displaying "execution" on the screen. In addition, the green LED on the BICU stays on or off under the following condition. 1. The MUSIC CPU resets due to electrical noise generated by a high voltage leak on a damaged OPC drum.	-	1. Fix the bias leak and/or replace PCU
8	The MUSIC CPU is abnormal (2) No error code is displayed. However, the machine keeps displaying "execution" on the screen. The green LED on the BICU keeps blinking faintly (this is normal) even under one of the following conditions. 1. Poor connection between the toner cartridge detection board and the memory chip on the toner cartridge 2. The memory chip on the toner cartridge fails.	-	1. Check the connection between the detection board and memory chip. 2. Replace the toner cartridge.

4.2 SERVICE CALL CONDITIONS

4.2.1 SUMMARY

There are 2 levels of service call conditions.

Level	Definition	Reset Procedure
A	Fusing unit SCs displayed on the operation panel. The machine is disabled. The user cannot reset the SC.	Turn the main switch off then on before entering SP mode. Reset the SC (set SP5-810 to 1), then turn the main switch off then on again.
B	Turning the operation switch or main power switch off then on resets the SC. Displayed on the operation panel. Re-displayed if they occurred after the main power switch is turned on again.	Turn the operation switch or main power switch off and on.

All SCs are logged.

- The number of SC codes detected can be checked with SP7-902.
- Printing logging data (SP5-990-004) in SP mode can check the latest 10 SC codes detected and total counters when the SC code is detected.

NOTE: 1) If the problem concerns electrical circuit boards, first disconnect then reconnect the connectors before replacing the PCBs.
2) If the problem concerns a motor lock, first check the mechanical load before replacing motors or sensors.

SC Classification

SC codes are classified by section as shown in the following table:

Class 1	Section	SC Code	Detailed section
1XX	Scanning	190 -	Unique for a specific model
2XX	Laser exposure	200 -	Polygon motor
		220 -	Synchronization control
		230 -	FGATE signal related
		240 -	LD control
		260 -	Magnification
		280 -	Unique for a specific model
3XX	Image development 1	300 -	Charge
		330 -	Drum potential
		350 -	Development
		380 -	Unique for a specific model
4XX	Image development 2	400 -	Image transfer
		420 -	Paper separation
		430 -	Cleaning
		440 -	Around drum
		460 -	Unit
		480 -	Others
5XX	Paper feed / Fusing	500 -	Paper feed
		515 -	Duplex
		520 -	Paper transport

Class 1	Section	SC Code	Detailed section
5XX	Paper feed / Fusing	530 -	Fan motor
		540 -	Fusing
		560 -	Others
		570 -	Unique for a specific model
6XX	Communication	600 -	Electrical counters
		620 -	Mechanical counters
		630 -	Account control
		640 -	CSS
		650 -	Network
		670 -	Internal data processing
		680 -	Unique for a specific model
7XX	Peripherals	700 -	Original handling
		710 -	
		730 -	Mail box
		740 -	Finisher
		750 -	Stapler (1)
		760 -	Stapler (2)
8XX	Controller	780 -	Unique for a specific model
		800 -	Error after ready condition
		820 -	Diagnostics error
		860 -	Hard disk
9XX	Others	880 -	Unique for a specific model
		900 -	Counter
		920 -	Memory
		990 -	Others

4.3 SC TABLE

SC No.	Item	Definition	Possible Cause	Related SCs	Troubleshooting Procedure	Type
SC195	Serial Number Mismatch	<ul style="list-style-type: none"> Serial number stored in the memory does not consist of the correct code. 	<ul style="list-style-type: none"> EEPROM defective BCU replaced without original EEPROM 		<p>Open the front cover and turn on the main switch. Check the serial number with SP5-811-002.</p> <p>If the stored serial number is incorrect, contact your product specialist for details of how to solve the problem.</p>	
SC201	Polygon motor error	<ul style="list-style-type: none"> The polygon mirror motor does not reach the targeted operating speed within 15 seconds after turning on. The lock signal does not become low within 15 seconds after turning off the polygon motor. . 	<ul style="list-style-type: none"> Polygon mirror motor error Abnormal GAVD behavior Cable disconnection 		<ol style="list-style-type: none"> Turn the main switch off and on. Check the cables. Replace the polygon motor. 	
SC220	Synch. detection signal error 1 220-001: Y 220-002: M 220-003: C 220-004: K0 220-005: K1	The front (for K&Y) or rear (for C&M) laser synchronizing detector board, which is used to determine the start timing of laser writing, does not send a signal while the polygon motor is operating normally and the LD is on.	<ul style="list-style-type: none"> Disconnection of the cable between front (K&Y) or rear (C&M) synchronizing detector board and the LD unit Incorrect installation of front (K&Y) or rear (C&M) synchronizing detector board (the beam does not target the photo detector.) Defective LD unit Defective BCU 		<ol style="list-style-type: none"> Turn the main switch off and on. Check the cable connection between front (for K&Y) or rear (for C&M) synchronizing detector board and the LD unit. Check or reinstall the front (for K&Y) or rear (for C&M) synchronizing detector board. Replace the front (for K&Y) or rear (for C&M) synchronizing detector board. Replace the LD unit. Replace the BCU. 	

SC No.	Item	Definition	Possible Cause	Related SCs	Troubleshooting Procedure	Type
SC 221	Synch. detection signal error 2 221-001: Y 221-002: M 221-003: C 221-004: K	Main scan length detection is not properly completed ten consecutive times. The front (for C&M) or rear (for K&Y) laser synchronizing detector boards are used for the main scan length detection, which automatically corrects the main-scan magnification.	<ul style="list-style-type: none"> • Damaged or disconnected cable between front (C&M) or rear (K&Y) laser synchronizing detector board and the LD unit • Incorrect installation of front (C&M) or rear (K&Y) synchronizing detector board (the beam does not target the photo detector.) • Defective front (C&M) or rear (K&Y) synchronizing detector board • Defective LD unit 		<p>After doing any of the following, print ten jobs or more to see if the same SC code is displayed:</p> <ol style="list-style-type: none"> 1. Turn the main switch off and on. 2. Check or replace the cable connecting front (for C&M) or rear (for K&Y) synchronizing detector board and the LD unit. 3. Check or reinstall the front (for C&M) or rear (for K&Y) synchronizing detector board. 4. Replace the front (for C&M) or rear (for K&Y) synchronizing detector board. 5. Replace the LD unit. 6. Replace the BCU. <p>If a synch. detector board cannot be replaced, do the following as a temporary measure:</p> <ul style="list-style-type: none"> • Disable main scan length detection (SP 2-919-001) 	

SC No.	Item	Definition	Possible Cause	Related SCs	Troubleshooting Procedure	Type
SC 230	FGATE error 230-001: Y 230-002: M 230-003: C 230-004: K	<p>The BCU generates the FGATE signal based on the registration sensor ON timing. Then, it sends the signal to the LD units. The LD units send a feedback signal to the BCU. When the LD units start emitting laser beams, the feedback signal changes from High to Low.</p> <p>The SC code is generated when the BCU receives no feedback signal (stays High) from the LD unit 1 second after paper reaches the position where the laser should start writing.</p>	<ul style="list-style-type: none"> Poor connection between BCU and LD units Defective BCU Defective LD unit 		<ol style="list-style-type: none"> Turn the main switch off and on. Check the cables between the LD units and the BCU. Replace the LD unit. Replace the BCU. 	
SC 231	FGATE timeout 231-001: Y 231-002: M 231-003: C 231-004: K	<p>When LD units emit laser beams to print a job, the feedback signal stays Low and becomes High after laser exposure for a page is completed. The SC code is detected in the following cases:</p> <ul style="list-style-type: none"> When the feedback signal stays Low 7 seconds after completing the laser exposure, or When the feedback signal stays Low until the laser exposure timing for the next page in multi-page print mode. 	<ul style="list-style-type: none"> Poor connection between BCU and LD units Defective BCU Defective LD unit 		<ol style="list-style-type: none"> Turn the main switch off and on. Check the cables between the LD units and the BCU. Replace the LD unit. Replace the BCU. 	

SC No.	Item	Definition	Possible Cause	Related SCs	Troubleshooting Procedure	Type
SC 240	LD over 240-001: Y 240-002: M 240-003: C 240-004: K	The power supply for the LD unit exceeds 67 mA.	<ul style="list-style-type: none"> • LD worn out (current/light output characteristics have changed.) • LD broken (short circuit) 		<ol style="list-style-type: none"> 1. Turn the main switch off and on. 2. Replace the LD unit. 	
SC 260	LD HP sensor not switched on (for K only)	During homing, it takes more than five seconds to switch the HP sensor on (the sensor actuator does not cover the sensor).	<ul style="list-style-type: none"> • Defective motor • Defective sensor • Mechanical problem when switching the actuator • Brown fuse (FU81) on the Power supply unit 		<ol style="list-style-type: none"> 1. Turn the main switch off and on. 2. Check the sensor actuator position of the LD positioning motor. 3. Replace the LD positioning motor. 4. Replace the LD home position sensor. 5. Check and/or replace the PSU. 	
SC 261	LD HP sensor not switched off (for K only)	After the laser beam pitch was changed, it takes more than five seconds for the HP sensor to switch off.	<ul style="list-style-type: none"> • Defective motor • Defective sensor • Mechanical problem when switching the actuator • Brown fuse (FU81) on the Power supply unit 		<ol style="list-style-type: none"> 1. Turn the main switch off and on. 2. Check the sensor actuator position of the LD positioning motor. 3. Replace the LD positioning motor. 4. Replace the LD home position sensor. 5. Check and/or replace the PSU. 	

SC No.	Item	Definition	Possible Cause	Related SCs	Troubleshooting Procedure	Type
SC 285	Line position adjustment (MUSIC) error	Line position adjustment fails three consecutive times.	<ul style="list-style-type: none"> • Pattern sampling error due to insufficient image density of patterns used for the adjustment • Inconsistency in the sampling line position adjustment pattern due to dust on the pattern, damage to the OPC drum, damage or toner dropped on the transfer belt, or a dirty or defective ID sensor 		<ol style="list-style-type: none"> 1. Turn the main switch off and on. 2. Check and fix the problem that causes low image density. . 3. Clean or replace the transfer belt and/or the ID sensor. 4. Replace the PCU or clean the development unit that causes toner to drop on the transfer belt. 	
SC 370	TD sensor [K]: Adjustment error	During the developer initialization, the output value of the TD sensor is without the adjustment range ($3.0 \pm 0.1V$).	<ul style="list-style-type: none"> • Poor connection (TD sensor outputs is less than 0.5V.) • Defective TD sensor 		<ol style="list-style-type: none"> 1. Turn the main switch off and on. 2. Reset the related color development unit. 3. Replace the related color development unit. 	
SC 371	TD sensor [Y]: Adjustment error					
SC 372	TD sensor [C]: Adjustment error					
SC 373	TD sensor [M] : Adjustment error					
SC 374	Vt error [K]	During the image development, Vt value is less than 0.5V.	<ul style="list-style-type: none"> • Poor connection (TD sensor outputs is less than 0.5V.) • Defective TD sensor 		<ol style="list-style-type: none"> 1. Turn the main switch off and on. 2. Reset the related color development unit. 3. Replace the related color development unit. 	
SC 375	Vt error [Y]					
SC 376	Vt error [C]					
SC 377	Vt error [M]					

SC No.	Item	Definition	Possible Cause	Related SCs	Troubleshooting Procedure	Type
SC 380	Black development motor error	When the motor speed is within the target level, the motor sends a lock signal (High to Low at CN214-5) to the BCU. SC380 is detected under the following conditions: <ul style="list-style-type: none"> • The Lock signal stays High 2 seconds after the motor turns on. • The Lock signal stays Low 2 seconds after the motor turns off. • The Lock signal stays High for more than 2 seconds while the motor is on. 	<ul style="list-style-type: none"> • Defective motor • Defective BCU 		<ol style="list-style-type: none"> 1. Turn the main switch off and on. 2. Replace the motor. 3. Replace the BCU. 	
SC 381	Color development motor error					
SC 385	ID sensor VSG adjustment error	Vsg is the out of adjustment range during a process control self-check. Adjustment range: $4.0 \pm 0.5V$	<ul style="list-style-type: none"> • Defective ID sensor • Dirty ID sensor • ID sensor disconnected • Dirty drum (cleaning incomplete) 		<ol style="list-style-type: none"> 1. Turn the main switch off and on. 2. Clean the ID sensor and adjacent parts. 3. Check the drum cleaning condition. 4. Check the ID sensor connector. 5. Replace the ID sensor. 	
SC 386	Development gamma error K	Any of the following conditions happens three consecutive times: <ul style="list-style-type: none"> • When the development gamma is out of the following range: $0.3 \leq \gamma \leq 6.0$ • When V_k is out of the following range: $-150V \leq V_k \leq 150V$ • Development gamma calculation error 	<ul style="list-style-type: none"> • Unsuitable toner density • Toner supply mechanism problem • Laser exposure problem • Image transfer problem 		<ol style="list-style-type: none"> 1. Turn the main switch off and on . 2. Check the process control self-check result (SP3-975). If the result is not "1", fix the problem according to the table in section 4.1.2. 3. Print a full color image by disabling SC detection (SP5-809-001) and check if the image quality is OK. If the image quality is not OK, fix the problem. Then, enable the SC detection again. 	
SC 387	Development gamma error Y					
SC 388	Development gamma error C					
SC 389	Development gamma error M					

SC No.	Item	Definition	Possible Cause	Related SCs	Troubleshooting Procedure	Type
SC 390	Development Bias output error	<p>The high voltage supply board (C/B) monitors the circuit and detects abnormal conditions such as a voltage leak or no output condition. If this happens, the high voltage supply board sends an error signal (High to Low at CN204-A18) to the BCU.</p> <p>The BCU monitors this signal every 2 ms and generates this SC code when the error condition occurs 250 consecutive times.</p>	<ul style="list-style-type: none"> • Loose connection • Defective power pack C/B output • Damaged cable • Defective development unit • Defective BCU 		<ol style="list-style-type: none"> 1. Turn the main switch off and on. 2. Check if the harness and cables are properly connected. 3. Disconnect the high voltage supply cables from the bias terminals on the high voltage supply board C/B. Measure the DC voltage using a multi-meter. <ul style="list-style-type: none"> • Replace the high voltage supply board if no voltage is supplied. 4. If the result is OK at step 2, check if the high voltage supply cable or development unit is grounded. <ul style="list-style-type: none"> • Replace the high voltage supply cable if it damages. • Replace the development unit if it damages. 5. Check the PWM signals are sent to the high voltage supplied board from the BCU. Replace the BCU or harness between the BCU and high voltage supply board if the voltage is 0. 	
SC 391-01	Charge AC: output error 391-01: K 391-02: Y 391-03: M 391-04: C	<p>The high voltage supply board sends the feedback signal (CN228-2 to 5; MCYK). The BCU monitors these feedback signals every 8 ms. If the average of the sampled data is not within the control target 30 consecutive times, this SC code is generated.</p>	<ul style="list-style-type: none"> • Power pack disconnected • Charge receptacle or terminal • Defective PCU bias input terminal • Incorrect power pack B/C output • Damaged cable • Defective BCU 		<ol style="list-style-type: none"> 1. Turn the main switch off and on. 2. Check the connector. 3. Check the PCU charge voltage input (the spring/conducting shaft) or replace the PCU. 4. Replace the power pack B/C. 5. Replace the cable. 6. Replace the BCU. 	

SC No.	Item	Definition	Possible Cause	Related SCs	Troubleshooting Procedure	Type
SC 460-001	Thermistor 1 error (open circuit)	When the temperature detected by thermistor 1, which is at the left (fusing unit) side of the laser optics unit, is less than -30°C for 10 seconds consecutively, the BCU determines that the circuit is opened and displays this SC code..	<ul style="list-style-type: none"> • Thermistor 1 defective • Cable connection error • BCU defect 		<ol style="list-style-type: none"> 1. Turn the main switch off and on. 2. Check the cable connections. 3. Replace the thermistor. 4. Replace the BCU. 	
SC 460-002	Thermistor 1 error (short circuit)	When the temperature detected by the thermistor 1, which is at the left (fusing unit) side of the laser optics unit, is higher than 70°C for 10 seconds consecutively, the BCU determines that the circuit is shorted and displays this SC code	<ul style="list-style-type: none"> • Thermistor 1 defective • Cable connection error • BCU defect 		<ol style="list-style-type: none"> 1. Turn the main switch off and on. 2. Check the cable connections. 3. Replace the thermistor. 4. Replace the BCU. 	
SC 461-001	Thermistor 2 error (open circuit)	When the temperature detected by the thermistor 2, which is at the right (paper feed section) side of the laser optics unit, is less than -30°C for 10 seconds consecutively, the BCU determines that the circuit is opened and displays this SC code.	<ul style="list-style-type: none"> • Thermistor 2 defective • Cable connection error • BCU defect 		<ol style="list-style-type: none"> 1. Turn the main switch off and on. 2. Check the cable connections. 3. Replace the thermistor. 4. Replace the BCU. 	

SC No.	Item	Definition	Possible Cause	Related SCs	Troubleshooting Procedure	Type
SC 461-002	Thermistor 2 error (short circuit)	When the temperature detected by the thermistor 2, which is at the right (paper feed section) side of the laser optics unit, is higher than 70°C for 10 seconds consecutively, the BCU determines that the circuit is shorted and displays this SC code	<ul style="list-style-type: none"> • Thermistor 2 defective • Cable connection error • BCU defect 		<ol style="list-style-type: none"> 1. Turn the main switch off and on. 2. Check the cable connections. 3. Replace the thermistor. 4. Replace the BCU. 	
SC 471	Transfer belt H.P. error	The transfer belt HP sensor signal does not change from Low to High (home position) or vice versa 1 second after the transfer belt contact motor turns on.	<ul style="list-style-type: none"> • Transfer belt unit not set properly • Defective transfer belt H.P. sensor and/or transfer belt set sensor • Defective transfer belt contact motor • Transfer belt unit problem 		<ol style="list-style-type: none"> 1. Turn the main switch off and on. 2. Reset the transfer belt unit. 3. Clean or replace the transfer belt H.P. sensor and/or transfer belt set sensor. 4. Replace the transfer belt contact motor. 5. Check the contact and release mechanism of the transfer belt unit. 	
SC 490	Transfer bias / paper attraction roller bias leak error	<p>The high voltage supply board (T/PA/CL) monitors the circuit and detects current leaks. If this happens, the high voltage supply board sends a SC signal (High to Low at CN213-8) to the BCU.</p> <p>The BCU monitors this signal every 2 ms and generates this SC code when the error condition occurs 250 consecutive times.</p>	<ul style="list-style-type: none"> • Defective high voltage supply board (T/PA/CL) • Damaged transfer belt • Transfer unit • Damaged high voltage supply cables • Damaged cables between the BCU and high voltage supply board • Defective BCU 		<ol style="list-style-type: none"> 1. Turn the main switch off and on. 2. Check the transfer unit and replace the belt and/or the transfer unit if any damage is found. 3. Replace the high voltage supply board (T/PA/CL). 4. Check and/or replace the high voltage supply cables. 5. Check and/or replace the dc cables between the BCT and high voltage supply board. 6. Replace the BCU. 	

SC TABLE

23 February 2001

SC No.	Item	Definition	Possible Cause	Related SCs	Troubleshooting Procedure	Type
SC 501	Paper Tray 1 error	When the tray lift motor is turned on, if the upper limit is not detected within 10 seconds, the machine asks the user to reset the tray. If this condition occurs three consecutive times, the SC is generated.	<ul style="list-style-type: none"> • Defective paper lift sensor • Defective tray lift motor • Defective bottom plate lift mechanism 		<ol style="list-style-type: none"> 1. Turn the main switch off and on. 2. Check if the bottom plate smoothly moves up and down manually. 3. Check and/or replace the paper lift sensor. 4. Check and/or replace the tray lift motor. 	
SC 502	Paper Tray 2 error					

SC No.	Item	Definition	Possible Cause	Related SCs	Troubleshooting Procedure	Type
SC 503-01	Tray 3 error (Paper Feed Unit or LCT)	<p>For the paper feed unit: When the tray lift motor is turned on, if the upper limit is not detected within 18 seconds, the machine asks the user to reset the tray. If this condition occurs three consecutive times, the SC is generated.</p> <p>For the LCT: This SC is generated under the following conditions:</p> <ul style="list-style-type: none"> • If the upper or lower limit is not detected within 15 seconds when the tray lift motor is turned on to lift up or lower the tray • If the paper stack is not transported within a specific number of pulses after the tray motor and stack transport clutch turn on to transport the paper stack • If the end fence home position sensor stays ON for a specific number of pulses after the tray motor and stack transport clutch turn on to transport the paper stack. 	<p>For the paper feed unit:</p> <ul style="list-style-type: none"> • Defective tray lift motor or connector disconnection • Defective lift sensor or connector disconnection <p>•</p> <p>For the LCT:</p> <ul style="list-style-type: none"> • Defective stack transport clutch or connector disconnection • Defective tray motor or connector disconnection • Defective end fence home position sensor or connector disconnection • Defective upper limit sensor or connector disconnection • Defective tray lift motor or connector disconnection 		<ol style="list-style-type: none"> 1. Turn the main switch off and on. 2. Check the cable connections. 3. Check and/or replace the defective component. 	

SC No.	Item	Definition	Possible Cause	Related SCs	Troubleshooting Procedure	Type
SC 503-02	Tray 3 error (Paper Feed Unit or LCT)	<ul style="list-style-type: none"> • If the following condition occurs 3 consecutive times, this SC is generated. <p>For the paper feed unit: When the main switch is turned or when the tray is set and if the upper limit is already detected, the lift motor turns on to lower the bottom plate until the lift sensor goes off. If the motor turns on for 7 seconds or more, the machine asks the user to reset the tray.</p> <p>For the LCT: When the main switch is turned on or when the LCT is set, if the end fence is not in the home position (home position sensor ON), the tray lift motor stops.</p>	<p>For the paper feed unit:</p> <ul style="list-style-type: none"> • Defective tray lift motor or connector disconnection • Defective lift sensor or connector disconnection <p>For the LCT:</p> <ul style="list-style-type: none"> • Defective stack transport clutch or connector disconnection • Defective tray motor or connector disconnection • Defective end fence home position sensor or connector disconnection 		<ol style="list-style-type: none"> 1. Turn the main switch off and on. 2. Check the cable connections. 3. Check and/or replace the defective component. 	
SC 504-01	Tray 4 error (3 Tray Paper Feed Unit)	<p>When the tray lift motor is turned on, if the upper limit is not detected within 18 seconds, the machine asks the user to reset the tray. If this condition occurs three consecutive times, the SC is generated.</p>	<ul style="list-style-type: none"> • Defective tray lift motor or connector disconnection • Defective lift sensor or connector disconnection 		<ol style="list-style-type: none"> 1. Turn the main switch off and on. 2. Check the cable connections. 3. Check and/or replace the defective component. 	

SC No.	Item	Definition	Possible Cause	Related SCs	Troubleshooting Procedure	Type
SC 504-02	Tray 4 error (3 Tray Paper Feed Unit)	When the main switch is turned or when the tray is set and if the upper limit is already detected, the lift motor turns on to lower the bottom plate until the lift sensor goes off. If the motor turns on for 7 seconds or more, the machine asks the user to reset the tray. If this condition occurs 3 consecutive times, this SC is generated.	<ul style="list-style-type: none"> Defective tray lift motor or connector disconnection Defective lift sensor or connector disconnection 		<ol style="list-style-type: none"> Turn the main switch off and on. Check the cable connections. Check and/or replace the defective component. 	
SC 530	Fusing fan motor error	The BCU does not receive the lock signal (CN210-B5) 5 seconds after turning on the fusing fan.	<ul style="list-style-type: none"> Defective fusing fan motor or connector disconnection Defective BCU 		<ol style="list-style-type: none"> Turn the main switch off and on. Check the connector and/or replace the fusing fan motor. Replace the BCU. 	
SC 541	Heating roller thermistor error	The temperature measured by the heating roller thermistor does not reach 7 °C for ten seconds.	<ul style="list-style-type: none"> Loose connection of the heating roller thermistor Defective heating roller thermistor Defective BCU 		<ol style="list-style-type: none"> Check if the heating roller thermistor is firmly connected. Replace the fusing unit. Replace the BCU. 	A
SC 542	Heating roller warm-up error	After the main switch is turned on or the cover is closed, the heating roller temperature does not reach the ready temperature within 60 seconds during fusing unit warm-up.	<ul style="list-style-type: none"> Heating roller fusing lamp broken Defective heating roller thermistor Defective BCU 		<ol style="list-style-type: none"> Check if the heating roller thermistor is firmly connected. Replace the fusing unit. Replace the BCU. 	A
SC 543	Heating roller fusing lamp overheat	The detected fusing temperature stays at 200 °C or more for five seconds.	<ul style="list-style-type: none"> Defective PSU Defective BCU 		<ol style="list-style-type: none"> Replace the PSU. Replace the BCU. 	A

SC No.	Item	Definition	Possible Cause	Related SCs	Troubleshooting Procedure	Type
SC 544	Heating roller fusing lamp low temperature error	During stand-by mode or a print job, the detected heating roller temperature stays at 50 °C or less for five seconds.	<ul style="list-style-type: none"> Loose connection between the fusing unit and the main frame Defective heating roller thermistor Defective PSU Defective BCU 		<ol style="list-style-type: none"> Check the connection between the fusing unit and main frame. Replace the fusing unit. Replace the PSU. Replace the BCU. 	A
SC 545	Heating roller fusing lamp consecutive full power	When the fusing unit is not running in the Ready condition, the heating roller fusing lamp keeps on with full power for 30 consecutive seconds.	<ul style="list-style-type: none"> Heating roller thermistor out of position 		<ol style="list-style-type: none"> Replace the fusing unit. 	A
SC 546	Heating roller fusing lamp temperature fluctuation	The heating roller temperature changes by ± 20 °C or more in one second. This occurs three times in one minute or two consecutive times.	<ul style="list-style-type: none"> Loose connection of the thermistor Loose connection between the fusing unit and main frame 		<ol style="list-style-type: none"> Check if the fusing unit is properly set and connected to the main frame. Check if the heating roller thermistor connector is firmly connected. Replace the fusing unit. 	A
SC 551	Pressure roller thermistor error	The measured pressure roller temperature does not reach 7°C for 30 seconds.	<ul style="list-style-type: none"> Loose connection of pressure roller thermistor Defective pressure roller thermistor Defective BCU 		<ol style="list-style-type: none"> Check that the pressure roller thermistor is firmly connected. Replace the fusing unit. Replace the BCU. 	A
SC 552	Pressure roller warm-up error	After the main switch is turned on or the door is closed, the pressure roller temperature does not reach the ready temperature within 150 seconds during fusing unit warm-up.	<ul style="list-style-type: none"> Pressure roller fusing lamp broken Defective pressure roller thermistor Defective BCU 		<ol style="list-style-type: none"> Check if the pressure roller thermistor is firmly connected. Replace the fusing unit. Replace the BCU. 	A
SC 553	Pressure roller fusing lamp overheat	The detected pressure roller temperature stays at 200 °C or more for five seconds.	<ul style="list-style-type: none"> Defective PSU Defective BCU 		<ol style="list-style-type: none"> Replace the fusing unit. Replace the PSU. Replace the BCU. 	A

SC No.	Item	Definition	Possible Cause	Related SCs	Troubleshooting Procedure	Type
SC 554	Pressure roller fusing lamp low temperature error	During stand-by mode or printing, the detected pressure roller temperature stays at 50 °C or less for five seconds.	<ul style="list-style-type: none"> Loose connection between the fusing unit and the machine Defective pressure roller thermistor Defective PSU Defective BCU 		<ol style="list-style-type: none"> Check the connection between the fusing unit and main frame. Replace the fusing unit. Replace the PSU. Replace the BCU. 	A
SC 555	Pressure roller fusing lamp consecutive full power	When the fusing unit is not running in the Ready condition, the pressure roller fusing lamp keeps ON with full power for 100 consecutive seconds.	<ul style="list-style-type: none"> Pressure roller thermistor out of position 		<ol style="list-style-type: none"> Replace the fusing unit. 	A
SC 556	Pressure roller fusing lamp temperature fluctuation	The pressure roller temperature changes by ± 20 °C or more in one second. This occurs three times in one minute or two consecutive times.	<ul style="list-style-type: none"> Loose connection of the pressure roller thermistor Loose connection between the fusing unit and main frame 		<ol style="list-style-type: none"> Check if the fusing unit is properly set and connected to the main frame. Check if the pressure roller thermistor connector is firmly connected. Replace the fusing unit. 	A
SC 560	Zero cross error	When the main switch is turned on, the machine checks how many zero-cross signals are generated during 500 ms. If the number of zero-cross signal generated is either more than 66 or less than 45 and when this condition is detected 10 consecutive times, this code is displayed.	<ul style="list-style-type: none"> Electrical noise in the supply from the power cord 		<ol style="list-style-type: none"> Replace the PSU. 	A

SC No.	Item	Definition	Possible Cause	Related SCs	Troubleshooting Procedure	Type
SC 621	Finisher/mailbox communication error	While the BCU communicates with an optional unit, an SC code is displayed if one of following conditions occurs.	<ul style="list-style-type: none"> • Cable problems • BCU problems • PSU problems in the machine 		<ol style="list-style-type: none"> 1. Turn the main switch off and on. 2. Check if the cables of peripherals are properly connected. 3. Replace the PSU if no power is supplied to peripherals. 4. Replace the BCU or main board of peripherals. 	
SC 622	Bank communication error	1. The BCU receives a signal which is generated by the peripherals only just after the main switch is turned on.	<ul style="list-style-type: none"> • Main board problems in the peripherals 			
SC 623	Duplex unit communication error	2. When the BCU does not receive an OK signal from a peripheral 100ms after sending a command to it. The BCU resends the command. The BCU does not receive an OK signal after sending the command 3 times.	<ul style="list-style-type: none"> • Cable problems • BCU problems • PSU problems in the machine • Duplex control board problem 		<ol style="list-style-type: none"> 1. Turn the main switch off and on. 2. Check if the cable of the duplex inverter unit is properly connected. 3. Replace the PSU if no power is supplied to the peripherals. 4. Replace the duplex control board in the inverter unit. 	
SC 640	BCU - Controller communication error (checksum error)	The check sum of the interface between the BCU and controller is not the same.	<ul style="list-style-type: none"> • Defective controller • Defective PCU 		<ol style="list-style-type: none"> 1. Turn the main switch off and on. 2. Replace the controller. 3. Replace the BCU. 	CTL
SC 641	BCU – Controller communication error (no response)	The controller does not receive any response from the BCU three consecutive times when sending a signal every 100ms.	<ul style="list-style-type: none"> • Loose connection • Defective controller • Defective BCU 		<ol style="list-style-type: none"> 1. Turn the main switch off and on. 2. Check the connection between the BCU and controller. 3. Replace the controller. 4. Replace the BCU. 	CTL
SC 670	No response from BCU at power on	When the main power is turned on or the machine starts warming up from energy-saving mode, the controller does not receive a command signal from the BCU.	<ul style="list-style-type: none"> • Loose connection • Defective controller • Defective BCU 		<ol style="list-style-type: none"> 1. Turn the main switch off and on. 2. Check the connection between the BCU and controller. 3. Replace the controller. 4. Replace the BCU. 	CTL

SC No.	Item	Definition	Possible Cause	Related SCs	Troubleshooting Procedure	Type
SC 680	BCU/ MUSIC communication error	After the engine CPU sends a message, the Music CPU does not respond within five seconds three consecutive times.	<ul style="list-style-type: none"> • Toner cartridge memory chip loose connection • Memory chip problem • Memory chip cable wiring problem 		<ol style="list-style-type: none"> 1. Turn the main switch off and on. 2. Check if the toner cartridge is installed correctly. 3. Replace the toner cartridge. 4. Check if the harnesses are not damaged. 5. Replace the BCU. 	
SC 687	Memory address command error	The BCU does not receive a memory address command from the controller 60 seconds after paper is in the position for registration.	<ul style="list-style-type: none"> • Loose connection • Defective controller • Defective BCU 		<ol style="list-style-type: none"> 1. Turn the main switch off and on. 2. Check if the controller is firmly connected to the BCU. 3. Replace the controller. 4. Replace the BCU. 	
SC 722	Finisher jogger motor error	<ul style="list-style-type: none"> • The jogger fences of the finisher do not return to home position within a specific time. • The finisher jogger motor does not leave home position within a given time. 	<ul style="list-style-type: none"> • Defective jogger H.P. sensor • Loose connection • Defective jogger motor 		<ol style="list-style-type: none"> 1. Turn the main switch off and on. 2. Check the connection of jogger H.P. sensor and jogger motor connectors 3. Replace the jogger H.P. sensor. 4. Replace the jogger motor. 	
SC 724	Finisher staple hammer motor error	Stapling does not finish within 150 ms after the staple hammer motor turns on.	<ul style="list-style-type: none"> • Staple jam • Loose connection • Overload caused by stapling too many pages • Defective staple hammer motor 		<ol style="list-style-type: none"> 1. Turn the main switch off and on. 2. Check if the staple hammer motor connector is properly connected. 3. Check if the staple jam occurs. 4. Replace the staple hammer motor. 	
SC 725	Finisher stack feed-out motor error	The stack feed-out belt H.P. sensor does not activate within a specified time after the stack feed-out motor turns on.	<ul style="list-style-type: none"> • Defective stack feed-out H.P. sensor • Loose connection • Stack feed-out motor overload • Defective stack feed-out motor 		<ol style="list-style-type: none"> 1. Turn the main switch off and on. 2. Check if the connectors of the stack feed-out H.P. sensor and motor are properly connected. 3. Replace the stack feed-out H.P. sensor. 4. Replace the stack feed-out motor. 	

SC No.	Item	Definition	Possible Cause	Related SCs	Troubleshooting Procedure	Type
SC 726	Finisher shift tray 1 lift motor error	<ul style="list-style-type: none"> The upper stack height 1 sensor is activated consecutively (detecting paper) for 15 seconds after the shift tray starts moving up. The upper stack height sensor 1 is deactivated consecutively (not detecting paper) for 15 seconds after the shift tray starts moving down. When the upper tray moves from lower paper exit to the upper paper exit, the upper stack height 1 sensor is activated. 	<ul style="list-style-type: none"> Loose connection Defective upper stack height 1 sensor Defective shift tray 1 lift motor Motor overload 		<ol style="list-style-type: none"> Turn the main switch off and on. Check if the connectors of the sensor and motor are properly connected. Replace the upper stack height 1 sensor. Replace the shift tray 1 lift motor. 	
SC 727	Finisher stapler rotation motor error	The stapler cannot return to its home position within a specified time after the stapler rotation motor starts rotating.	<ul style="list-style-type: none"> Loose connection Defective stapler rotation motor Motor overload 		<ol style="list-style-type: none"> Turn the main switch off and on. Check if the stapler rotation motor connector is properly connected. Replace the stapler rotation motor. 	
SC 729	Finisher punch motor error	The punch home position is not detected within 250 ms after the punch clutch turns on.	<ul style="list-style-type: none"> Loose connection Defective punch H.P. sensor Defective punch clutch Defective punch hole motor 		<ol style="list-style-type: none"> Turn the main switch off and on. Check if the connectors of sensor, clutch and/or motor are properly connected. Replace the punch H.P. sensor. Replace the punch clutch. Replace the punch hole motor. 	
SC 730	Finisher stapler motor error	The stapler home position is not detected within a specified time after the staple motor turns on.	<ul style="list-style-type: none"> Loose connection Defective stapler H.P. sensor Defective stapler motor 		<ol style="list-style-type: none"> Turn the main switch off and on. Check if the connectors of the sensor and motor are properly connected. Replace the stapler H.P. sensor. Replace the stapler motor. 	

SC No.	Item	Definition	Possible Cause	Related SCs	Troubleshooting Procedure	Type
SC 731	Finisher exit guide plate motor error	The exit guide plate open sensor is not activated within a specified time after the exit guide plate motor turns on.	<ul style="list-style-type: none"> Loose connection Defective exit guide plate open sensor Defective exit guide plate motor 		<ol style="list-style-type: none"> Turn the main switch off and on. Check if the connectors of the sensor and motor are properly connected. Replace the exit guide plate open sensor. Replace the exit guide plate motor. 	
SC 732	Finisher tray 1 shift motor error	Tray 1 home position is not detected within a specified time after the tray 1 shift motor turns on.	<ul style="list-style-type: none"> Loose connection Defective tray shift 1 sensor Defective tray 1 shift motor 		<ol style="list-style-type: none"> Turn the main switch off and on. Check if the connectors of the sensor and motor are properly connected. Replace the tray shift 1 sensor. Replace the tray 1 shift motor. 	
SC 733	Finisher tray 2 lift motor error	<ul style="list-style-type: none"> The lower stack height 1 sensor is activated consecutively (detecting paper) for 15 seconds after the shift tray starts moving up. The lower stack height sensor 1 is deactivated consecutively (not detecting paper) for 15 seconds after the shift tray starts moving down. 	<ul style="list-style-type: none"> Loose connection Defective lower stack height 1 sensor Defective tray 2 lift motor Motor overload 		<ol style="list-style-type: none"> Turn the main switch off and on. Check if the connectors of the sensor and motor are properly connected. Replace the lower stack height 1 sensor. Replace the tray 2 lift motor. 	
SC 734	Finisher tray 2 shift motor error	Tray 2 home position is not detected within a specified time after the tray 2 shift motor turns on.	<ul style="list-style-type: none"> Loose connection Defective tray shift 2 sensor Defective tray 2 shift motor 		<ol style="list-style-type: none"> Turn the main switch off and on. Check if the connectors of the sensor and motor are properly connected. Replace the tray shift 2 sensor. Replace the tray 2 shift motor. 	
SC 818	Watch-dog error	While the system program is running, other processes do not operate at all.	<ul style="list-style-type: none"> Defective controller Software error 		<ol style="list-style-type: none"> Turn the main switch off and on. Replace the controller. See NOTE 1 at the end of the SC table 	CTL

SC No.	Item	Definition	Possible Cause	Related SCs	Troubleshooting Procedure	Type
SC 819	Fatal error					
[696E]	Process error	System completely down	<ul style="list-style-type: none"> Defective RAM DIMM Defective ROM DIMM Defective controller Software error 		<ol style="list-style-type: none"> Turn the main switch off and on. Check and/or replace the RAM DIMM. Check and/or replace the ROM DIMM. Replace the controller. See NOTE at the end of the SC table. 	CTL
[766D]	Memory error	Unexpected system memory size				
SC820	Self-diagnostics error: CPU [XXXX]: Detailed error code					
[0001] to [06FF]	CPU error	During the self-diagnostic, the controller CPU detects an error. There are 47 types of error code (0001 to 4005) depending on the cause of the error. The CPU detects an error and displays the specific error code with the program address where the error occurs).	<ul style="list-style-type: none"> System firmware problem Defective controller 		<ol style="list-style-type: none"> Turn the main switch off and on. Reinstall the controller system firmware. Replace the controller. <p>When the problem cannot be fixed with the above procedure, the following information displayed on the screen needs to be fed back to a technical support center.</p> <ul style="list-style-type: none"> SC code Detailed error code Program address 	CTL
[0702] [0709] [070A]	CPU/Memory Error		<ul style="list-style-type: none"> System firmware problem Defective RAM-DIMM Defective controller 		<ol style="list-style-type: none"> Turn the main switch off and on. Reinstall the controller system software. Replace the RAM-DIMM. Replace the controller. 	CTL
[0801] to [4005]	CPU error	Same as [0001]				CTL

SC No.	Item	Definition	Possible Cause	Related SCs	Troubleshooting Procedure	Type
SC 821 [0D05]	Self-diagnosis error: ASIC	The CPU checks if the ASIC timer works properly compared with the CPU timer. If the ASIC timer does not function in the specified range, this SC code is displayed.	<ul style="list-style-type: none"> System firmware problem Defective RAM-DIMM Defective controller 		<ol style="list-style-type: none"> Turn the main switch off and on. Reinstall the controller system firmware. Replace the RAM-DIMM. Replace the controller board. 	CTL
SC822	Self-diagnostic error: HDD (Hard Disk Drive)	[XXXX]: Detailed error code				
[3003]	Timeout error	When the main switch is turned on or starting the self-diagnostic, the HDD stays busy for the specified time or more.	<ul style="list-style-type: none"> Loose connection Defective HDD Defective controller 		<ol style="list-style-type: none"> Turn the main switch off and on. Check that the HDD is properly connected to the controller. Replace the HDD. Replace the controller. 	CTL
[3004]	Command error					
SC 823	Self-diagnostic error: NIB	[XXXX]: Detailed error code				
[6101]	MAC address check sum error	The result of the MAC address check sum does not match the check sum stored in ROM.	<ul style="list-style-type: none"> Defective controller 		<ol style="list-style-type: none"> Turn the main switch off and on. Replace the controller. 	CTL
[6104]	PHY IC error	The PHY IC on the controller cannot be properly recognized.				
[6105]	PHY IC loop-back error	An error occurred during the loop-back test for the PHY IC on the controller.				
SC 824 [1401]	Self-diagnosis error: Standard NVRAM	The controller cannot recognize the standard NVRAM installed or detects that the NVRAM is defective.	<ul style="list-style-type: none"> Loose connection Defective standard NVRAM Defective controller 		<ol style="list-style-type: none"> Turn the main switch off and on. Check the standard NVRAM is firmly inserted into the socket. Replace the NVRAM. Replace the controller. 	CTL

SC No.	Item	Definition	Possible Cause	Related SCs	Troubleshooting Procedure	Type
SC 827	Self-diagnostic error: Standard SRAM DIMM [XXXX]: Detailed error code					
[0201]	Verification error	Error detected during a write/verify check for the standard RAM (SRAM DIMM).	<ul style="list-style-type: none"> Loose connection Defective SRAM DIMM Defective controller 		<ol style="list-style-type: none"> Turn the main switch off and on. Replace the SRAM DIMM. Replace the controller. 	CTL
SC 828	Self-diagnostic error : ROM [XXXX]: Detailed error code					
[0101]	Check sum error 1	The boot monitor and OS program stored in the ROM DIMM is checked. If the check sum of the program is incorrect, this SC code is displayed.	<ul style="list-style-type: none"> Defective ROM DIMM Defective controller 		<ol style="list-style-type: none"> Turn the main switch on and off. Replace the ROM DIMM Replace the controller. 	CTL
[0104]	Check sum error 2	All areas of the ROM DIMM are checked. If the check sum of all programs stored in the ROM DIMM is incorrect, this SC code is displayed.				
[0105]	ROM error	The ROM DIMM is not of the recognized type.				
SC829	Self-diagnosis error: optional RAM [XXXX]: Detailed error code					
[0302]	Composition error (Slot 0)	The result of checking the composition data of the RAM in Slot 0 (CN5) on the controller is incorrect.	<ul style="list-style-type: none"> Not specified RAM DIMM installed Defective RAM DIMM 		<ol style="list-style-type: none"> Turn the main switch off and on. Replace the RAM DIMM. Replace the controller board. 	CTL
[0401]	Verification error (Slot 1)	The data stored in the RAM in Slot 1 does not match the data when reading.				
[0402]	Composition error (Slot 1)	The result of checking the composition data of the RAM in Slot 1 (CN6) on the controller is incorrect.				

SC No.	Item	Definition	Possible Cause	Related SCs	Troubleshooting Procedure	Type
SC 833 [0F21]	Self-diagnostic error: I/F error	The controller detects that the BCU is not properly connected.	<ul style="list-style-type: none"> Loose connection Defective controller Defective BCU 		<ol style="list-style-type: none"> Turn the main switch off and on. Check the connection between the BCU and controller. Replace the controller. Replace the BCU. 	CTL
SC 835	Self-diagnosis error: Centronics interface [XXXX]: Detailed error code					
[1102]	Verification error	The controller detects that the loop-back connector is not properly connected.	<ul style="list-style-type: none"> Loose connection Defective loop-back connector Defective Centronics connector Defective controller 		<ol style="list-style-type: none"> Turn the main switch off and on. Check the connection between the Centronics connector and loop-back connector. Reconnect the loop-back connector. Replace the controller. 	CTL
[110C]	DMA verification error	A DMA data abnormality is detected even when the loop-back connector is properly set.				
[1120]	Loop-back connector error	The loop-back connector is not set when starting the detailed self-diagnostics.				
SC 836 [1601]	Self-diagnosis error: Font ROM (standard)	The data in the font ROM (standard ROM-DIMM) is damaged. .	<ul style="list-style-type: none"> Defective standard ROM-DIMM 		<ol style="list-style-type: none"> Turn the main switch off and on. Replace the standard ROM-DIMM. 	CTL
SC 837 [1602]	Self-diagnosis error: Font ROM (option)	The data in the font ROM (optional ROM-DIMM) is damaged.	<ul style="list-style-type: none"> Defective optional ROM-DIMM 		<ol style="list-style-type: none"> Turn the main switch off and on. Replace the optional ROM-DIMM. 	CTL
SC 850	Network interface error	The network is unusable.	<ul style="list-style-type: none"> Defective controller 		<ol style="list-style-type: none"> Turn the main switch off and on. Replace the controller. 	CTL
SC 851	IEEE1394 interface error	The 1394 interface is unusable.	<ul style="list-style-type: none"> Defective IEEE1394 Defective controller. 		<ol style="list-style-type: none"> Turn the main switch off and on. Replace the IEEE1394 interface board. Replace the controller. 	CTL
SC 860	HDD: Initialization error	The controller detects that the hard disk fails.	<ul style="list-style-type: none"> HDD not initialized Defective HDD 		<ol style="list-style-type: none"> Turn the main switch off and on. Reformat the HDD. Replace the HDD. 	CTL

SC No.	Item	Definition	Possible Cause	Related SCs	Troubleshooting Procedure	Type
SC 861	HDD: Reboot error	The HDD does not become ready within 30 seconds after the power is supplied to the HDD.	<ul style="list-style-type: none"> Loose connection Defective cables Defective HDD Defective controller 		<ol style="list-style-type: none"> Turn the main switch off and on. Check the connection between the HDD and controller. Check and replace the cables. Replace the HDD. Replace the controller. 	CTL
SC 863	HDD: Read error	The data stored in the HDD cannot be read correctly.	<ul style="list-style-type: none"> Defective HDD Defective controller 		<ol style="list-style-type: none"> Turn the main switch off and on. Replace the HDD. Replace the controller. 	CTL
SC 864	HDD: CRC error	While reading data from the HDD or storing data in the HDD, data transmission fails.	<ul style="list-style-type: none"> Defective HDD 		<ol style="list-style-type: none"> Turn the main switch off and on. Replace the HDD. 	CTL
SC 865	HDD: Access error	An error is detected while operating the HDD.	<ul style="list-style-type: none"> Defective HDD 		<ol style="list-style-type: none"> Turn the main switch off and on. Replace the HDD. 	CTL
SC 900	Electric counter error	Abnormal data is stored in the counters.	<ul style="list-style-type: none"> Defective NVRAM Defective controller 		<ol style="list-style-type: none"> Turn the main switch off and on. Check the connection between the NVRAM and controller. Replace the NVRAM. Replace the controller. 	CTL
SC 990	Software performance error	The software makes an unexpected operation.	<ul style="list-style-type: none"> Defective software Defective controller Software error 		<ol style="list-style-type: none"> Turn the main switch off and on. Reinstall the controller and/or engine main firmware. See NOTE 1 at the end of the SC table. 	CTL
SC 998	Application start error	No applications start within 60 seconds after the power is turned on.	<ul style="list-style-type: none"> Loose connection of RAM-DIMM, ROM-DIMM Defective controller Software problem 		<ol style="list-style-type: none"> Turn the main switch off and on. Check if the RAM-DIMM and ROM-DIMM are properly connected. Reinstall the controller system firmware. Replace the controller. 	CTL

NOTE 1: If a problem always occurs in a specific condition (for example. printer driver setting, image file), the problem may be caused by a software error. In this case, the following data and information needs to be sent back to your product specialist.

- Symptom / Possible Causes / Action taken
- Summary sheet (SP mode '1 Service', [Print Summary])
- SMC All (SP5-990-002)
- Logging (SP5-990-004)
- Printer driver settings used when the problem occurs
- All data displayed on the screen (SC code, error code, and program address where the problem is logged.)
- Image file which causes the problem, if possible

4.4 ELECTRICAL COMPONENT DEFECTS

4.4.1 SENSORS

Component	CN	Condition	Symptom
LD H.P. sensor	220-B12	Open	SC261
		Shorted	SC260
TD sensor	K:208-A3 Y:208-B10 M:207-A19 C:208-A9	Open	SC370/371/372/373
		Shorted	SC370/371/372/373 or SC374/375/376/377
Transfer belt set sensor	208-B2	Open	SC471
		Shorted	
Transfer belt H.P. sensor	212-2	Open	SC471
		Shorted	
ID sensor	Rear:213-11 Front:213-14	Open	SC385
		Shorted	
Paper end sensor	Tray1:202-A5 Tray2:202-B7 By-pass:207-A15	Open	The Paper End indicator lights even if paper is placed in the paper tray.
		Shorted	The Paper End indicator does not light even if there is no paper in the paper tray.
Paper lift sensor	Tray1:202-A2 Tray2:202-B4	Open	The bottom plate of the paper feed unit is not lifted up.
		Shorted	SC501/502
Relay sensor	202-A8	Open	Paper Jam is detected whenever a print is made.
		Shorted	Paper Jam is detected even if there is no paper.
Vertical transport sensor	202-B10	Open	Paper Jam is detected whenever a print is made.
		Shorted	Paper Jam is detected even if there is no paper.
Registration sensor	207-B2	Open	Paper Jam is detected whenever a print is made.
		Shorted	Paper Jam is detected even if there is no paper.
Fusing exit sensor	210-A11	Open	Paper Jam is detected whenever a print is made.
		Shorted	Paper Jam is detected even if there is no paper.
Paper exit sensor	210-B2	Open	Paper Jam is detected whenever a print is made.
		Shorted	Paper Jam is detected even if there is no paper.
Exit upper limit sensor	210-A6	Open	The paper overflow message is not displayed even when a paper overflow condition exists, causing paper jam.
		Shorted	The paper overflow message is displayed.

The CN numbers are the connector numbers on the BCU.

4.5 BLOWN FUSE CONDITIONS

Fuse	Rating		Symptom when turning on the main switch
	115 V	220 - 240 V	
Power Supply Unit			
FU1	15A/125V	- - -	No response (No power is supplied to the electrical components.)
CB1	- - -	8A/250V	
FU2	10A/125V	5 A/250V	No response (No DC power is supplied to the electrical components.)
FU81	3.15 A/250 V	3.15A/250V	Only 12V DC power is not supplied. SC260 or SC261 may occur. (This fuse is directly soldered on the PSU.)

4.6 LEDS (BCU)

LED	Status	
	Blinking	Stays OFF or ON
LED1 (RED)	The Main CPU functions correctly.	The Main CPU does not function properly.
LED (Green)	The MUSIC CPU functions correctly.	The MUSIC CPU does not function properly.



5. SERVICE TABLES

5.1 SERVICE PROGRAM MODE

⚠ CAUTION

Before accessing the service menu, do the following:

Confirm that there is no print data in the printer buffer (the Data In LED must not be lit or blinking).

If there is some data in the buffer, wait until all data has been printed.

5.1.1 ENABLING AND DISABLING SERVICE PROGRAM MODE

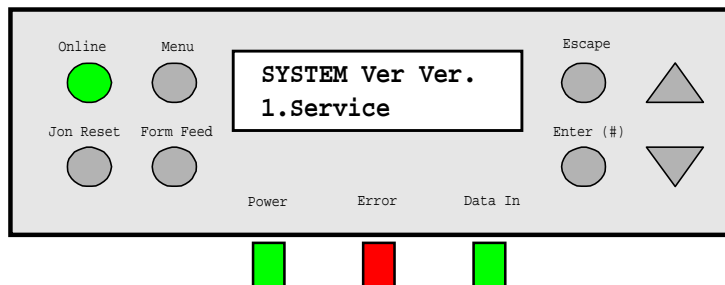

G058D520.WMF

Service
Tables

Entering the Service Mode

There are two ways to enter the service mode.

Method 1: Turn the machine on while pressing the “On Line” key and “Escape” key together until the above message in the illustration appears on the display.

NOTE: If you switch the machine off, any jobs stored on the hard disk using the sample print and protected print features will be deleted.

Check first with the user tools to see if there are any jobs stored with these features

(Menu key - Sample Print, or Protected Print).

Method 2: Press the “Up/Down arrow” keys together for about 5 seconds, then press the “Enter” key.

The above message shown in the illustration appears on the display.

NOTE: The machine automatically goes off line when you enter the service mode.

Accessing the Required Program

Use the “Up/Down arrow” keys to scroll through the menu listing.

- 1. Service Menu: Controller service modes
- 2. Engine Mainte: Engine service modes
- 3: End: Exit service mode

To select an item, press the “Enter” key. Then the sub-menu will appear. Scroll through the sub menu items using the “Up/Down arrow” keys. To go back to a higher level, press the “Escape” key.

Inputting a Value or Setting for a Service Program

Enter the required program mode as explained above. The setting appearing on the display is the current setting.

Select the required setting using the “Up/Down arrow” keys, then press the “Enter” key. The previous value remains if the “Enter” key is not pressed.

Exiting Service Mode

Select “3. End” from the service mode main menu, then press the “Enter” key.

NOTE: To make the following settings effective, you must turn the main switch off and on after exiting service mode.

SP Modes Related to the Engine	SP Modes Related to the Controller
SP2-208-009	SP5-009-001
SP2-213-001	SP5-961-001
SP2-224-001 to 004	
SP5-930-001 to 005	
SP5-994-001 and 002	
SP7-905-007 and 009	

NOTE: If the settings of SP modes 5-993-013 to 015 are changed, these changes will affect the next line position adjustment.

5.2 PRINTER CONTROLLER SERVICE MODE

5.2.1 REMARKS

Display on the Control Panel Screen

Since the maximum number of characters which can be displayed on the control panel screen is limited (14 characters), the description of SP modes displayed on the screen needs to be abbreviated. The following are the major abbreviations used for the SP modes for which the full description is over 14 characters.

Paper Type

N: Normal paper
TH: Thick paper

Color Mode [Color]

[K]: Black in B&W mode
[Y], [M], or [C]: Yellow, Magenta, or Cyan in Full Color mode
[YMC]: Only for Yellow, Magenta, and Cyan
[FC]: Full Color mode
[FC, K], [FC, Y], [FC, M], or [FC, C]: Black, Yellow, Magenta, or Cyan in full color mode

Paper Feed Station

P: Paper tray
B: By-pass table

Fusing Section

H: Heating roller
P: Pressure roller

Print Mode

S: Simplex
D: Duplex

Process Speed

62.5, 125, 185

As shown in the following table, the process speed (mm/s) depends on the print mode (B&W or Color), resolution, and/or type of paper selected. Some SP mode settings depend on the process speed.

Mode	Resolution (dpi)	Line speed (mm/s)	Print speed (ppm)
B/W	600 x 600	185	38
	1,200 x 600		
Color	1,200 x 1,200	125	28
	600 x 600	125	28
	1,200 x 600		
OHP/Thick	1,200 x 1,200	62.5	14
	600 x 600	62.5	10
	1,200 x 600		
	1,200 x 1,200		

Others

The following symbols are used in the SP mode tables.

FA: Factory setting

(Data may be adjusted from the default setting at the factory. Refer to the factory setting sheets enclosed, which is located underneath the jammed paper removal decal.)

DFU: Design / Factory Use only

Do not touch the SP mode in the field.

“P” in the right hand side of the mode number column means that this SP mode relates to the Printer Controller. If “P” is not in the column, this SP mode relates to the Printer Engine.

A sharp (#) to the right hand side of the mode number column means that the main switch must be turned off and on to effect the setting change.

An asterisk (*) to the right hand side of the mode number column means that this mode is stored in the EEPROM (Engine) or NVRAM (Printer Controller). If you do a RAM clear, this SP mode will be reset to the default value.

The settings of each SP mode are explained in the right-hand column of the SP table in the following manner.

[Adjustable range / Default setting / Step] Alphanumeric

NOTE: If “Alphanumeric” is written to the right of the bracket as shown above, the setting of the SP mode is displayed on the screen using alphanumeric characters instead of only numbers. However, the settings in the bracket in the SP mode table are explained by using only the numbers.

5.2.2 SERVICE MODE MENU (“1. SERVICE”)

Mode No. (Class 1 and 2)		Function / [Setting]		
[Bit Switch]				
1	Bit Switch 1	*P	Adjusts bit switch settings. DFU NOTE: Currently the bit switches are not being used. All data has to be set to “0”.	
2	Bit Switch 2			
3	Bit Switch 3			
4	Bit Switch 4			
[Clear Setting]				
1	Clear Setting	P	Initializes settings in the “System” menu of the user mode.	
[Print Summary]				
1	Print Summary	P	Prints the service summary sheet (a summary of all the controller settings).	
[Disp. Version]				
1	Disp. Version	P	Displays the version of the controller firmware.	
[Data Recall]				
1	Factory	*P	Recalls a set of gamma settings. This can be either a) the factory setting, b) the previous setting, or c) the current setting.	
2	Previous			
3	Current			
[Mode Selection]				
1	*1200x1200Photo	P	Selects the printing mode (resolution) for the printer gamma adjustment. When selecting a print mode, an asterisk (*) is displayed in the front of the mode.	
2	600 x 600 Text			
3	1200 x 600 Text			
4	600x600 Photo			
5	1200x600Photo			
[Test Page]				
1	Gradation		Prints the test page to check the color balance before and after the gamma adjustment.	
2	Color Pattern			
[Gamma Adj.]				
1	Black/Cyan/Magenta/Yellow 1	*P	Adjusts the printer gamma for the mode selected in the “Mode Selection” menu. [0 to 255 / 16 / 1/step]	
2	Black/Cyan/Magenta/Yellow 2			[0 to 255 / 32 / 1/step]
3	Black/Cyan/Magenta/Yellow 3			[0 to 255 / 48 / 1/step]
4	Black/Cyan/Magenta/Yellow 4			[0 to 255 / 64 / 1/step]
5	Black/Cyan/Magenta/Yellow 5			[0 to 255 / 80 / 1/step]
6	Black/Cyan/Magenta/Yellow 6			[0 to 255 / 96 / 1/step]
7	Black/Cyan/Magenta/Yellow 7			[0 to 255 / 112 / 1/step]
8	Black/Cyan/Magenta/Yellow 8			[0 to 255 / 128 / 1/step]
9	Black/Cyan/Magenta/Yellow 9			[0 to 255 / 144 / 1/step]
10	Black/Cyan/Magenta/Yellow 10			[0 to 255 / 160 / 1/step]
11	Black/Cyan/Magenta/Yellow 11			[0 to 255 / 176 / 1/step]
12	Black/Cyan/Magenta/Yellow 12			[0 to 255 / 192 / 1/step]
13	Black/Cyan/Magenta/Yellow 13			[0 to 255 / 208 / 1/step]
14	Black/Cyan/Magenta/Yellow 14			[0 to 255 / 224 / 1/step]
15	Black/Cyan/Magenta/Yellow 15			[0 to 255 / 240 / 1/step]
[Data Save]				
1	Data Save	P	Stores the print gamma adjusted with the “Gamma Adj.” menu item as the current setting. Before the machine stores the new ‘current setting’, it moves the data currently stored as the ‘current setting’ to the ‘previous setting’ memory storage location.	

Mode No. (Class 1 and 2)		Function / [Setting]	
[Toner Limit]			
1	Photo	*P	Adjusts the maximum toner amount for image development. [100 to 400 / <u>260</u> / 1 %/step]
2	Text		[100 to 400 / <u>190</u> / 1 %/step]



5.2.3 BIT SWITCH PROGRAMMING

NOTE: Currently, the bit switches are not being used.

1. Enter the SP mode, select "Service Menu", then press [Enter] twice.

```
<Service>
Bit Switch >>
```

2. Select #1, #2, #3, or #4 for the desired bit switch, then press [Enter].
 - [▲] [▼]: Move to the next switch.

```
Bit Switch
Bit switch 1
```

3. Adjust the bit switch using the following keys.
 - [▲] [▼]: Move to the next bit.
 - [Escape]: Exit without saving changes.
 - [Enter]: Exit and save changes.

```
Sw#1  00000000
bit0   _
```

NOTE: The left digit on the display is bit 7 and the right digit is bit 0.



4. Press [Enter] to save changes and exit.

5.3 PRINTER ENGINE SERVICE MODE

5.3.1 SERVICE MODE TABLE ("2. ENGINE")

SP1-XXX (Feed)

1	Mode No. (Class 1, 2, and 3)	Function / [Setting]
001	[Lead Edge Reg.] Leading Edge Registration (Paper Type, [Color], Process Speed), Paper Type -> N: Normal, OHP, TH: Thick	
	1	N [K] 62.5 *
	2	N [K] 125 *
	3	N [K] 185 *
	4	N [FC] 62.5 *
	5	N [FC] 125 *
	6	TH [K] *
	7	TH [FC] *
	8	OHP [K] *
	9	OHP [FC] *
002	[S-to-S Reg.] Side-to-Side Registration	
	1	By-pass Table *
	2	Paper Tray 1 *
	3	Paper Tray 2 *
	4	Paper Tray 3 *
	5	Paper Tray 4 *
003	[Paper Buckle] Paper Buckle (Paper Tray or By-pass, Paper Type, Process Speed), Paper Type: N: Normal, TH: Thick	
	1	P 62.5 *
	2	P 125 *
	3	P 185 *
	4	B N 62.5 *
	5	B N 125 *
	6	B N 185 *
	7	B TH *
004	[Dev. Mt Speed1] Development Drive Motor Speed 1 ([Color], Process Speed, Paper Type), Paper Type -> N: Normal, TH: Thick	
	1	[K] 62.5 N *
	2	[K] 125 *
	3	[K] 185 *
	4	[YMC] 62.5 *
	5	[YMC] 125 *
	6	[YMC] 185 *
7	[K] 62.5 TH *	
005	[Dev. Mt Speed2] Development Drive Motor Speed 2 ([Color], Process Speed, Paper Type), Paper Type -> TH: Thick	
	1	[K] 125 *
	2	[YMC] 125 *
104	[Fusing Cont.] Fusing Control	
	1	Control Method *

1	Mode No. (Class 1, 2, and 3)		Function / [Setting]
104	25	Process Speed	<p>* Selects the power-on default target fusing operation temperature. The target operating fusing temperature depends on the process speed. When the machine is switched on, it starts warming up for the process speed specified in this SP mode.</p> <p>[0 to 4 / <u>4</u> / 1/step] Alphanumeric 0: Color 62.5 mm/s (temperature specified by SP 1-105-8 and 19) 1: Color 125 mm/s (temperature specified by SP 1-105-9 and 20) 2: Thick / OHP (temperature specified by SP 1-105-13 and 24) 3: K 125 mm/s (temperature specified by SP 1-105-4 and 15) 4: K 185 mm/s (temperature specified by SP 1-105-5 and 16)</p>
105	<p>[Fusing Temp.] Fusing Temperature (Heating or Pressure roller: Paper Type, [Color], Simplex/Duplex, Process Speed) Paper Type -> N: Normal, OHP. TH: Thick</p>		
1	H: Ready	*	<p>Sets the heating roller temperature for the printing ready condition. After the main switch has been turned on, the machine enters the print ready condition when the heating roller temperature reaches the temperature specified in this SP mode. When the machine is in the recovery mode from the energy saver or auto off mode, the machine becomes ready when both heating and pressure roller temperatures reach the specified temperature. Ready temperature = (Target temperature specified in SP1-104-25 or 105-3 to 24) –  Temperature specified in this SP mode. [0 to 100 / <u>10</u> / 1°C/step]</p>
2	P: Ready	*	<p>Sets the pressure roller temperature for the printing ready condition. Ready temperature = (Target temperature specified in SP1-104-25 or 105-3 to 24) –  Temperature specified in this SP mode [0 to 100 / <u>20</u> / 1°C/step]</p>
<p>The following SPs set the target operating temperatures of the heating and pressure rollers in various modes.</p>			
3	H:N [K] S 62.5	*	[100 to 200 / <u>140</u> / 5°C/step]
4	H:N [K] S 125	*	[100 to 200 / <u>165</u> / 5°C/step]
5	H:N [K] S 185	*	[100 to 200 / <u>175</u> / 5°C/step]
6	H:N [K] D 125	*	[100 to 200 / <u>155</u> / 5°C/step]
7	H:N [K] D 185	*	[100 to 200 / <u>165</u> / 5°C/step]
8	H:N[FC] S 62.5	*	[100 to 200 / <u>140</u> / 5°C/step]
9	H:N[FC] S 125	*	[100 to 200 / <u>170</u> / 5°C/step]
10	H:N[FC] D 62.5	*	[100 to 200 / <u>135</u> / 5°C/step]
11	H:N[FC] D 125	*	[100 to 200 / <u>160</u> / 5°C/step]
12	H:OHP [K]	*	[100 to 200 / <u>170</u> / 5°C/step]
13	H:OHP [FC]	*	[100 to 200 / <u>170</u> / 5°C/step]

1	Mode No. (Class 1, 2, and 3)		Function / [Setting]
105	14	P:N [K] S 62.5	* [0 to 200 / <u>120</u> / 5°C/step]
	15	P:N [K] S 125	* [0 to 200 / <u>145</u> / 5°C/step]
	16	P:N [K] S 185	* [0 to 200 / <u>155</u> / 5°C/step]
	17	P:N [K] D 125	* [0 to 200 / <u>135</u> / 5°C/step]
	18	P:N [K] D 185	* [0 to 200 / <u>145</u> / 5°C/step]
	19	P:N[FC] S 62.5	* [0 to 200 / <u>120</u> / 5°C/step]
	20	P:N[FC] S 125	* [0 to 200 / <u>150</u> / 5°C/step]
	21	P:N[FC] D 62.5	* [0 to 200 / <u>115</u> / 5°C/step]
	22	P:N[FC] D 125	* [0 to 200 / <u>140</u> / 5°C/step]
	23	P:OHP [K]	* [0 to 200 / <u>150</u> / 5°C/step]
	24	P:OHP [FC]	* [0 to 200 / <u>150</u> / 5°C/step]
	25	H:TH [K]	* [0 to 200 / <u>175</u> / 5°C/step]
	26	H:TH [FC]	* [0 to 200 / <u>175</u> / 5°C/step]
	27	P:TH [K]	* [0 to 200 / <u>155</u> / 5°C/step]
28	P:TH [FC]	* [0 to 200 / <u>155</u> / 5°C/step]	
106	[Temp. Display] Fusing Temperature Display (Heating or Pressure)		
	1	H Roller	Displays the current temperature of the heating and pressure rollers.
	2	P Roller	
902	[Paper Size] Tray Paper Size		
	1	Tray 1 A4/LT	* Specifies the paper size for tray 1. [0 or 1 / <u>0</u> / -] Alphanumeric 0: A4 sideways, 1: LT sideways Tray 1 can only use these two sizes. US: 1 FA
	2	Tray 2 B4/LG	* Specifies the paper size for tray 2. [0 or 1 / <u>0</u> / -] Alphanumeric 0: B4 lengthwise, 1: LG lengthwise This specifies which size is detected for a sensor output of 1101 (see section 6 for details). US: 1 FA
	3	Tray 2 A4/LT	* Specifies the paper size for tray 2. [0 or 1 / <u>0</u> / -] Alphanumeric 0: A4 lengthwise, 1: LT lengthwise This specifies which size is detected for a sensor output of 0110 (see section 6 for details). US: 1 FA
	4	Tray 2 B5/LT	* Specifies the paper size for tray 2. [0 or 1 / <u>0</u> / -] Alphanumeric 0: LT, 1: B5 lengthwise This specifies which size is detected for a sensor output of 1011 (see section 6 for details).
910	[Idling Time] (Fusing Idling Time)		
	1	Idling Time	* Specifies the timer for deciding whether to do fusing idling when receiving a print command. When receiving a new job within the time specified in this SP mode after the last job is completed, fusing idling is not done because the fusing section was already warmed up during the last job. [0 to 180 / <u>1</u> / 1 minute/step] DFU

Service
Tables

1	Mode No. (Class 1, 2, and 3)		Function / [Setting]
913	[Temp. Cor. 1] Fusing Temperature Correction (Correction Timing)		
	1	Sheet Setting	* Specifies the number of sheets to determine whether or not to apply the fusing temperature correction. During a multi print job, the fusing temperature tends to slightly overshoot around the 10th sheet and then stabilize. Temperature overshooting may cause the glossiness to increase. To minimize the overshooting, both fusing and pressure roller temperatures are decreased by the amount specified in SP1-914 at the number of sheets specified in this SP mode, until the end of the job. [1 to 60 / <u>10</u> / 1 sheet/step]
914	[Temp. Cor. 2] Fusing Temperature Correction (Temperature Setting)		
	1	Heating	* Specifies the temperature to be subtracted from the targeted temperatures specified in SP1-105-3 to-24. [0 to 30 / <u>10</u> / 5°C /step]
	2	Pressure	
915	[Stand-by Time]		
	1	Job Receiving	* Specifies the time to shift the machine into the stand-by mode when not receiving a print start command after receiving a print preparation command. [0 to 180 / <u>60</u> / 10 seconds/step] 0: The machine does not shift to the stand-by mode.
	2	Job End	* Specifies the time to shift the machine into the stand-by mode after the last job is completed. [0 to 180 / <u>60</u> / 10 seconds/step] 0: The machine does not shift to the stand-by mode.
996	[OHP/TH Fusing] OHP/Thick Paper Fusing Temperature Correction (Heating or Pressure Roller)		
	Specifies the temperature for starting a print job. The fusing section is already warmed up when the last print job was completed. If prints are made on OHP or thick paper at this time, the fusing temperature tends to be higher than the target, causing exit roller marks or a paper jam in the fusing section. To prevent this, the print job will not start if the heating and pressure roller temperatures are higher than the following: (Target temperature specified by SP1-105-12, -13, -23, -24) - (Temperature specified by this SP mode (default: 5°C for heating roller, 10°C for pressure roller))		
	4	H:Print Temp	* [1 to 30 / <u>5</u> / 1°C /step]
	5	P:Print Temp	* [1 to 30 / <u>10</u> / 1°C /step]

SP2-XXX (Drum)

2	Mode No. (Class 1, 2, and 3)		Function / [Setting]
001	[Charge Bias] Charge Roller Bias (DC or AC component: [Color], Process Speed) U: Upper, L: Lower		
	1	DC:[K] 62.5	*
	2	DC:[K] 125	*
	3	DC:[K] 185	*
	4	DC:[Y] 62.5	*
	5	DC:[Y] 125	*
	6	DC:[M] 62.5	*
	7	DC:[M] 125	*
	8	DC:[C] 62.5	*
	9	DC:[C] 125	*
	10	AC U Limit [K]	* Sets the upper limit of the AC component adjustable range for black. During machine initialization and process control self-check, the AC component of the charge roller bias is automatically adjusted within the range specified by SP2-001-010 and 011. [0 to 255 / 103 / 1/step] DFU
	11	AC L Limit [K]	* Sets the lower limit of the AC component adjustable range for black. [0 to 255 / 97 / 1/step] DFU
	12	AC:[K] 62.5	<ul style="list-style-type: none"> • Displays the AC component of the charge roller bias adjusted during machine initialization or process control self-check. • Sets AC bias in the various print modes for test purposes. <p>If the optimum AC bias cannot be selected because of the upper and lower limits (SP2-001-10 and 11 for K, SP 2-001-21 and 22 for YMC), this may cause white spots on images and black spots on background. (In particular, spots may appear if the room temperature is very low.) Check the printouts after changing the AC bias with these SP modes (SP2-001-12 to 20) and exiting SP mode. If increasing or decreasing the AC bias for relevant color solves the spot problem, shift the AC upper and lower limits (SP2-001-10 and 11 for K, SP 2-001-21 and 22 for YMC) by the value increased or decreased during the test.</p> <p>NOTE: The AC upper and lower limits have been optimized by the manufacturer; therefore, these settings should not be adjusted in the field.</p> [0 to 255 / 71 / 1/step] DFU
	13	AC:[K] 125	[0 to 255 / 71 / 1/step] DFU
	14	AC:[K] 185	[0 to 255 / 148 / 1/step] DFU
	15	AC:[Y] 62.5	[0 to 255 / 71 / 1/step] DFU
	16	AC:[Y] 125	[0 to 255 / 71 / 1/step] DFU
	17	AC:[M] 62.5	[0 to 255 / 71 / 1/step] DFU
	18	AC:[M] 125	[0 to 255 / 71 / 1/step] DFU
	19	AC:[C] 62.5	[0 to 255 / 71 / 1/step] DFU

Service Tables

2	Mode No. (Class 1, 2, and 3)			Function / [Setting]
001	20	AC:[C] 125		[0 to 255 / <u>71</u> / 1/step] DFU
	21	AC U Limit[FC]	*	Sets the upper limit of the AC component adjustable range for color. During machine initialization and process control self-check, the AC component of the charge roller bias is automatically adjusted within the range specified in the SP2-001-021 and 022. [0 to 255 / <u>90</u> / 1/step] DFU
	22	AC L Limit[FC]	*	Sets the lower limit of the AC component adjustable range for color. [0 to 255 / <u>84</u> / 1/step] DFU
103	[LD Control] LD Power Control ([Color Mode, Color], Process Speed, K or C olor mode) P: Power, M: Magnification			
	Adjusts the laser power by changing the current applied to LD. Laser power is automatically adjusted during process control; therefore, adjusting these data has no effect while Process Control (SP3-125 Default : ON) is activated. After deactivating Process Control with SP3-125, the values in these SP modes are used for printing.			
	1	P0:[FC,K] 62.5	*	[0 to 1023 / <u>754</u> / 1/step] DFU
	2	P0:[FC,K] 125	*	[0 to 1023 / <u>718</u> / 1/step] DFU
	4	P0:[FC,Y] 62.5	*	[0 to 1023 / <u>754</u> / 1/step] DFU
	5	P0:[FC,Y] 125	*	[0 to 1023 / <u>718</u> / 1/step] DFU
	7	P0:[FC,M] 62.5	*	[0 to 1023 / <u>754</u> / 1/step] DFU
	8	P0:[FC,M] 125	*	[0 to 1023 / <u>718</u> / 1/step] DFU
	10	P0:[FC,C] 62.5	*	[0 to 1023 / <u>754</u> / 1/step] DFU
	11	P0:[FC,C] 125	*	[0 to 1023 / <u>718</u> / 1/step] DFU
	13	P0:[K,K] 62.5	*	[0 to 1023 / <u>754</u> / 1/step] DFU
	14	P0:[K,K] 125	*	[0 to 1023 / <u>754</u> / 1/step] DFU
	15	P0:[K,K] 185	*	[0 to 1023 / <u>675</u> / 1/step] DFU
	25	P1:[K,K] 62.5	*	[0 to 1023 / <u>754</u> / 1/step] DFU
	26	P1:[K,K] 125	*	[0 to 1023 / <u>754</u> / 1/step] DFU
	27	P1:[K,K] 185	*	[0 to 1023 / <u>675</u> / 1/step] DFU
	Main Scan Magnification ([Color], Laser Exposure Frequency)			
	55	M:[K] 64.3MHz	*	Displays the result of the latest line position adjustment. Changing this affects the main scan magnification; however, this will be automatically corrected at the next line position adjustment. If a fine adjustment is required, it can be done with SP5-993-013 to 015 (this affects the way that the adjustment is done, and will be effective from the next line position adjustment). [0 to 280 / <u>140</u> / 1 dot/step] 1 dot = 20μ DFU NOTE: If the line position adjustment does not work properly, the line position can be adjusted manually with this SP mode as a temporary measure. In this case, the line position adjustment needs to be disabled with SP5-993-001.
	56	M:[Y] 64.3MHz	*	
	57	M:[M] 64.3MHz	*	
58	M:[C] 64.3MHz	*		
59	M:[K] 47.6MHz	*		
109	[LD Beam Pitch] LD Beam Pitch			
	Sets the beam pitch for black in 1200 dpi or 600 dpi mode. NOTE: After replacing the laser optics housing unit, the data printed on the decal attached to the new unit must be input with this SP mode.			
	2	Pitch 1200	*	[0 to 255 / <u>50</u> / 50 pulse/step] FA
	3	Pitch 600	*	[0 to 255 / <u>42</u> / 50 pulse/step] FA
5	Display 1200		[0 to 255 / - / 1 pulse/step]	

2	Mode No. (Class 1, 2, and 3)			Function / [Setting]
109	6	Display 600		[0 to 255 / - / 1 pulse/step]
112	[Polygon OFF 1] Polygon Mirror Motor OFF Timing			
	1	Warming-up	*	The polygon mirror motor turns off if the machine receives no print start command for the time specified in this SP mode after receiving the print preparation command. [0 to 60 / <u>10</u> / 1 second/step] 0: Not turned off except for Energy Saver mode
	2	Job End	*	The polygon mirror motor turns off if the machine receives no print job for the time specified in this SP mode after the previous job was completed. [0 to 60 / <u>1</u> / 1 second/step] 0: Not turned off except for Energy Saver mode
113	[Polygon OFF 2] Polygon Mirror Motor OFF			
	1	Polygon OFF 2		The polygon mirror motor does not turn on until the printer enters the ready condition even after receiving the print start command. [0 or 1 / <u>1</u> / 1 /step] 0: Enable, 1: Disable NOTE: When a user complains about high frequency noise, enabling this mode can minimize the noise.
201	[Dev. Bias] Development Bias ([Color], Process Speed)			
	1	[K] 62.5	*	Adjusts the development bias.
	2	[K] 125	*	Development bias is automatically adjusted during process control; therefore, adjusting these settings has no effect while Process Control (SP3-125
	3	[K] 185	*	Default: ON) is activated.
	4	[Y] 62.5	*	After deactivating Process Control with SP3-125,
	5	[Y] 125	*	the values in these SP modes are used for
	6	[M] 62.5	*	printing.
	7	[M] 125	*	[200 to 800 / <u>500</u> / 10 V/step] DFU
	8	[C] 62.5	*	
	9	[C] 125	*	
207	[Forced Toner] Forced Toner Supply ([Color])			
	1	[K]	*	Forces toner to be supplied to the development
	2	[Y]	*	unit for the number of times specified by this SP
	3	[M]	*	mode.
	4	[C]	*	1 time: The toner supply clutch turns on for 0.7 s
				and off for 1.3 s.
				[0 to 3 / <u>2</u> / 1/step]
208	[Toner Mode] Toner Supply Method ([Color])			
	1	[K]	*	Selects the toner supply method.
	2	[Y]	*	[0 to 2 / <u>1</u> / 1/step] Alphanumeric
	3	[M]	*	0: Fixed supply (with the supply rates stored with
	4	[C]	*	SP2-208-5 to 8)
				1: Fuzzy control supply
				2: Proportional control supply (using the Vref
				values stored with SP2-224-5 to 8)
	5	Fixed Rate [K]	*	Sets the toner supply rate used when the toner
	6	Fixed Rate [Y]	*	supply method (SP2-208-1 to 4) is set to '0' (fixed
	7	Fixed Rate [M]	*	supply mode).
	8	Fixed Rate [C]	*	[0 to 100 / <u>5</u> / 1%/step]

Service Tables

2	Mode No. (Class 1, 2, and 3)			Function / [Setting]
208	9	Upper Limit	* #	<p>Specifies the maximum possible toner supply, expressed as a percentage of the maximum amount of toner that can possibly be supplied for a sheet of paper.</p> <p>If too much toner is supplied to the development unit especially for black or in the low humidity condition, this may cause dirty background due to insufficient agitation. This SP mode limits the maximum possible toner supply for black and only in the low humidity condition for color.</p> <p>[20 to 70 / <u>42</u> / 1 %/step] DFU</p> <p>NOTE: The main switch must be turned off and on to effect the setting change.</p>
210	[Toner Counter] Toner Supply Counter ([Color])			<p>Displays the total time that the toner supply clutch has been on.</p> <p>This data is stored in the memory chip on each toner cartridge.</p> <p>[0 to 5000 / - / 1 second/step]</p>
	5	[K]	*	
	6	[Y]	*	
	7	[M]	*	
	8	[C]	*	
212	[Toner Near/End] Toner Near End / End Detection Threshold ([Color])			<p>When the amount of toner amount left in the cartridge becomes less than this value, the machine starts monitoring the Vt values for toner near end detection.</p> <p>[0 to 1000 / <u>100</u> / 10 g/step]</p> <p>Specifies the threshold for toner near-end detection.</p> <p>The machine detects toner near-end when the following happens 10 times consecutively.</p> <p>$V_t > V_{ref} + \text{Threshold}$</p> <p>[0 to 50 / <u>4</u> / 0.1 V/step]</p> <p>Specifies the threshold for toner end detection.</p> <p>The machine detects toner end when the following happens 10 times consecutively. Then, the machine stops printing, even during a print job.</p> <p>$V_t > V_{ref} + \text{Threshold}$</p> <p>[0 to 50 / <u>8</u> / 0.1 V/step]</p> <p>Specifies the number of sheets with full image coverage that can be printed after toner near-end has been detected.</p> <p>When near-end is detected, the pixels in the images are counted. The machine detects toner end when the following happens, and the machine stops printing even during a print job.</p> <p>$\text{Pixel count} = 5 \text{ A4/LT sheets with full image coverage}$</p> <p>[0 to 255 / <u>5</u> / 1 sheet/step]</p> <p>NOTE: The setting of SP2-212-11 has priority for deciding when to stop printing.</p>
	1	Start [K]	*	
	2	Start [YMC]	*	<p>When the amount of toner amount left in the cartridge becomes less than this value, the machine starts monitoring the Vt values for toner near end detection.</p> <p>[0 to 1000 / <u>100</u> / 10 g/step]</p>
	5	Near [K]	*	
	6	Near [YMC]	*	<p>Specifies the threshold for toner near-end detection.</p> <p>The machine detects toner near-end when the following happens 10 times consecutively.</p> <p>$V_t > V_{ref} + \text{Threshold}$</p> <p>[0 to 50 / <u>4</u> / 0.1 V/step]</p>
	7	End [K]	*	
	8	End [YMC]	*	<p>Specifies the threshold for toner end detection.</p> <p>The machine detects toner end when the following happens 10 times consecutively. Then, the machine stops printing, even during a print job.</p> <p>$V_t > V_{ref} + \text{Threshold}$</p> <p>[0 to 50 / <u>8</u> / 0.1 V/step]</p>
	9	Pixel [K]	*	
	10	Pixel [YMC]	*	<p>Specifies the number of sheets with full image coverage that can be printed after toner near-end has been detected.</p> <p>When near-end is detected, the pixels in the images are counted. The machine detects toner end when the following happens, and the machine stops printing even during a print job.</p> <p>$\text{Pixel count} = 5 \text{ A4/LT sheets with full image coverage}$</p> <p>[0 to 255 / <u>5</u> / 1 sheet/step]</p> <p>NOTE: The setting of SP2-212-11 has priority for deciding when to stop printing.</p>

2	Mode No. (Class 1, 2, and 3)			Function / [Setting]
212	11	Min. Print	*	Specifies the minimum number of sheets that can be printed after toner near-end has been detected. However, when the following happens 10 consecutive times, the machine stops printing even during a print job or if this guaranteed minimum has not been met. $\underline{Vt} > \text{Current Vref value} + 1.2V \text{ or } \underline{Vt} > 4.8V$ [0 to 50 / <u>10</u> / 1 sheet/step]
213	[T End ON/OFF] Toner End Detection ON/OFF			
	1	T END ON/OFF	* #	Enables or disables toner near-end and end detection (if disabled, the toner supply clutch on time is still counted). [0 or 1 / <u>1</u> / -] Alphanumeric, DFU 0: Disabled, 1 Enabled NOTE: The main switch must be turned off and on to effect the setting change.
223	[TD Vcnt] TD Sensor Vcnt Control			
	1	Initialization	*	Enables or disables the Vcnt Auto Adjustment when detecting a new development unit. When the machine detects a new development unit, developer initialization automatically starts. During the developer initialization, Vcnt is automatically adjusted so that Vt is within $3.0 \pm 0.1V$. [0 or 1 / <u>1</u> / -] Alphanumeric, DFU 0: Disabled 1: Enabled
	2	Humidity	*	Enables or disables the Humidity Auto Correction. This corrects the Vcnt value for the current humidity. This correction is applied to both the Vcnt values automatically adjusted during developer initialization and manually adjusted with SP2-224-1 to 4. If this correction does not work well under certain environmental conditions or due to a defective humidity sensor, deactivate the Humidity Auto Correction and adjust the Vcnt value in SP2-224-1 to 4 (by trial and error). [0 or 1 / <u>1</u> / -] Alphanumeric 0: Disabled 1: Enabled
	3	Toner Fill Up	*	Activates or deactivates the Toner Fill Up mode, which fills up the toner supply tube with toner during developer initialization. This function is required only at machine installation. Although the default is "0", the factory setting is "1". After toner fill-up occurs during machine installation, the setting is changed to "0" automatically. [0 or 1 / <u>0</u> / -] Alphanumeric, DFU 0: Deactivate 1: Activate

Service Tables

2	Mode No. (Class 1, 2, and 3)		Function / [Setting]
224	[Vcnt / Vref] Vcnt / Vref ([Color])		
Adjusts the Vcnt value manually. The value in this SP mode is effective until after the next process control self-check. To always use this value for some reason, select proportional control supply mode with SP2-208-1 to 4.			
	1 Vcnt [K]	*	[0 to 220 / <u>100</u> / 0.1 V/step]
	2 Vcnt [Y]	#	NOTE: The main switch must be turned off and on to effect the setting change.
	3 Vcnt [M]		
	4 Vcnt [C]		
Adjusts the Vref value manually. The value in this SP mode is effective until the next process control self-check. To always use this value for some reason, select proportional control supply mode with SP2-208-1 to 4.			
	5 Vref [K]	*	[0 to 50 / <u>28</u> / 0.1 V/step]
	6 Vref [Y]	*	
	7 Vref [M]	*	
	8 Vref [C]	*	
301	[Transfer Cur.] Transfer Current ([Color Mode, Color], Paper Tray or By-pass, Simplex or Duplex, Process Speed) Paper Type -> TH: Thick Paper, SP: Special Paper		
Adjusts the transfer current for each color and each print mode. NOTE: If the transfer current is increased too much, image offset may occur especially in halftone areas.			
	1 [K]P S 125	*	[5 to 50 / <u>6</u> / 1 μA/step]
	2 [K]P S 185	*	[5 to 50 / <u>18</u> / 1 μA/step]
	3 [K]P D 125	*	[5 to 50 / <u>12</u> / 1 μA/step]
	4 [K]P D 185	*	[5 to 50 / <u>18</u> / 1 μA/step]
	5 [K]B S 62.5	*	[5 to 50 / <u>6</u> / 1 μA/step]
	6 [K]B S 125	*	[5 to 50 / <u>12</u> / 1 μA/step]
	7 [K]B S 185	*	[5 to 50 / <u>18</u> / 1 μA/step]
	8 [FC,K]P S 62.5	*	[5 to 50 / <u>6</u> / 1 μA/step]
	9 [FC,K]P S 125	*	[5 to 50 / <u>12</u> / 1 μA/step]
	10 [FC,Y]P S 62.5	*	[5 to 50 / <u>5</u> / 1 μA/step]
	11 [FC,Y]P S 125	*	[5 to 50 / <u>11</u> / 1 μA/step]
	12 [FC,M]P S 62.5	*	[5 to 50 / <u>5</u> / 1 μA/step]
	13 [FC,M]P S 125	*	[5 to 50 / <u>10</u> / 1 μA/step]
	14 [FC,C]P S 62.5	*	[5 to 50 / <u>5</u> / 1 μA/step]
	15 [FC,C]P S 125	*	[5 to 50 / <u>11</u> / 1 μA/step]
	16 [FC,K]P D 62.5	*	[5 to 50 / <u>6</u> / 1 μA/step]
	17 [FC,K]P D 125	*	[5 to 50 / <u>12</u> / 1 μA/step]
	18 [FC,Y]P D 62.5	*	[5 to 50 / <u>5</u> / 1 μA/step]
	19 [FC,Y]P D 125	*	[5 to 50 / <u>11</u> / 1 μA/step]
	20 [FC,M]P D 62.5	*	[5 to 50 / <u>4</u> / 1 μA/step]
	21 [FC,M]P D 125	*	[5 to 50 / <u>9</u> / 1 μA/step]
	22 [FC,C]P D 62.5	*	[5 to 50 / <u>5</u> / 1 μA/step]
	23 [FC,C]P D 125	*	[5 to 50 / <u>10</u> / 1 μA/step]
	24 [FC,K]B S 62.5	*	[5 to 50 / <u>6</u> / 1 μA/step]
	25 [FC,K]B S 125	*	[5 to 50 / <u>12</u> / 1 μA/step]
	26 [FC,Y]B S 62.5	*	[5 to 50 / <u>5</u> / 1 μA/step]
	27 [FC,Y]B S 125	*	[5 to 50 / <u>11</u> / 1 μA/step]
	28 [FC,M]B S 62.5	*	[5 to 50 / <u>5</u> / 1 μA/step]
	29 [FC,M]B S 125	*	[5 to 50 / <u>10</u> / 1 μA/step]

2	Mode No. (Class 1, 2, and 3)			Function / [Setting]
301	30	[FC,C]B S 625	*	[5 to 50 / <u>5</u> / 1 μA/step]
	31	[FC,C]B S 125	*	[5 to 50 / <u>11</u> / 1 μA/step]
	32	[K]OHP 62.5	*	[0 to 50 / <u>6</u> / 1 μA/step]
	33	[FC,K]OHP 62.5	*	[0 to 50 / <u>15</u> / 1 μA/step]
	34	[FC,Y]OHP 62.5	*	[0 to 50 / <u>12</u> / 1 μA/step]
	35	[FC,M]OHP 62.5	*	[0 to 50 / <u>6</u> / 1 μA/step]
	36	[FC,C]OHP 62.5	*	[0 to 50 / <u>12</u> / 1 μA/step]
	37	[K]TH 62.5	*	[0 to 50 / <u>6</u> / 1 μA/step]
	38	[FC,K]TH 62.5	*	[0 to 50 / <u>5</u> / 1 μA/step]
	39	[FC,Y]TH 62.5	*	[0 to 50 / <u>5</u> / 1 μA/step]
	40	[FC,M]TH 62.5	*	[0 to 50 / <u>5</u> / 1 μA/step]
	41	[FC,C]TH 62.5	*	[0 to 50 / <u>5</u> / 1 μA/step]
	42	[K]SP 62.5	*	[0 to 50 / <u>15</u> / 1 μA/step]
	43	[K]SP 125	*	[0 to 50 / <u>15</u> / 1 μA/step]
	44	[K]SP 185	*	[0 to 50 / <u>15</u> / 1 μA/step]
	45	[FC,K]SP 62.5	*	[0 to 50 / <u>15</u> / 1 μA/step]
	46	[FC,Y]SP 62.5	*	[0 to 50 / <u>15</u> / 1 μA/step]
	47	[FC,M]SP 62.5	*	[0 to 50 / <u>15</u> / 1 μA/step]
	48	[FC,C]SP 62.5	*	[0 to 50 / <u>15</u> / 1 μA/step]
	49	[FC,K]SP 125	*	[0 to 50 / <u>15</u> / 1 μA/step]
	50	[FC,Y]SP 125	*	[0 to 50 / <u>15</u> / 1 μA/step]
	51	[FC,M]SP 125	*	[0 to 50 / <u>15</u> / 1 μA/step]
	52	[FC,C]SP 125	*	[0 to 50 / <u>15</u> / 1 μA/step]
	53	[FC,K]SP 185	*	[0 to 50 / <u>15</u> / 1 μA/step]
	54	[FC,Y]SP 185	*	[0 to 50 / <u>15</u> / 1 μA/step]
	55	[FC,M]SP 185	*	[0 to 50 / <u>15</u> / 1 μA/step]
	56	[FC,C]SP 185	*	[0 to 50 / <u>15</u> / 1 μA/step]
309	<p>[Cur.Paper Size] Transfer Current - Paper Size Correction (Paper Tray or By-pass)</p> <p>Corrects the transfer current for paper size. When small paper is used for printing, the transfer current flows to the drum at the non image areas where the transfer belt touches the OPC drum. This may cause an abnormal image due to insufficient current at the image areas. To increase the current by 1.5 times, set the SP mode to "15". NOTE: Increase only when an abnormal image (insufficient image transfer) occurs on a small paper size. However, increasing the current too much may cause image offset.</p>			
	1	P LT SEF	*	[10 to 40 / <u>12</u> / 0.1/step]
	2	P Post Card	*	[10 to 40 / <u>40</u> / 0.1/step]
	3	B LT SEF	*	[10 to 40 / <u>12</u> / 0.1/step]
	4	B Post Card	*	[10 to 40 / <u>40</u> / 0.1/step]
801	<p>[PA Roller Cur.] Paper Attraction Roller Current ([Color], Simplex or Duplex, Process Speed): Current Adjustment (Paper or By-pass): Paper Size Correction</p>			

Service Tables



2	Mode No. (Class 1, 2, and 3)	Function / [Setting]													
801	<p>Adjusts the paper attraction roller current for black-and-white mode. If paper misfeeds occur at the transfer unit in black-and-white mode, check and/or adjust the paper attraction roller current.</p> <p>NOTE: The black development section is a long way from the paper attraction roller. If the current for black-and-white mode is reduced too much, the transfer belt may not attract the paper properly, causing a paper jam. If the current is increased too much (paper attraction roller current > transfer current), image offset may occur in halftone areas or other image problems may occur (e.g. toner scattering on the image), especially if humidity is low.</p> <p>When adjusting the current with this SP mode, the value should be lower than the transfer current.</p>	<table border="1"> <tr> <td data-bbox="756 651 836 685">1</td> <td data-bbox="836 651 1070 685">[K] S 62.5</td> <td data-bbox="1070 651 1150 685">*</td> <td data-bbox="1150 651 1372 685">[0 to 50 / <u>5</u> / 1 μA/step]</td> </tr> <tr> <td data-bbox="756 685 836 719">2</td> <td data-bbox="836 685 1070 719">[K] S 125</td> <td data-bbox="1070 685 1150 719">*</td> <td data-bbox="1150 685 1372 719">[0 to 50 / <u>10</u> / 1 μA/step]</td> </tr> <tr> <td data-bbox="756 719 836 752">3</td> <td data-bbox="836 719 1070 752">[K] S 185</td> <td data-bbox="1070 719 1150 752">*</td> <td data-bbox="1150 719 1372 752">[0 to 50 / <u>15</u> / 1 μA/step]</td> </tr> </table>	1	[K] S 62.5	*	[0 to 50 / <u>5</u> / 1 μ A/step]	2	[K] S 125	*	[0 to 50 / <u>10</u> / 1 μ A/step]	3	[K] S 185	*	[0 to 50 / <u>15</u> / 1 μ A/step]	<p>Adjusts the paper attraction roller current for color printing. If paper misfeeds occur at the transfer unit in color mode, check and/or adjust the paper attraction roller current.</p> <p>NOTE: The magenta development section is close to the paper attraction roller. Decreasing the current may not cause paper misfeed. If the current is increased too much, the following image problems may occur depending on the humidity.</p> <p><u>High humidity:</u> Insufficient image transfer in magenta due to current flow to the magenta OPC drum</p> <p><u>Low humidity:</u> Offset image in magenta halftone areas due to paper charged positive too much</p> <p>When adjusting the current with this SP mode, the value should be lower than transfer current.</p>
1	[K] S 62.5	*	[0 to 50 / <u>5</u> / 1 μ A/step]												
2	[K] S 125	*	[0 to 50 / <u>10</u> / 1 μ A/step]												
3	[K] S 185	*	[0 to 50 / <u>15</u> / 1 μ A/step]												
6	[FC] S 62.5	*	[0 to 50 / <u>5</u> / 1 μ A/step]												
7	[FC] S 125	*	[0 to 50 / <u>10</u> / 1 μ A/step]												
8	[FC] D 62.5	*	[0 to 50 / <u>2</u> / 1 μ A/step]												
9	[FC] D 125	*	[0 to 50 / <u>5</u> / 1 μ A/step]												
10	P LT SEF	*	[10 to 30 / <u>15</u> / 0.1/step]												
11	P Post Card	*	[10 to 30 / <u>20</u> / 0.1/step]												
12	B LT SEF	*	[10 to 30 / <u>15</u> / 0.1/step]												
13	B Post Card	*	[10 to 30 / <u>20</u> / 0.1/step]												
908	<p>[Mirror Motor] Mirror Positioning Motor ([Color])</p> <p>Displays the result of the latest line position adjustment. Changing this affects the mirror position, which corrects the optically skewed image; however, this will be automatically corrected at the next line position adjustment.</p> <p>NOTE: If the line position adjustment does not work properly, the line position can be adjusted manually with this SP mode as a temporary measure. In this case, the line position adjustment needs to be disabled with SP5-993-001.</p>														
2	[C]	*	[-128 to 127 / <u>0</u> / 1 pulse/step] DFU												
3	[M]	*													
4	[Y]	*													



2	Mode No. (Class 1, 2, and 3)	Function / [Setting]																																									
909	[Main-scan Reg.] Main-scan Registration ([Color])	<p>Displays the result of the latest line position adjustment. Changing this affects the main scan registration; however, this will be automatically corrected at the next line position adjustment. If a fine adjustment is required, it can be done with SP5-993-010 to 012 (this affects the way that the adjustment is done, and will be effective from the next line position adjustment).</p> <p>NOTE: If the line position adjustment does not work properly, the line position can be adjusted manually with this SP mode as a temporary measure. In this case, the line position adjustment needs to be disabled with SP5-993-001. 1 dot = 20μ</p> <table border="1" data-bbox="277 595 756 719"> <tr> <td>1</td> <td>[Y]</td> <td>*</td> <td rowspan="4">[-255 to 255 / 0 / 1 dot/step] DFU</td> </tr> <tr> <td>2</td> <td>[M]</td> <td>*</td> </tr> <tr> <td>3</td> <td>[C]</td> <td>*</td> </tr> <tr> <td>4</td> <td>[K]</td> <td>*</td> </tr> </table>		1	[Y]	*	[-255 to 255 / 0 / 1 dot/step] DFU	2	[M]	*	3	[C]	*	4	[K]	*																											
1	[Y]	*	[-255 to 255 / 0 / 1 dot/step] DFU																																								
2	[M]	*																																									
3	[C]	*																																									
4	[K]	*																																									
916	[Sub-scan Reg.] Sub-scan Registration ([Color Mode, Color], Resolution)	<p>Displays the result of the latest line position adjustment. Changing this affects the sub scan registration; however, this will be automatically corrected at the next line position adjustment. If a fine adjustment is required, it can be done with SP5-993-016 to 021 (this affects the way that the adjustment is done, and will be effective from the next line position adjustment).</p> <p>NOTE: If the line position adjustment does not work properly, the line position can be adjusted manually with this SP mode as a temporary measure. In this case, the line position adjustment needs to be disabled with SP5-993-001. 600 dpi: 1 dot = 40μ, 1200dpi: 1 dot = 20μ</p> <table border="1" data-bbox="277 1032 756 1352"> <tr> <td>1</td> <td>[K] 1200</td> <td>*</td> <td>[0 to 20000 / 7510 / 1 dot] DFU</td> </tr> <tr> <td>2</td> <td>[FC,K] 1200</td> <td>*</td> <td>[0 to 20000 / 15038 / 1 dot] DFU</td> </tr> <tr> <td>3</td> <td>[FC,Y] 1200</td> <td>*</td> <td>[0 to 20000 / 10402 / 1 dot] DFU</td> </tr> <tr> <td>4</td> <td>[FC,M] 1200</td> <td>*</td> <td>[0 to 20000 / 1136 / 1 dot] DFU</td> </tr> <tr> <td>5</td> <td>[FC,C] 1200</td> <td>*</td> <td>[0 to 20000 / 5762 / 1 dot] DFU</td> </tr> <tr> <td>6</td> <td>[K] 600</td> <td>*</td> <td>[0 to 20000 / 3755 / 1 dot] DFU</td> </tr> <tr> <td>7</td> <td>[FC,K] 600</td> <td>*</td> <td>[0 to 20000 / 7519 / 1 dot] DFU</td> </tr> <tr> <td>8</td> <td>[FC,Y] 600</td> <td>*</td> <td>[0 to 20000 / 5201 / 1 dot] DFU</td> </tr> <tr> <td>9</td> <td>[FC,M] 600</td> <td>*</td> <td>[0 to 20000 / 568 / 1 dot] DFU</td> </tr> <tr> <td>10</td> <td>[FC,C] 600</td> <td>*</td> <td>[0 to 20000 / 2881 / 1 dot] DFU</td> </tr> </table>		1	[K] 1200	*	[0 to 20000 / 7510 / 1 dot] DFU	2	[FC,K] 1200	*	[0 to 20000 / 15038 / 1 dot] DFU	3	[FC,Y] 1200	*	[0 to 20000 / 10402 / 1 dot] DFU	4	[FC,M] 1200	*	[0 to 20000 / 1136 / 1 dot] DFU	5	[FC,C] 1200	*	[0 to 20000 / 5762 / 1 dot] DFU	6	[K] 600	*	[0 to 20000 / 3755 / 1 dot] DFU	7	[FC,K] 600	*	[0 to 20000 / 7519 / 1 dot] DFU	8	[FC,Y] 600	*	[0 to 20000 / 5201 / 1 dot] DFU	9	[FC,M] 600	*	[0 to 20000 / 568 / 1 dot] DFU	10	[FC,C] 600	*	[0 to 20000 / 2881 / 1 dot] DFU
1	[K] 1200	*	[0 to 20000 / 7510 / 1 dot] DFU																																								
2	[FC,K] 1200	*	[0 to 20000 / 15038 / 1 dot] DFU																																								
3	[FC,Y] 1200	*	[0 to 20000 / 10402 / 1 dot] DFU																																								
4	[FC,M] 1200	*	[0 to 20000 / 1136 / 1 dot] DFU																																								
5	[FC,C] 1200	*	[0 to 20000 / 5762 / 1 dot] DFU																																								
6	[K] 600	*	[0 to 20000 / 3755 / 1 dot] DFU																																								
7	[FC,K] 600	*	[0 to 20000 / 7519 / 1 dot] DFU																																								
8	[FC,Y] 600	*	[0 to 20000 / 5201 / 1 dot] DFU																																								
9	[FC,M] 600	*	[0 to 20000 / 568 / 1 dot] DFU																																								
10	[FC,C] 600	*	[0 to 20000 / 2881 / 1 dot] DFU																																								
919	[MScan Lgth Det] Main-scan Length Detection	1	MScan Lgth Det Enables or disables the main-scan length detection. [0 or 1 / 1 / -] Alphanumeric 0: Disable 1: Enable																																								
994	[MScan Reg Cor] Main-scan Registration Correction ([Color])	<p>Specifies the correction to the main-scan length. Main-scan length differs for each machine due to variations in parts used in the laser optics housing unit. Fine adjustment of main-scan length is done at the factory on each unit. This SP mode is DFU except for when replacing the laser optics housing unit. When replacing the unit, the data printed on the label attached to the new unit must be input with this SP mode.</p> <p>NOTE: When fine adjustment is required, the adjustment should be done with SP5-993-010 to 012. 1 dot = 20μ</p> <table border="1" data-bbox="277 1877 756 2002"> <tr> <td>1</td> <td>[Y]</td> <td></td> <td>[-128 to 127 / 0 / 1 dot/step] FA DFU</td> </tr> <tr> <td>2</td> <td>[M]</td> <td></td> <td>[-128 to 127 / 1 / 1 dot/step] FA DFU</td> </tr> <tr> <td>3</td> <td>[C]</td> <td></td> <td>[-128 to 127 / 1 / 1 dot/step] FA DFU</td> </tr> <tr> <td>4</td> <td>[K]</td> <td></td> <td>[-128 to 127 / 0 / 1 dot/step] FA DFU</td> </tr> </table>		1	[Y]		[-128 to 127 / 0 / 1 dot/step] FA DFU	2	[M]		[-128 to 127 / 1 / 1 dot/step] FA DFU	3	[C]		[-128 to 127 / 1 / 1 dot/step] FA DFU	4	[K]		[-128 to 127 / 0 / 1 dot/step] FA DFU																								
1	[Y]		[-128 to 127 / 0 / 1 dot/step] FA DFU																																								
2	[M]		[-128 to 127 / 1 / 1 dot/step] FA DFU																																								
3	[C]		[-128 to 127 / 1 / 1 dot/step] FA DFU																																								
4	[K]		[-128 to 127 / 0 / 1 dot/step] FA DFU																																								

2	Mode No. (Class 1, 2, and 3)		Function / [Setting]
995	[Motor Reset] Mirror Positioning Motor Reset		
	1	Motor Reset	Rotates the mirror position motors (CMY) by 250 pulses clockwise; then by 125 pulses counterclockwise. This moves the mirrors back to the initial position. Then, the settings of SP2-908-002 to 004 are reset to 0. When the line position adjustment fails, it is one of possible causes when the mirror position motor locks. Performing this SP mode can move the mirrors back to the original position if it locks. Then, do the forced line position adjustment (SP5-993-002).

SP3-XXX (Process)

3	Mode No. (Class 1, 2, and 3)		Function / [Setting]
005	[TD Initial] TD Sensor Initialization ([Color])		
	1	[K]	Initializes the developer. DFU
	2	[Y]	Press the Enter key to execute the initialization after the machine asks "Execute?".
	3	[M]	
	4	[C]	
	5	[All Color]	
6	Result	Displays the developer initialization result. [1 or 2 / - / -] 1: Success 2: Failure All colors are displayed. Values is displayed in the order K Y C M. e.g., 1 1 2 1: Initialization of Cyan failed but the others succeeded See the troubleshooting section for details.	
006	[Vcnt Initial] Vcnt Initial Setting Display ([Color])		
	1	[K]	Displays the initial Vcnt value.
	2	[Y]	[0 to 240 / <u>100</u> / 0.1/step]
	3	[M]	
007	[Vcnt Current] Vcnt Current Value Display ([Color])		
	1	[K]	Displays the current Vcnt value.
	2	[Y]	[0 to 240 / - / 0.1/step]
	3	[M]	
008	[Humidity]		
	1	Humidity	Displays the humidity measured by the humidity/temperature sensor. [0 to 100 / - / 1/step]
107	[Vsg Display] Vsg Display (Front or Rear)		
	1	Vsg F	* Displays the Vsg value of the front ID sensor. [0.00 to 5.00 / - / 0.01V/step] Vsg is normally 4.0 ± 0.5 V. If Vsg is out of the adjustment range and this is detected 3 times consecutively, it leads to SC385.
	2	LED Current F	* Displays the ID sensor LED current adjusted during Vsg adjustment. [0 to 1023 / - / 1]
	3	Vsg R	* Displays the Vsg value of the rear ID sensor. [0.00 to 5.00 / - / 0.01V/step] Vsg is normally 4.0 ± 0.5 V. If Vsg is out of the adjustment range and this is detected 3 times consecutively, it leads to SC385.
4	LED Current R	* Displays the ID sensor LED current adjusted during Vsg adjustment. [0 to 1023 / - / 1]	

Service Tables

3	Mode No. (Class 1, 2, and 3)		Function / [Setting]
120	[Dev. g Target] Development Gamma Target ([Color])		
	Adjusts the development gamma by changing the Vref value used for toner density control. Vref is automatically corrected so that the gamma measured during the process control self-check becomes "the value set with this SP mode ± 0.25"		
	1	[K]	* [100 to 300 / <u>155</u> / 1 mg/cm ² /KV / step] DFU
	2	[Y]	* [100 to 300 / <u>125</u> / 1 mg/cm ² /KV / step] DFU
	3	[M]	*
4	[C]	*	
121	[Dev. g Display] Development Gamma Display ([Color])		
	Displays the development gamma measured during the process control self-check.		
	1	[K]	[0 to 10000 / - / 1 mg/cm ² /KV /step]
	2	[Y]	Normal Range: 1.00 to 2.00
	3	[M]	
4	[C]		
122	[Vk Display] Vk Display ([Color])		
	1	[K]	Displays the current Vk value.
	2	[Y]	[-255 to 255 / - / 1/step]
	3	[M]	Normal Range: -50 to 50
	4	[C]	
123	[Vref Display] Current Vref Display ([Color])		
	1	[K]	Displays the current Vref value.
	2	[Y]	[0.0 to 5.0 / - / 0.1V/step]
	3	[M]	
	4	[C]	
125	[Process Contr.] Process Control		
	1	ON/OFF	* Enables or disables process control. [0 or 1 / <u>1</u> / 1/step] Alphanumeric 0: OFF (Use the fixed values for VD, VL and VB set with SP2-001, SP2-103, and SP2-201.) 1: ON
	2	LD Control	* Selects the LD control mode. [0 to 2 / <u>1</u> / 1/step] Alphanumeric 0: Fixed (at the value in SP2-103) 1: Controlled by process control 2: Controlled by LD power selection
	3	Auto TD Adj.	* Specifies when to perform the Auto Toner Density Adjustment. When performing the Auto Toner Density Adjustment, the machine supplies or consumes toner so that the development gamma is within ± 0.25 of the gamma target. [0 to 3 / <u>0</u> / 1/step] Alphanumeric 0: Disable 1: Initial process control self-check 2: Job end process control self-check 3: Initial & Job end process control self-check <i>Do not adjust unless advised by senior technical staff.</i>
126	[Forced SelfChk] Forced Self-check		
	1	Forced SelfChk	Performs a forced process control self-check.
	2	Forced TD Adj.	Performs a forced auto toner density adjustment. <i>Do not use unless advised by senior technical staff.</i>

3	Mode No. (Class 1, 2, and 3)			Function / [Setting]
902	[Pntr. Display] Pointer Table Display ([Color])			Displays the number in the pointer table that was selected during the latest process control self-check. [1 to 30 / - / 1/step]
1	[K]	*		
2	[Y]	*		
3	[M]	*		
4	[C]	*		
903	[M/A Target] M/A Target ([Color])			Adjusts the M/A (Mass per Area, mg/cm ²) value used during the process control self-check. Adjusting this changes the development bias. This causes the solid ID to increase or decrease. If developer capability causes an ID problem, toner density needs to be adjusted with SP3-120-1 to 4, depending on the color.
1	[K]	*		
2	[Y]	*		
3	[M]	*		
4	[C]	*		
903	[M/A Target] M/A Target ([Color])			Adjusts the M/A value used during the LD correction mode. This value is effective when SP3-125-2 "LD Control Selection" is set to "2". Adjusting this data effects the image reproduction especially in highlight areas.
1	[K]	*		
2	[Y]	*		
3	[M]	*		
4	[C]	*		
904	[M/A for LD] M/A Target for LD Correction ([Color])			Adjusts the M/A value used during the LD correction mode. This value is effective when SP3-125-2 "LD Control Selection" is set to "2". Adjusting this data effects the image reproduction especially in highlight areas.
1	[K]	*		
2	[Y]	*		
3	[M]	*		
4	[C]	*		
906	[PC SelfChk] Process Control Self-checks			Specifies the execution timing of the job end process control self-check. [0 to 999 / <u>200</u> / 1 print/step] The job end process control self-check is automatically done after a job is completed when 200 prints have been made since the last self-check. The counter for the job end process control self-check resets when one of the following process control self-checks is done. <ul style="list-style-type: none"> • Initial • Interval: Interrupt • Non-use Time • During Toner End When K prints are made, the number of prints is calculated with the K coefficient in SP3-906-5.
1	Job End	*		
2	Interrupt	*		

Service Tables

3		Mode No. (Class 1, 2, and 3)		Function / [Setting]
906	3	Non-use Time 1	*	Specifies the executing timing of the non-use time process control self-check. [0 to 999 / <u>0</u> / 1 print/step] 0: Disable The non-use time process control self-check is automatically done after the number of prints set with this SP mode have been made and no prints have been made for the time set with SP mode 3-906-4 since the last print job. If the conditions are met, the self-check will be done after the print job is completed. The counter is reset when the one of the following process control self-checks is done. <ul style="list-style-type: none"> • Initial • Interval: Job End • Interval: Interrupt
	4	Non-use Time 2	*	Specifies the executing timing of the non-use time process control self-check. [0 to 255 / <u>30</u> / 1 minutes/step] 0: Disable
	5	K Coefficient	*	Sets the coefficient to calculate the counter value for black-and-white prints. [0 to 100 / <u>100</u> / 1/step] DFU With the default setting (100), counters used for process control count up by 1 when 1 black-and-white print has been made.
910	[Vmin Display] Vmin Display ([Color])			
	1	[K]	*	Displays the current Vmin value for K
	2	[Color]	*	Displays the lowest current Vmin value for the colors (CMY).
911	[Vt Display Cur] Vt Current Display ([Color])			
	1	[K]	*	Displays the current Vt value.
	2	[Y]	*	[0.0 to 5.0 / - / 0.1V/step]
	3	[M]	*	
	4	[C]	*	
912	[Vt Display Ave] Vt Average Display ([Color])			
	1	[K]	*	Displays the average Vt value.
	2	[Y]	*	[0.0 to 5.0 / - / 0.1V/step]
	3	[M]	*	
	4	[C]	*	
913	[T. Supply Time] Toner Supply Time Display ([Color])			
	1	[K]	*	Displays the total toner supply clutch on time.
	2	[Y]	*	[0 to 5000 / - / 10 ms/step]
	3	[M]	*	
	4	[C]	*	



3	Mode No. (Class 1, 2, and 3)		Function / [Setting]
920	[OPC Refresh]		
	1	Temperature	* This SP determines the temperature threshold for determining whether refresh mode is done just after the machine is switched on. The charge roller generates NOx (nitrogen oxides), and these contaminate the OPC drum surface and may cause a smeared image. Just after the main switch is turned on, if the temperature measured by both the thermistor located at the right side on the laser optics housing unit and the temperature/humidity sensor is greater than the temperature specified in this SP mode, refresh mode is done before initial process control. During refresh mode, toner is developed on the OPC with 50V development potential and cleaned to remove NOx. This cycle is repeated a few times. [10 to 30 / 25 / 1°C /step]
	2	Humidity	* This SP determines the humidity threshold for determining whether refresh mode is done just after the machine is switched on. Just after the main switch is turned on, if the humidity measured by the temperature/humidity sensor is greater than the humidity specified in this SP mode, refresh mode is done before the initial process control self-check. [10 to 90 / 75 / 1%/step]
	3	Prints	* Specifies how often refresh mode is done. When the total number of prints since the last refresh mode exceeds the number specified in this SP mode, refresh mode is done before the job end process control self-check. [100 to 25500 / 200 / 100 prints/step]
	4	Mode Set	* Enables/disables refresh mode. [0 to 2 / 2 / 1/step] Alphanumeric 0: Disabled 1: Done at power on and toner end recovery 2: Done at power on, toner end recovery, and after the specified number of prints. NOTE: Refresh mode is done during the toner end recovery self-check after a new toner cartridge is installed.
5	Forced	Executes a forced refresh mode. Use this mode when the image is smeared. It takes about 1 minute. Also use after replacing the components of the transfer unit (see section 3).	

Service Tables

3	Mode No. (Class 1, 2, and 3)	Function / [Setting]						
921	<p>[Toner Refresh]</p> <p>Perform forced toner refresh mode. If dirty background appears on the front side of outputs with low image coverage, this may be caused by old toner remaining in the development unit attached to the carrier. Because of this, new toner supplied into the development unit does not get attracted to the carrier and will flow out and cause dirty background. When the above dirty background appears, check whether or not the development gamma is within the target (SP3-120 and 121). If the development gamma is within the target, do this SP mode. The machine automatically does the toner refresh mode in the following sequence.</p> <ol style="list-style-type: none"> 1. Consumes toner in the development unit without toner supply until toner end is detected 2. Starts toner recovery mode. 3. Starts process control self-check. 	<table border="1" style="width: 100%; border-collapse: collapse;"> <tr> <td style="width: 5%; text-align: center;">1</td> <td style="width: 40%;">[K]</td> <td style="width: 55%;"></td> </tr> <tr> <td style="text-align: center;">2</td> <td>All Color</td> <td></td> </tr> </table>	1	[K]		2	All Color	
1	[K]							
2	All Color							
975	<p>[P Ctrl Result] Process Control Self-check Result</p> <table border="1" style="width: 100%; border-collapse: collapse;"> <tr> <td style="width: 5%; text-align: center;">1</td> <td style="width: 40%;">P Ctrl Result</td> <td style="width: 55%;"></td> </tr> </table>	1	P Ctrl Result		<p>Displays the result of the latest process control self-check. [0 to 9999 / - / 1/step]</p> <p>All colors are displayed. The results are displayed in the order "K Y C M" e.g., 1 1 9 1: The self-check for Cyan failed but the others were successful</p> <p>See the troubleshooting section for details.</p>			
1	P Ctrl Result							

SP5-XXX (Mode)

5	Mode No. (Class 1, 2, and 3)		Function / [Setting]																																								
009	[Language]																																										
	1	Language	<p>* # P</p> <p>Selects the language for the control panel. [0 to 16 / 2 / 1/step]</p> <table border="1" data-bbox="770 432 1362 728"> <thead> <tr> <th>Data</th> <th>Language</th> <th>Data</th> <th>language</th> </tr> </thead> <tbody> <tr><td>0</td><td>No language</td><td>9</td><td>Norwegian</td></tr> <tr><td>1</td><td>Japanese</td><td>10</td><td>Danish</td></tr> <tr><td>2</td><td>English</td><td>11</td><td>Swedish</td></tr> <tr><td>3</td><td>American</td><td>12</td><td>Polish</td></tr> <tr><td>4</td><td>French</td><td>13</td><td>Portuguese</td></tr> <tr><td>5</td><td>German</td><td>14</td><td>Hungarian</td></tr> <tr><td>6</td><td>Italian</td><td>15</td><td>Czech</td></tr> <tr><td>7</td><td>Spanish</td><td>16</td><td>Finnish</td></tr> <tr><td>8</td><td>Dutch</td><td></td><td></td></tr> </tbody> </table> <p>NOTE: When changing language, the main switch has to be turned off and on to initialize the system.</p>	Data	Language	Data	language	0	No language	9	Norwegian	1	Japanese	10	Danish	2	English	11	Swedish	3	American	12	Polish	4	French	13	Portuguese	5	German	14	Hungarian	6	Italian	15	Czech	7	Spanish	16	Finnish	8	Dutch		
Data	Language	Data	language																																								
0	No language	9	Norwegian																																								
1	Japanese	10	Danish																																								
2	English	11	Swedish																																								
3	American	12	Polish																																								
4	French	13	Portuguese																																								
5	German	14	Hungarian																																								
6	Italian	15	Czech																																								
7	Spanish	16	Finnish																																								
8	Dutch																																										
045	[Counter Method]																																										
	1	Counter Method	<p>* P</p> <p>Selects the counting method if the meter charge mode is enabled with SP5-930-001. [0 or 1 / 0 / -] 0: Developments 1: Prints</p> <p>NOTE: The counting method can be changed only once, regardless of whether the counter value is negative or positive.</p>																																								
101	[Energy Saver]																																										
	3	Energy Saver 1	<p>* P</p> <p>After the end of a job, the machine enters Energy Saver mode (level 1) when this timer runs out. [0 to 60 / 0 / 10 sec/step]</p>																																								
	4	Energy Saver 2 (Auto OFF mode)	<p>* P</p> <p>After the end of a job, the machine enters Energy Saver mode (level 2) when this timer runs out. [0 to 3600 / 3600 / 60 sec/step]</p>																																								
104	[Double Count]																																										
	1	Double Count	<p>* P</p> <p>Specifies whether the counter is double clicked for A3/DLT size prints. [0 or 1 / 0 / -] 0: Normal count 1: Double count</p>																																								
305	[ES Level 2 Set]																																										
	1	ES Level 2 Set	<p>* P</p> <p>Enables or disables Energy Saver Level 2 (Auto Off mode). [0 or 1 / 0 / -] 0: Enabled 1: Disabled</p>																																								

Service Tables

5	Mode No. (Class 1, 2, and 3)		Function / [Setting]
801	[Memory Clear]		
	1	All	P Resets all the controller and engine settings to their defaults and the counters to 0. To clear the memory, enter this SP mode, press the Enter key, then turn the main switch off and on. NOTE: All settings are reset to the defaults. SMC sheets should be printed out before doing a memory clear. See NOTE 1 at the end of the SP table for a list of settings cleared.
	2	ENG All	Clears all the engine settings.
	3	SCS	Clears the system settings.
	4	IMH	Not used.
	5	MCS	P
	8	PRT	Clears the user mode system settings.
	11	NCS	Clears the network settings.
	15	ENG Setting	Clears the engine settings except for counters.
	16	ENG Counter	Clears all counters.
803	[Input Check]		
804	[Output Check]		
808	[Destination] Destination Code Display		
	1	Destination	* Displays the destination code.
809	[SC ON/OFF] SC Detection ON/OFF		
	1	SC ON/OFF	* Enable or disables the service call detection (SC codes will be ignored if disabling this SP mode). [0 or 1 / 0 / -] Alphanumeric 0: Enable 1: Disable
810	[SC Reset]		
	1	SC Reset	* Resets a type A service call condition. NOTE: Turn the main switch off and on after resetting the SC code.
811	[SN Display] Serial Number Display		
	2	SN Display	* Displays the machine serial number.
812	[FAX TEL No.]		
	2	FAX TEL No.	* P Sets the fax or telephone number for a service representative. This number is printed on the Counter List, which can be printed with the user's "Counter" menu if the Meter Charge mode is selected with SP5-930-1. This can be up to 13 characters (both numbers and alphabetic characters can be input).
832	[HDD Init.] HDD Initialization		
	1	HDD Init.	P Initializes the hard disk. Use this SP mode only in there is a hard disk error.

5	Mode No. (Class 1, 2, and 3)		Function / [Setting]																																					
833	[JobLog ON/OFF]																																							
7	JobLog ON/OFF	* P	Saves the result of the jobs in the job log. If this mode is enabled, the result is written on the HDD. If no HDD is installed, this feature is disabled even if this SP is set to 'enabled'. [0 or 1 / 0 / -] 0: Disabled 1: Enabled																																					
907	[Plug/Play] Plug & Play Name Selection																																							
1	Plug/Play	* P	Specifies the manufacturer and model name. [0 to 7 / 0 / 1/step] FA																																					
<table border="1"> <thead> <tr> <th></th> <th>MF</th> <th>Model Name</th> <th>NetBeui</th> </tr> </thead> <tbody> <tr> <td>0</td> <td>Ricoh</td> <td>Aficio AP3800C</td> <td>AficioAP3800</td> </tr> <tr> <td>1</td> <td>Ricoh</td> <td>ColorLaser AP828</td> <td>ColorAP828</td> </tr> <tr> <td>2</td> <td>Savin</td> <td>SLP38c</td> <td>SLP38c</td> </tr> <tr> <td>3</td> <td>Gestetner</td> <td>DSc38</td> <td>DSc38</td> </tr> <tr> <td>4</td> <td>NRG</td> <td>DSc38</td> <td>DSc38</td> </tr> <tr> <td>5</td> <td>Infotec</td> <td>IC 280</td> <td>IC280</td> </tr> <tr> <td>6</td> <td>Lanier</td> <td>2138 AG</td> <td>2138AG</td> </tr> <tr> <td>7</td> <td>Lanier</td> <td>2138 AH</td> <td>2138AH</td> </tr> </tbody> </table>						MF	Model Name	NetBeui	0	Ricoh	Aficio AP3800C	AficioAP3800	1	Ricoh	ColorLaser AP828	ColorAP828	2	Savin	SLP38c	SLP38c	3	Gestetner	DSc38	DSc38	4	NRG	DSc38	DSc38	5	Infotec	IC 280	IC280	6	Lanier	2138 AG	2138AG	7	Lanier	2138 AH	2138AH
	MF	Model Name	NetBeui																																					
0	Ricoh	Aficio AP3800C	AficioAP3800																																					
1	Ricoh	ColorLaser AP828	ColorAP828																																					
2	Savin	SLP38c	SLP38c																																					
3	Gestetner	DSc38	DSc38																																					
4	NRG	DSc38	DSc38																																					
5	Infotec	IC 280	IC280																																					
6	Lanier	2138 AG	2138AG																																					
7	Lanier	2138 AH	2138AH																																					
930	[Meter Charge] Meter Charge Mode																																							
1	ON/OFF	#	Enables or disables the Meter Charge mode. When enabling the Meter Charge mode, the "Counter" menu is added to the user menu. [0 or 1 / 0 / -] Alphanumeric 0: OFF 1: ON																																					

Service Tables

5		Mode No. (Class 1, 2, and 3)		Function / [Setting]																																																																					
930	3	Menu	#	<p>Selects the method for displaying the alert when the life of the parts in a maintenance kit has almost ended. [0 or 1 / <u>1</u> / -] Alphanumeric 0: Click 2 1: Click 1</p> <p>The following table shows the machine condition when the near end or end condition of each maintenance unit is detected. In this table, '-' means 'normal operation'</p> <table border="1"> <thead> <tr> <th rowspan="2"></th> <th colspan="3">Setting: 1 (Click 1)</th> <th colspan="3">Setting: 0 (Click 2)</th> </tr> <tr> <th>Near</th> <th>End</th> <th>Printing</th> <th>Near</th> <th>End</th> <th>Printing</th> </tr> </thead> <tbody> <tr> <td>A</td> <td>-</td> <td>Alert</td> <td>-</td> <td>-</td> <td>-</td> <td>-</td> </tr> <tr> <td>B</td> <td>-</td> <td>Alert</td> <td>-</td> <td>-</td> <td>-</td> <td>-</td> </tr> <tr> <td>C</td> <td>Alert</td> <td>Alert</td> <td>Stop</td> <td>Alert</td> <td>Alert</td> <td>Stop</td> </tr> <tr> <td>D</td> <td>-</td> <td>Alert</td> <td>-</td> <td>-</td> <td>-</td> <td>-</td> </tr> <tr> <td>E</td> <td>Alert</td> <td>Alert</td> <td>Stop</td> <td>Alert</td> <td>Alert</td> <td>Stop</td> </tr> <tr> <td>F</td> <td>-</td> <td>Alert</td> <td>-</td> <td>-</td> <td>-</td> <td>-</td> </tr> <tr> <td>G</td> <td>Alert</td> <td>Alert</td> <td>Stop</td> <td>Alert</td> <td>Alert</td> <td>Stop</td> </tr> <tr> <td>H</td> <td>-</td> <td>Note</td> <td>-</td> <td>-</td> <td>-</td> <td>-</td> </tr> </tbody> </table> <p>A: Color PCU B: Color Development Unit C: Fusing Unit D: Black Development Unit E: Waste Toner Bottle F: Black PCU G: Oil Supply Unit H: Paper Feed Rollers</p> <p>NOTE: SP5-930-004 allows the alert for the paper feed roller to be displayed.</p>		Setting: 1 (Click 1)			Setting: 0 (Click 2)			Near	End	Printing	Near	End	Printing	A	-	Alert	-	-	-	-	B	-	Alert	-	-	-	-	C	Alert	Alert	Stop	Alert	Alert	Stop	D	-	Alert	-	-	-	-	E	Alert	Alert	Stop	Alert	Alert	Stop	F	-	Alert	-	-	-	-	G	Alert	Alert	Stop	Alert	Alert	Stop	H	-	Note	-	-	-	-
	Setting: 1 (Click 1)			Setting: 0 (Click 2)																																																																					
	Near	End	Printing	Near	End	Printing																																																																			
A	-	Alert	-	-	-	-																																																																			
B	-	Alert	-	-	-	-																																																																			
C	Alert	Alert	Stop	Alert	Alert	Stop																																																																			
D	-	Alert	-	-	-	-																																																																			
E	Alert	Alert	Stop	Alert	Alert	Stop																																																																			
F	-	Alert	-	-	-	-																																																																			
G	Alert	Alert	Stop	Alert	Alert	Stop																																																																			
H	-	Note	-	-	-	-																																																																			
	4	Paper Feed	#	<p>Determines whether to display the alert when the life of the paper feed rollers is nearly ended. [0 or 1 / <u>0</u> / -] Alphanumeric 0: No Alert 1: Alert</p>																																																																					
	5	Paper Trans.	#	<p>Determines whether to display the alert when the life of the transfer unit is nearly ended. [0 or 1 / <u>0</u> / -] Alphanumeric 0: No Alert 1: Alert</p>																																																																					
	6	Factory Use		DFU																																																																					

5	Mode No. (Class 1, 2, and 3)		Function / [Setting]
961	[Finisher Stack] Finisher Maximum Stack		
	1	Finisher Stack	* # P Enables or disables maximum stack mode for the lower shift tray only in staple mode. If this is enabled, the upper tray can be used for stacking 500 sheets but it stays at the upper exit (will not be used for stapling mode), and the lower tray is used for stacking up to 2,000 sheets. If this is disabled, the upper tray can be used for stacking 500 sheets and the lower tray for 1,500 sheets. [0 or 1 / 1 / -] 0: Disabled 1: Enabled NOTE: The main switch must be turned off and on to effect the setting change.
989	[Loop Back Test]		
	1	Duplex	Executes a communication test with peripherals by using a special tool (connector) which is unique for each peripheral. The machine checks if the communication with the peripherals is OK or NG; then displays the result. DFU
	3	Finisher	
	4	PFU	
990	[SMC Print]		
	2	All	Prints out the SMC sheets.
	4	Logging	
	6	Non-Default	
	7	NIB Summary	
991	[Jam OFF/ON]		
	Jam ON/OFF		
	1	Jam ON/OFF	Enables or disables jam detection. [0 or 1 / 0 / -] Alphanumeric 0: Enable 1: Disable
993	[Line Adj.]		
	Line Positioning Adjustment ([Color]) M: Main-scan, S: Sub-scan, Reg.: Registration, Mag.: Magnification For example: M Reg = Main scan registration		
	1	Mode Selection	* Specifies when the automatic line position adjustment is done. [0 to 2 / 1 / 1/step] Alphanumeric 0: Never done 1: Done at a) all process control self checks except after toner end recovery and developer initialization, b) new PCU detected, and c) the temperature has changed by 5°C since the last adjustment 2: As for setting '1', except it is not done during self-checks. However, it is done at the initial process control self check. The size of the 5°C difference can be changed with SP5-993-3
	2	Execute	* Use to make a line position adjustment.

Service Tables

5	Mode No. (Class 1, 2, and 3)			Function / [Setting]
993	3	Temperature	*	Specifies the temperature for starting the line positioning adjustment. [3 to 15 / <u>5</u> / 1°C] The line position adjustment automatically starts when the temperature differs by the amount specified in this SP mode from the temperature when the last adjustment was done. There are two thermistors on the laser optics-housing unit. The thermistor close to the fusing unit monitors the temperature for this adjustment.
	4	Intrpt ON/OFF	*	Enables or disables the line position adjustment during a print job when the temperature differs by the amount specified in SP5-993-003 from the temperature at the last adjustment. [0 or 1 / <u>1</u> / -] Alphanumeric 0: Disabled 1: Enabled
	5	Stand-by	*	Enables or disables the line position adjustment during stand-by mode when the temperature differs by the amount specified in SP5-993-003 from the temperature at the last adjustment. [0 or 1 / <u>0</u> / -] Alphanumeric 0: Disabled 1: Enabled
	6	Job Start		Enables or disables the line position adjustment just before starting a color print job when the temperature differs by the amount specified in SP5-993-003 from the temperature when the machine woke up from energy saver mode. [0 or 1 / <u>1</u> / -] 0: Disabled 1: Enabled
	7	Result	*	Displays the result of the latest line position adjustment in 4 digits. First 2 digits: Error detected on the front ID sensor Last 2 digits: Error detected on the rear ID sensor Refer to the Troubleshooting section for more details about the two-digit codes.
	8	Exe. Counter	*	Displays how many times the line position adjustment has been executed. Counts up by +1 normally. After a forced adjustment and a PCU replacement, it counts up +3 Also includes adjustments done at the factory.
	9	Error Counter	*	Displays how many times errors have been detected during the line position adjustment.
<p>The way that the auto line position adjustment is done can be adjusted using the following SP modes (SP5-993-010 to 021). These are coefficients used for the adjustment. Normally, do not change except if the automatic adjustment gives poor results immediately after installing a new optics housing unit. Change the value then do a forced line position adjustment (SP 5-993-2) to check the effects of the changes. Example: If magenta is always shifted one dot to the left, reduce 5-993-11 by 1.</p>				
	10	M Reg. [Y]	*	A fine adjustment to the main-scan registration.
	11	M Reg. [M]	*	[-128 to 127 / <u>0</u> / 1 dot/step] FA DFU
	12	M Reg. [C]	*	1 dot = 20μ

5	Mode No. (Class 1, 2, and 3)			Function / [Setting]
993	13	M Mag. [Y]	*	A fine adjustment to the main-scan magnification. [-100 to 100 / 0 / 0.01 %/step] FA, DFU
	14	M Mag. [M]	*	
	15	M Mag. [C]	*	
	16	S Reg. 600[Y]	*	A fine adjustment to the sub-scan registration for each color (color registration). [-128 to 127 / 0 / 1 dot/step] DFU 600dpi: 1 dot = 40μ 1200 dpi: 1 dot = 20μ
	17	S Reg. 600M[*	
	18	S Reg. 600[C]	*	
	19	S Reg. 1200[Y]	*	
	20	S Reg. 1200[M]	*	
	21	S Reg. 1200[C]	*	
	22	Interrupt 1		
23	Interrupt 2		*	Performs the line position adjustment when the number of prints reaches the number specified in this SP mode regardless of the temperature change. [0 to 350 / 0 / 50 prints/step] DFU 0: Disable
24	Mscan Lgth Det		*	Performs the main scan length detection when the polygon motor has operated consecutively for the time specified in this SP mode. [100 to 950 / 200 / 50 s/step]
994	[Unit Set] Maintenance Unit Detection ON/OFF			
1	Dev/PCU		* #	Enables or disables PCU and development unit detection. [0 or 1 / 0 / -] Alphanumeric 0: Enable 1: Disable NOTE: If this mode is disabled, new unit detection also does not function. Use this mode as a temporary measure, only when the micro-switches are defective.
2	Oil Unit		* #	This is for the oil supply unit only, and not the fusing unit [0 or 1 / 0 / -] Alphanumeric 0: Enable 1: Disable NOTE: Use this mode as a temporary measure, only when the unit detection mechanism is defective.

Service Tables

5	Mode No. (Class 1, 2, and 3)		Function / [Setting]
997	[Test Pattern]		
	1	Tray Selection	Selects the tray for making a test print. [0 to 4 / <u>1</u> / 1/step] 0: By-pass Table 1: Tray 1 2: Tray 2 3: Tray 3 4: Tray 4 NOTE: The machine makes a test pattern on the paper size loaded in the selected paper tray.
	2	Pattern	Selects a test pattern. [0 to 23 / <u>0</u> / 1/step] 0: None 1: 1-dot sub-scan line 2: 2-dot sub-scan line 3: 1-dot main-scan line 4: 2-dot main-scan line 5: 1-dot grid pattern (fine) 6: 2-dot grid pattern (fine) 7: 1-dot grid pattern (rough) 8: 2-dot grid pattern (rough) 9: 1-dot slant grid pattern 10: 2-dot slant grid pattern 11: 1-dot pattern 12: 2-dot pattern 13: 4-dot pattern 14: 1-dot trimming pattern 15: 2-dot trimming pattern 16: Cross stitch: sub-scan 17: Cross stitch: main-scan 18: Belt pattern 19: Belt pattern (vertical) 20: Checkered Flag 21: Grey scale (vertical) 22: Grey scale (Horizontal) 23: Solid
	3	Single Color	Selects the color for making a test pattern. [0 to 6 / <u>6</u> / 1/step] Alphanumeric 0: Red 1: Green 2: Blue 3: Yellow 4: Magenta 5: Cyan 6: Black
	4	Color Mode	Selects the color mode for making a test print. [0 or 1 / <u>0</u> / 1/step] Alphanumeric 0: Full Color 1: Single Color
	5	Resolution	Selects the resolution for making a test print. [0 to 2 / <u>1</u> / 1/step] Alphanumeric 0: 600x600 1: 1200x600 2: 1200x1200
	6	By-pass P-size	Selects the paper size for making a test pattern from the by-pass table. [0 to 3 / <u>0</u> / 1/step] Alphanumeric 0: A4 LEF 1: LT LEF 2: A3 3: DLT

5	Mode No. (Class 1, 2, and 3)			Function / [Setting]
	997	7	Print	

SP6-XXX (Peripherals)

6	Mode No. (Class 1, 2, and 3)		Function / [Setting]	
110	[Punch] Punch Positioning			
	1	Punch 1	*	Adjusts the punching position.
	2	Punch 2	*	Punch 1 US: 2 punch holes Europe: 2 punch holes North Europe: 4 punch holes Punch 2 US: 3 punch holes Europe: 4 punch holes Increment: Holes move toward the paper center. Decrement: Holes move toward the paper edge. [-7.5 to 7.5 / 0 / 0.5 mm/step]
111	[Staple] Staple Position			
	1	Staple	*	Adjusts the stapling position. Increment: Staple position moves toward the edge of paper. Decrement: Staple position moves toward the center of paper. [-3.5 to 3.5 / 0 / 0.5 mm/step] NOTE: Although the adjustable range is ± 3.5 mm, the stapling position can be changed only by 1.0 mm when stapling one position at the front or rear side even when the input value is more than 1.0.

SP7-XXX (Data Log)

7	Mode No. (Class 1, 2, and 3)		Function / [Setting]
003	[M/C Counter] Meter Charge Counter (Print, Development)		
	1	P: Total	* P Displays the values of the color counters. [-9999 to 9999999 / <u>0</u> / 1/step] These SP modes are development counters for the meter charge mode. These SP modes are used for Japanese market only. These SP modes are print counters for the meter charge mode.
	7	P: B&W	
	8	P: Full Color	
	10	D: Color	
	11	D: B&W	
	20	P: Full Color	
	21	P: B&W/Single	
	22	P: Single	
	23	P: B&W	
	25	P: Full Color	
	28	P: Color	
	29	P: B&W	
	30	P: Color Total	
007	[Other Counter]		
	1	Duplex	* P Displays counter values. [0 to 9999999 / <u>0</u> / 1 sheet/step]
	2	A3/DLT/Over420	
	3	Staple	
101	[Size Counter] Paper Size Counter		
	4	A3	* P Displays the counter values for each paper size. [0 to 9999999 / <u>0</u> / 1 sheet/step]
	5	A4	
	6	A5	
	13	B4	
	14	B5	
	32	11 x 17	
	36	8 1/2 x 14	
	38	8 1/2 x 11	
	44	5 1/2 x 8 1/2	
	128	Others	
204	[Feed Counter] Paper Feed Section Counter		
	1	Tray 1	* P Displays the number of sheets fed from each paper feed station. [0 to 9999999 / <u>0</u> / 1 sheet/step] NOTE: The LCT is counted as the 3rd feed station.
	2	Tray 2	
	3	Tray 3/LCT	
	4	Tray 4	
	5	By-pass	
	6	Duplex	
209	[Punch Counter]		
	1	Punch	* P Displays the number of times hole punching has been done. [0 to 9999999 / <u>0</u> / 1/step]
401	[SC Counter]		
	1	SC Counter	* P Displays the number of SC codes detected. [0 to 9999 / <u>0</u> / 1/step]
502	[Total Jam]		
	1	Total Jam	* P Displays the total number of jams detected. [0 to 9999 / <u>0</u> / 1 sheet/step]

Service Tables

7	Mode No. (Class 1, 2, and 3)	Function / [Setting]																																																																																																																		
504	<p>[Jam Location] D: Duplex, MB: Mail Box, F; Finisher, E: External, I: Internal ON: On check, OFF: Off Check</p> <table border="1"> <tr><td>3</td><td>Tray 1:ON</td><td></td></tr> <tr><td>4</td><td>Tray 2:ON</td><td></td></tr> <tr><td>5</td><td>Tray 3/LCT:ON</td><td></td></tr> <tr><td>6</td><td>Tray 4:ON</td><td></td></tr> <tr><td>8</td><td>Regist.:ON</td><td></td></tr> <tr><td>9</td><td>E Tray:ON</td><td></td></tr> <tr><td>10</td><td>I Tray:ON</td><td></td></tr> <tr><td>11</td><td>D:ON</td><td></td></tr> <tr><td>12</td><td>D Exit 1:ON</td><td></td></tr> <tr><td>13</td><td>D Exit 2:ON</td><td></td></tr> <tr><td>14</td><td>D Exit 3:ON</td><td></td></tr> <tr><td>15</td><td>D: Feed: ON</td><td></td></tr> <tr><td>20</td><td>MB Upper:ON</td><td></td></tr> <tr><td>21</td><td>MB Lower:ON</td><td></td></tr> <tr><td>51</td><td>Tray 1:OFF</td><td></td></tr> <tr><td>52</td><td>Tray 2:OFF</td><td></td></tr> <tr><td>53</td><td>Tray 3:OFF</td><td></td></tr> <tr><td>54</td><td>Tray 4:OFF</td><td></td></tr> <tr><td>61</td><td>Regist: OFF</td><td></td></tr> <tr><td>63</td><td>E Tray:OFF</td><td></td></tr> <tr><td>64</td><td>I Tray:OFF</td><td></td></tr> <tr><td>65</td><td>D:OFF</td><td></td></tr> <tr><td>66</td><td>D Exit 1:OFF</td><td></td></tr> <tr><td>67</td><td>D Exit 2:OFF</td><td></td></tr> <tr><td>68</td><td>D Exit 3:OFF</td><td></td></tr> <tr><td>69</td><td>D Feed:OFF</td><td></td></tr> <tr><td>100</td><td>F Entrance</td><td></td></tr> <tr><td>101</td><td>F Shift Tray 1</td><td></td></tr> <tr><td>102</td><td>F Shift Tray 2</td><td></td></tr> <tr><td>103</td><td>F Staple</td><td></td></tr> <tr><td>104</td><td>F Exit</td><td></td></tr> <tr><td>105</td><td>F Drive</td><td></td></tr> <tr><td>106</td><td>F Tray Up/Down</td><td></td></tr> <tr><td>107</td><td>F Jogger</td><td></td></tr> <tr><td>108</td><td>F Staple</td><td></td></tr> <tr><td>109</td><td>F Exit</td><td></td></tr> <tr><td>110</td><td>F Punch</td><td></td></tr> <tr><td>111</td><td>F Jam Clear</td><td></td></tr> </table>	3	Tray 1:ON		4	Tray 2:ON		5	Tray 3/LCT:ON		6	Tray 4:ON		8	Regist.:ON		9	E Tray:ON		10	I Tray:ON		11	D:ON		12	D Exit 1:ON		13	D Exit 2:ON		14	D Exit 3:ON		15	D: Feed: ON		20	MB Upper:ON		21	MB Lower:ON		51	Tray 1:OFF		52	Tray 2:OFF		53	Tray 3:OFF		54	Tray 4:OFF		61	Regist: OFF		63	E Tray:OFF		64	I Tray:OFF		65	D:OFF		66	D Exit 1:OFF		67	D Exit 2:OFF		68	D Exit 3:OFF		69	D Feed:OFF		100	F Entrance		101	F Shift Tray 1		102	F Shift Tray 2		103	F Staple		104	F Exit		105	F Drive		106	F Tray Up/Down		107	F Jogger		108	F Staple		109	F Exit		110	F Punch		111	F Jam Clear		<p>Displays the number of jams according to the location where jams were detected. NOTE: The LCT is counted as the 3rd feed station.</p>
3	Tray 1:ON																																																																																																																			
4	Tray 2:ON																																																																																																																			
5	Tray 3/LCT:ON																																																																																																																			
6	Tray 4:ON																																																																																																																			
8	Regist.:ON																																																																																																																			
9	E Tray:ON																																																																																																																			
10	I Tray:ON																																																																																																																			
11	D:ON																																																																																																																			
12	D Exit 1:ON																																																																																																																			
13	D Exit 2:ON																																																																																																																			
14	D Exit 3:ON																																																																																																																			
15	D: Feed: ON																																																																																																																			
20	MB Upper:ON																																																																																																																			
21	MB Lower:ON																																																																																																																			
51	Tray 1:OFF																																																																																																																			
52	Tray 2:OFF																																																																																																																			
53	Tray 3:OFF																																																																																																																			
54	Tray 4:OFF																																																																																																																			
61	Regist: OFF																																																																																																																			
63	E Tray:OFF																																																																																																																			
64	I Tray:OFF																																																																																																																			
65	D:OFF																																																																																																																			
66	D Exit 1:OFF																																																																																																																			
67	D Exit 2:OFF																																																																																																																			
68	D Exit 3:OFF																																																																																																																			
69	D Feed:OFF																																																																																																																			
100	F Entrance																																																																																																																			
101	F Shift Tray 1																																																																																																																			
102	F Shift Tray 2																																																																																																																			
103	F Staple																																																																																																																			
104	F Exit																																																																																																																			
105	F Drive																																																																																																																			
106	F Tray Up/Down																																																																																																																			
107	F Jogger																																																																																																																			
108	F Staple																																																																																																																			
109	F Exit																																																																																																																			
110	F Punch																																																																																																																			
111	F Jam Clear																																																																																																																			
506	<p>[Jam Paper Size]</p> <table border="1"> <tr><td>4</td><td>A3</td><td></td></tr> <tr><td>5</td><td>A4</td><td></td></tr> <tr><td>13</td><td>B4</td><td></td></tr> <tr><td>14</td><td>B5</td><td></td></tr> <tr><td>32</td><td>11 x 17</td><td></td></tr> <tr><td>36</td><td>8 1/2 x 14</td><td></td></tr> <tr><td>38</td><td>8 1/2 x 11</td><td></td></tr> <tr><td>44</td><td>5 1/2 x 8 1/2</td><td></td></tr> <tr><td>128</td><td>Others</td><td></td></tr> </table>	4	A3		5	A4		13	B4		14	B5		32	11 x 17		36	8 1/2 x 14		38	8 1/2 x 11		44	5 1/2 x 8 1/2		128	Others		<p>* P Displays the number of jams according to the paper size. [0 to 9999 / 0 / 1 sheet/step]</p>																																																																																							
4	A3																																																																																																																			
5	A4																																																																																																																			
13	B4																																																																																																																			
14	B5																																																																																																																			
32	11 x 17																																																																																																																			
36	8 1/2 x 14																																																																																																																			
38	8 1/2 x 11																																																																																																																			
44	5 1/2 x 8 1/2																																																																																																																			
128	Others																																																																																																																			

7	Mode No. (Class 1, 2, and 3)		Function / [Setting]															
507	[Jam History]		Displays the 10 most recently detected paper jams.															
	1	Latest		* P														
	2	Latest-1																
	3	Latest-2																
	4	Latest-3																
	5	Latest-4																
	6	Latest-5																
	7	Latest-6																
	8	Latest-7																
	9	Latest-8																
	10	Latest-9																
803	[PM Counter]		(Sheets or Rotations, Unit, [Color]) Dev.: Development Unit, PF: Paper Feed Rollers, Oil Supply: Oil Supply Unit, Fusing: Fusing Unit, Transfer: Transfer Unit															
	Displays the number of sheets printed for each current maintenance unit. [0 to 9999999 / 0 / 1 sheet/step]																	
	1	S:PCU [K]		PM counters click up based on the number of A4 (LT) LEF size sheets printed. Therefore, the A3 (DLT) Double Count is activated. The Double Count cannot be deactivated.														
	2	S:PCU [Y]																
	3	S:PCU [M]																
	4	S:PCU [C]																
	5	S:Dev. [K]																
	6	S:Dev. [Y]																
	7	S:Dev. [M]																
	8	S:Dev. [C]																
	9	S:Oil Supply																
	10	PF By-pass																
	11	PF Tray 1																
	12	PF Tray 2																
	13	PF Tray 3/LCT																
	14	PF Tray 4																
	15	S:Fusing																
	16	S:Transfer																
	17	R:PCU [K]		Displays the number of revolutions of motors or clutches for each current maintenance unit. [0 to 9999999 / 0 / 1 revolution/step]														
	18	R:PCU [Y]																
	19	R:PCU [M]																
	20	R:PCU [C]																
	21	R:Dev. [K]																
	22	R:Dev. [Y]																
	23	R:Dev. [M]																
	24	R:Dev. [C]																
	25	R:Oil Supply																
	26	R:Fusing																
	27	R:Transfer																

Service Tables

7	Mode No. (Class 1, 2, and 3)		Function / [Setting]
804	[PM Clear] PM Counter Clear (Unit, [Color]) Dev.: Development Unit, PF: Paper Feed Rollers, Transfer: Transfer Unit		
	1	PCU [K]	Clears the PM counter.
	2	PCU [Y]	Press the Enter key after the machine asks
	3	PCU [M]	"Execute?".
	4	PCU [C]	When a unit is replaced, the machine
	5	Dev. [K]	automatically detects that the new unit is installed.
	6	Dev. [Y]	Then, the current PM counter value is
	7	Dev. [M]	automatically moved to the b PM Counter -
	8	Dev. [C]	Previous (SP7-906-1 to 20) and is reset to "0".
	9	Oil Supply	NOTE: The LCT is counted as the 3rd feed
	10	PF By-pass	station.
	11	PF Tray 1	
	12	PF Tray 2	
	13	PF Tray 3/LCT	
	14	PF Tray 4	
	15	Fusing	
	16	Transfer	
	50	All	
807	[SC/Jam Clear] SC/Jam Counter Clear		
	1	SC/Jam Clear	* P Clears the counters related to SC codes and paper jams.
808	[Counter Clear]		
	1	Counter Clear	* P Clears all counters. See NOTE 1 after the SP table for a list of settings cleared.
816	[Tray Clear] Paper Tray Counter Clear		
	1	Tray 1	* P Clears the counters (SP7-204) for the number of
	2	Tray 2	sheets fed from the paper feed stations.
	3	Tray 3/LCT	NOTE: The LCT is counted as the 3rd feed
	4	Tray 4	station.
	6	Duplex	
825	[Counter Reset]		
	1	Counter Reset	P Rests the total counter values to "0". NOTE: This SP mode can be done only once, while the counter values are less than 0.
832	[Diag. Result] Diagnostic Result		
	1	Diag. Result	* P Displays the result of the diagnostics.
901	[Asset Info]		
	1	File Name	P Records the location where a problem is detected
	2	# of Lines	in the program. The data stored in this SP is used
	3	Location	for problem analysis. DFU

7	Mode No. (Class 1, 2, and 3)		Function / [Setting]
905	[Alert Display]		
	7	Fusing: Alert	Specifies the timing for displaying the near-end condition. With the default setting, near-end is detected and the alert lights on the panel 2.5K prints before detecting the end condition. The unit life is 9303K revolutions. Increment: Delays the alert display timing. Decrement: Hastens the alert display timing. 1.0K prints = approximately 93K revolutions [0 to 20000 / <u>9070</u> / 1 K revolutions/step]
	9	Oil: Alert	Specifies the timing for displaying the near-end condition. With the default setting, near-end is detected and the alert lights on the panel 2.5K prints before detecting the end condition. The unit life is 1860 revolutions. Increment: Delays the alert display timing. Decrement: Hastens the alert display timing. 1.0K prints = 93 [0 to 10000 / <u>1628</u> / 1 K revolutions/step]
906	[PMCounter-PREV] PM Counter - Previous		
	(Sheets or Rotations, Unit, [Color]), Dev.: Development Unit		
	1	S:PCU [K]	Displays the number of sheets printed with the previous maintenance units.
	2	S:PCU [Y]	
	3	S:PCU [M]	
	4	S:PCU [C]	
	5	S:Dev. [K]	
	6	S:Dev. [Y]	
	7	S:Dev. [M]	
	8	S:Dev. [C]	
	9	S:Oil Supply	
	10	S:Fusing	
	11	R:PCU [K]	Displays the number of revolutions for motors or clutches in the previous maintenance units.
	12	R:PCU [Y]	
	13	R:PCU [M]	
	14	R:PCU [C]	
	15	R:Dev. [K]	
	16	R:Dev. [Y]	
	17	R:Dev. [M]	
	18	R:Dev. [C]	
19	R:Oil Supply		
20	R:Fusing		
907	[Check Sum]		
	1	Engine Main	Displays the check sum of the firmware.
2	Engine MUSIC		
910	[Firmware PN] Firmware Part Number		
	1	Controller	Displays the part number of the firmware.
2	Engine	* P	

Service Tables

7		Mode No. (Class 1, 2, and 3)		Function / [Setting]
910	5	ADF		Displays the part number of the firmware.
	7	Finisher		
	9	PFU		
	11	Mail Box		
	13	Duplex		
	14	MUSIC		
	18	NIB		
	200	Factory		
	204	Printer		
	209	Test		
	210	MIB		
911	[Firmware Ver.]			Displays the firmware version.
	1	Controller	*	
	2	Engine	P	
	5	ADF		
	7	Finisher		
	9	PFU		
	11	Mail Box		
	13	Duplex		
	14	MUSIC		
	18	NIB		
	200	Factory		
	204	Printer		
	209	Test		
	210	MIB		

NOTE 1: Memory Clear (SP5-801 & 7-808)

The following tables list the items that are cleared. The serial number information, meter charge setting (SP5-930), and meter charge counters (SP7-003) are not cleared.

5	Mode No. (Class 1, 2, and 3)		SP Modes or User Setting to be cleared	
801	[Memory Clear]			
	1	All	P	All items cleared by SP5-801-002, 003, 004, 005, 008, 011, 015, and 016.
	2	ENG All		All engine related SP modes except for the following: <ul style="list-style-type: none"> • Serial number information • SP5-930
	3	SCS	P	SP5-009, 101, 104, 305, 812, 833, 961, and 970 SP7-101, 204, 209, 401, 502, 504, 506, and 507
	4	IMH	P	No SP modes are cleared. But, all files stored in the HDD are cleared.
	5	MCS	P	No SP modes are cleared.
	8	PRT	P	The following service settings: <ul style="list-style-type: none"> • Bit switches • Gamma settings (User & Service) • Toner Limit The following user settings: <ul style="list-style-type: none"> • Tray Priority • Menu Protect • System Setting except for setting of Energy Saver • I/F Setup (I/O Buffer and I/O Timeout) • PCL Menu
	11	NCS	P	All setting of Network Setup (User Menu)
	15	ENG Setting		All engine related SP modes except for the following: <ul style="list-style-type: none"> • Serial number information • SP modes related to meter charge • Counters and logging data
	16	ENG Counter		All counters and logging data related to engine
7				
808	[Counter Clear]			
	1	Counter Clear	P	SP7-101, 204, 209, 502, 504, 506, and 507

Service Tables

5.3.2 INPUT CHECK TABLE

When entering the Input Check mode, 8 digits display the result for a section. Each digit corresponds to a different device as shown in the table.

Bit No.	7	6	5	4	3	2	1	0
Result	0 or 1	0 or 1	0 or 1	0 or 1	0 or 1	0 or 1	0 or 1	0 or 1

SP5-803 -XXX	Bit	Description	Reading	
			0	1
1	Paper Tray 1			
	0	Paper End Sensor	Paper end	Paper detected
	1	Paper Lift Sensor	Deactivated	Activated (Actuator not inside sensor)
	2	Paper Height Sensor 1	See Table 1.	
	3	Paper Height Sensor 2		
4	Tray Set	Not set	Set	
2	Paper Tray 2			
	0	Paper End Sensor	Paper end	Paper detected
	1	Paper Lift Sensor	Deactivated	Activated (Actuator not inside sensor)
	2	Paper Height Sensor 1	See Table 1. 1: Activated (Actuator inside sensor)	
	3	Paper Height Sensor 2		
	4	Paper Size Switch 1	See Table 2. 1: Pushed	
	5	Paper Size Switch 2		
	6	Paper Size Switch 3		
7	Paper Size Switch 4			
3	By-pass Table			
	0	Paper End Sensor	Paper end	Paper detected
	1	Paper Size 1	See Table 3.	
	2	Paper Size 2		
	3	Paper Size 3		
4	Paper Size 4			
4	Doors			
	0	Front Door Switch	Opened	Closed
	1	Left Door Switch	Opened	Closed
	2	Right Door Switch	Opened	Closed
	3	Vertical Transport Switch	Opened	Closed
	4	Duplex Inverter Unit Switch	Opened	Closed
5	Paper Feed			
	0	Relay Sensor	Paper not detected	Paper detected
	1	Vertical Transport Sensor	Paper not detected	Paper detected
	2	Upper Relay Sensor (PFU)	Paper not detected	Paper detected
	3	Lower Relay Sensor (PFU)	Paper not detected	Paper detected
	4	Registration Sensor	Paper not detected	Paper detected
	5	Duplex Inverter Sensor	Paper not detected	Paper detected
6	Duplex Feed Sensor	Paper not detected	Paper detected	

SP5-803 -XXX	Bit	Description	Reading	
			0	1
6	Paper Exit			
	0	Fusing Exit Sensor	Paper not detected	Paper detected
	1	Paper Exit Sensor	Paper not detected	Paper detected
	2	Duplex Exit Sensor 1	Paper not detected	Paper detected
	3	Duplex Exit Sensor 2	Paper not detected	Paper detected
	4	Duplex Exit Sensor 3	Paper not detected	Paper detected
	5	Exit Upper Limit Sensor	Not full	Full
7	Fusing Unit			
	0	Fusing Unit (Set)	Not set	Set
	1	Fusing Unit (New)	0 to 1 : New unit installed	
	2	Oil Supply Unit (Set)	Set	Not set
	3	Oil Supply Unit (New)	1 to 0 : New unit installed	
	4	European Version	US	Europe
8	Motor Lock			
	0	Development Drive Motor - CMY	Not locked	Locked
	1	Development Drive Motor - K	Not locked	Locked
	2	-	-	-
	3	-	-	-
	4	-	-	-
	5	Fusing Fan Motor	Locked (normal speed)	Low speed or not working
	6	-	-	-
	7	-	-	-
9	Dev. Unit/ PCU			
	0	Development Unit - K	Not set	Set
	1	Development Unit - C	Not set	Set
	2	Development Unit - M	Not set	Set
	3	Development Unit - Y	Not set	Set
	4	PCU - K	Not set	Set
	5	PCU - C	Not set	Set
	6	PCU - M	Not set	Set
	7	PCU - Y	Not set	Set
13	Others			
	0	LD H.P. Sensor	Not H.P.	H.P.
	1	Transfer Belt Set Sensor	Not contact	Contact
	2	Transfer Belt H.P. Sensor	Not. H.P.	H.P.
	3	Used Toner Sensor	Not full	Full
	4	Used Toner Bottle Set Sensor	Not set	Set
	5	-	-	-
	6	PSU Thermistor	Not high	High
15	Mail Box 1			
	0	Tray 1 Paper Overflow Sensor	Not full	Full
	1	Tray 1 Paper Sensor	Paper not detected	Paper detected
	2	Tray 2 Paper Overflow Sensor	Not full	Full
	3	Tray 2 Paper Sensor	Paper not detected	Paper detected
	4	Tray 3 Paper Overflow Sensor	Not full	Full
	5	Tray 3 Paper Sensor	Paper not detected	Paper detected
	6	Tray 4 Paper Overflow Sensor	Not full	Full
	7	Tray 4 Paper Sensor	Paper not detected	Paper detected

SP5-803 -XXX	Bit	Description	Reading	
			0	1
16	Mail Box 2			
	0	Vertical Transport Sensor 1	Paper not detected	Paper detected
	1	Vertical Transport Sensor 2	Paper not detected	Paper detected
	2	Door Safety Switch	Opened	Closed

Table 1: Paper Height Sensor

Low: Deactivated, High: Activated (actuator inside sensor)

Remaining paper	Paper height sensor 1	Paper height sensor 2
Full	Low	Low
Nearly full	Low	High
Near end	High	High
Almost empty	High	Low

Table 2: Paper Size Switch (Tray 2)

0: Not pushed, 1: pushed

Models		Switch Location			
North America	Europe/Asia	1	2	3	4
11" x 17" SEF	11" x 17" SEF	0	1	0	0
A3 SEF	A3 SEF	1	0	1	0
8 1/2" x 14" SEF *1	B4 SEF *1	1	1	0	1
8 1/2" x 11" SEF *2	A4 SEF *2	0	1	1	0
11" x 8 1/2" LEF *3	11" x 8 1/2" LEF *3	1	0	1	1
A4 LEF	A4 LEF	0	1	0	1
B5 LEF	B5 LEF	0	0	1	0
A5 LEF	A5 LEF	0	0	0	1

1: Pushed

NOTES:

*1: The machine detects either 8 1/2" x 14" SEF or B4 SEF, depending on the setting of SP 1-902-2

*2: The machine detects either 8 1/2" x 11" SEF or A4 SEF, depending on the setting of SP 1-902-3

*3: The machine detects either 11" x 8 1/2" LEF or B5 SEF, depending on the setting of SP 1-902-4

Table 3: Paper Size (By-pass Table)

Models		Bit No.			
North America	Europe/Asia	4	3	2	1
11" x 17" SEF	11" x 17" SEF	0	0	1	1
A3 SEF	A3 SEF	0	0	0	1
-	B4 SEF	0	0	1	0
8 1/2" x 11" SEF	A4 SEF	0	1	1	0
8" x 13" SEF	F SEF	0	1	0	0
-	A5 SEF	1	1	0	0
5 1/2" x 18 1/2" SEF	B6 SEF	1	0	0	0
Post Card	Post Card	0	0	0	0

5.3.3 OUTPUT CHECK TABLE

CH: Charge
 PF: Paper Feed
 TS: Toner Supply
 CW: Clockwise
 CCW: Counterclockwise
 MB: 4-bin Mailbox
 DI: Duplex Inverter

SP5-804-XXX		Description
7	Regist CL	Registration Clutch
8	By-pass CL	By-pass Feed Clutch
9	Tray 1 PF CL	Tray 1 Paper Feed Clutch
10	Pick-up SOL	By-pass Pick-Up Solenoid
11	Tray 2 PF CL	Tray 2 Paper Feed Clutch
12	Lift M UP (1)	Tray 1 Lift Motor / UP
13	Lift M DOWN(1)	Tray 1 Lift Motor / DOWN
14	Lift M UP(2)	Tray 2 Lift Motor / UP
15	Lift M DOWN(2)	Tray 2 Lift Motor / DOWN
17	PSU Fan M	PSU Cooling Fan Motor
19	Fusing Fan M H	Fusing Fan Motor / High Speed
20	Fusing Fan M L	Fusing Fan Motor / Low Speed
21	Laser Fan H	Laser Optics Housing Cooling Fan Motor / High Speed
22	Laser Fan L	Laser Optics Housing Cooling Fan Motor / Low Speed
23	Junction SOL	Exit Junction Gate Solenoid
24	Oil Supply SOL	Oil Supply Unit Solenoid
29	K Dev CL	Development Unit Clutch - K
30	C Dev CL	Development Unit Clutch - C
31	M Dev CL	Development Unit Clutch - M
32	Y Dev CL	Development Unit Clutch - Y
34	Fusing Relay	Fusing Relay
35	Heat Lamp	Heating Roller Fusing Lamp
36	Pressure Lamp	Pressure Roller Fusing Lamp
44	CH DC [Y] 125	Charge DC Bias for Yellow / 125 mm/s
45	CH DC [M] 125	Charge DC Bias for Magenta / 125 mm/s
46	CH DC [C] 125	Charge DC Bias for Cyan / 125 mm/s
47	CH DC [K] 125	Charge DC Bias for Black / 125 mm/s
48	CH AC [YMC]125	Charge AC Bias for Color / 125 mm/s
49	CH AC [K] 125	Charge AC Bias for Black / 125 mm/s
50	DevDC [Y]	Development DC Bias for Yellow
51	DevDC [M]	Development DC Bias for Magenta
52	DevDC [C]	Development DC Bias for Cyan
53	DevDC [K]	Development DC Bias for Black
54	DevAC [YMC]	Development AC Bias for Color
55	DevAC [K]	Development AC Bias for Black
56	Transfer [Y]	Transfer Current for Yellow
57	Transfer [M]	Transfer Current for Magenta
58	Transfer [C]	Transfer Current for Cyan
59	Transfer [K]	Transfer Current for Black

SP5-804-XXX		Description
60	Cleaning Bias	Transfer Belt Cleaning Roller Bias
51	PA Roller Bias	Paper Attraction Roller Bias
52	TS CL [Y]	Toner Supply Clutch for Yellow
63	TS CL [M]	Toner Supply Clutch for Magenta
64	TS CL [C]	Toner Supply Clutch for Cyan
65	TS CL [K]	Toner Supply Clutch for Black
67	Air Supply [Y]	Air Pump Motor and Valve for Yellow
68	Air Supply [M]	Air Pump Motor and Valve for Magenta
69	Air Supply [C]	Air Pump Motor and Valve for Cyan
70	Air Supply [K]	Air Pump Motor and Valve for Black
71	ID Sensor LED	ID Sensor LED
72	Drum M L CW	Drum Drive Motors (K & CMY) / Low Speed / Clockwise
23	Drum M M CW	Drum Drive Motors (K & CMY) / Middle Speed / Clockwise
74	Drum M H CW	Drum Drive Motors (K & CMY) / High Speed / Clockwise
75	PF M L CW	Paper Feed Motor / Low Speed / Clockwise
76	PF M M CW	Paper Feed Motor / Middle Speed / Clockwise
77	PF M H CW	Paper Feed Motor / High Speed / Clockwise
78	PF M Feed	Paper Feed Motor / Feed Speed / Clockwise
79	TD Vcnt	TD Sensor / Vcnt
80	CH AC[YMC]62.5	Charge AC Bias for Color - 62.5
81	CH AC [K]62.5	Charge AC Bias for Black - 62.5
82	CH AC [YMC]185	Charge AC Bias for Color - 185
83	CH AC [K]185	Charge AC Bias for Black - 185
84	Dev AC[YMC]62.5	Development AC Bias for Color - 62.5
85	Dev AC[K]62.5	Development AC Bias for Black - 62.5
86	Dev AC[YMC]185	Development AC Bias for Color - 185
87	Dev AC[K]185	Development AC Bias for Black - 185
91	PA Roller Bias	Paper Attraction Roller Bias
92	Memory Chip	Memory Chip / Power (5V) Supply
97	Belt M CW	Transfer Belt Contact Motor / Clockwise
98	Belt M CCW	Transfer Belt Contact Motor / Counterclockwise
99	Belt M Break	Transfer Belt Contact Motor / Break
120	PF CL PFU(3)	Paper Feed Clutch / Paper Feed Unit / Tray 3
121	PF CL PFU(4)	Paper Feed Clutch / Paper Feed Unit / Tray 4
122	Pick-upSOL LCT	Pick-up Solenoid / Large Capacity Tray
125	PFU M	Paper Feed Unit / Motor
128	Valve SOL [K]	Air Flow Valve solenoid for Black
129	Valve SOL [C]	Air Flow Valve solenoid for Cyan
130	Valve SOL [M]	Air Flow Valve solenoid for Magenta
131	Valve SOL [Y]	Air Flow Valve solenoid for Yellow
132	Air Pump M	Air Pump Motor
135	DevAC TRG[YMC]	Development AC Trigger for Color
136	DevAC TRG[K]	Development AC Trigger for Black
137	DevPWM TRG[K]	Development PWM Trigger for Black
138	DevPWM TRG[C]	Development PWM Trigger for Cyan
139	DevPWM TRG[M]	Development PWM Trigger for Magenta

SP5-804-XXX		Description
140	DevPWM TRG[Y]	Development PWM Trigger for Yellow
141	CHdcPWM TRG[K]	Charge DC PWM Trigger for Black
142	CHdcPWM TRG[C]	Charge DC PWM Trigger for Cyan
143	CHdcPWM TRG[M]	Charge DC PWM Trigger for Magenta
144	CHdcPWM TRG[Y]	Charge DC PWM Trigger for Yellow
145	CHac1 TRG[YMC]	Charge AC1 Trigger for Color
146	Chac2 TRG[YMC]	Charge AC2 Trigger for Color
147	Chac3 TRG[YMC]	Charge AC3 Trigger for Color
148	CHac1 TRG[K]	Charge AC1 Trigger for Black
149	Chac2 TRG[K]	Charge AC2 Trigger for Black
150	Chac3 TRG[K]	Charge AC3 Trigger for Black
151	MB M	4-bin Mailbox Main Motor
152	MB SOL1	4-bin Mailbox Junction Gate Solenoid 1
153	MB SOL2	4-bin Mailbox Junction Gate Solenoid 2
154	MB SOL3	4-bin Mailbox Junction Gate Solenoid 3
155	MB SOL4	4-bin Mailbox Junction Gate Solenoid 4
160	Duplex SOL	Duplex Junction Gate Solenoid
161	DI M1 62.5CCW	Duplex Inverter Motor 1 / 62.5 / Counterclockwise
162	DI M1 65CCW	Duplex Inverter Motor 1 / 65 / Counterclockwise
163	DI M1 125CCW	Duplex Inverter Motor 1 / 125 / Counterclockwise
164	DI M1 130CCW	Duplex Inverter Motor 1 / 130 / Counterclockwise
165	DI M1 185CCW	Duplex Inverter Motor 1 / 185 / Counterclockwise
166	DI M1 193CCW	Duplex Inverter Motor 1 / 193 / Counterclockwise
168	DI M1 370CCW	Duplex Inverter Motor 1 / 370 / Counterclockwise
169	DI M1 370CW	Duplex Inverter Motor 1 / 370 / Clockwise
170	DI M1 450CW	Duplex Inverter Motor 1 / 450 / Clockwise
171	DI M2 62.5CCW	Duplex Inverter Motor 2 / 62.5 / Counterclockwise
172	DI M2 65CCW	Duplex Inverter Motor 2 / 65 / Counterclockwise
173	DI M2 125CCW	Duplex Inverter Motor 2 / 125 / Counterclockwise
174	DI M2 130CCW	Duplex Inverter Motor 2 / 130 / Counterclockwise
174	DI M2 185CCW	Duplex Inverter Motor 2 / 185 / Counterclockwise
176	DI M2 193CCW	Duplex Inverter Motor 2 / 193 / Counterclockwise
178	DI M2 370CCW	Duplex Inverter Motor 2 / 370 / Counterclockwise
179	DI M2 370CW	Duplex Inverter Motor 2 / 370 / Clockwise
180	DI M2 450CW	Duplex Inverter Motor 2 / 450 / Clockwise
181	DI M12 62.5CCW	Duplex Inverter Motor 1&2 / 62.5 / Counterclockwise
182	DI M12 65CCW	Duplex Inverter Motor 1&2 / 65 / Counterclockwise
183	DI M12 125CCW	Duplex Inverter Motor 1&2 / 125 / Counterclockwise
184	DI M12 130CCW	Duplex Inverter Motor 1&2 / 130 / Counterclockwise
185	DI M12 185CCW	Duplex Inverter Motor 1&2 / 180 / Counterclockwise
186	DI M12 193CCW	Duplex Inverter Motor 1&2 / 193 / Counterclockwise
188	DI M12 370CCW	Duplex Inverter Motor 1&2 / 370 / Counterclockwise
189	DI M12 370CW	Duplex Inverter Motor 1&2 / 370 / Clockwise
190	DI M12 450CW	Duplex Inverter Motor 1&2 / 450 / Clockwise
193	Duplex M125CCW	Duplex Feed Motor / 125 / Counterclockwise
197	Duplex M230CCW	Duplex Feed Motor / 230 / Counterclockwise
198	Duplex M370CCW	Duplex Feed Motor / 370 / Counterclockwise

SP5-804-XXX		Description
202	DI M2 OFF	Duplex Inverter Motor 2 / OFF
204	K Dev M H	Development Motor - K / High Speed
205	K Dev M M	Development Motor - K / Middle Speed
206	K Dev M L	Development Motor - K / Low Speed
207	Color Dev M H	Development Motor - YMC / High Speed
208	Color Dev M M	Development Motor - YMC / Middle Speed
209	Color Dev M L	Development Motor - YMC / Low Speed
210	Polygon M 29	Polygon Motor / 29.528
211	Polygon M 21	Polygon Motor / 21.850
212	LD FC[K]62.5	LD Power for Black in Color Mode / 62.5
213	LD FC[K]125	LD Power for Black in Color Mode / 125
214	LD FC[Y]62.5	LD Power for Yellow in Color Mode / 62.5
215	LD FC[Y]125	LD Power for Yellow in Color Mode / 125
216	LD FC[M]62.5	LD Power for Magenta in Color Mode / 62.5
217	LD FC[M]125	LD Power for Magenta in Color Mode / 125
218	LD FC[C]62.5	LD Power for Cyan in Color Mode / 62.5
219	LD FC[C]125	LD Power for Cyan in Color Mode / 125
220	LD1 [K] 62.5	LD1 Power for Black / 62.5
221	LD1 [K] 125	LD1 Power for Black / 125
222	LD1 [K] 185	LD1 Power for Black / 185
223	LD2 [K] 62.5	LD2 Power for Black / 62.5
224	LD2 [K] 125	LD2 Power for Black / 125
225	LD2 [K] 185	LD2 Power for Black / 185
226	LD [K]62.5	LD Power for Black / 62.5
227	LD [K]125	LD Power for Black / 125
228	LD [K]185	LD Power for Black / 185

5.3.4 TEST PATTERN (SP5-997)

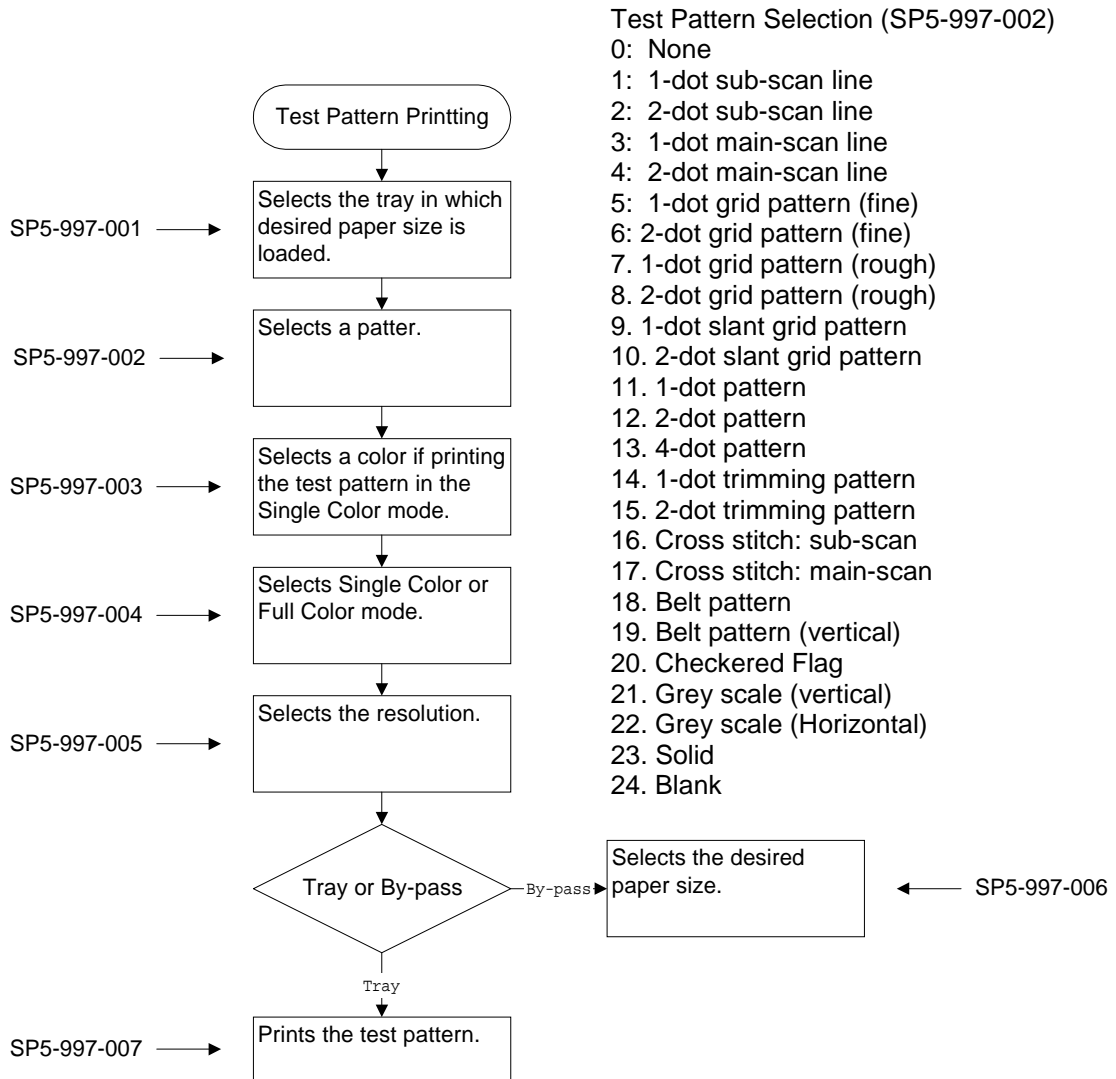

5.4 FIRMWARE UPDATE PROCEDURE

5.4.1 TYPE OF FIRMWARE

There are four types of firmware as shown below.

Type of firmware		Function	Number of IC cards required
Printer Engine	1. Main	Printer engine control	1 card
	2. MUSIC	Line position adjustment	1 card
Printer Controller	3. System	Printer system firmware	2 cards
	4. NIB	NIB firmware	1 card

Refer to “5.4.3 Controller/Engine Firmware Upgrade for the procedure.

NOTE: When upgrading all four types of firmware at the same time, you can upgrade them in any order.

However, when upgrading the controller system firmware, use the cards in the correct order (see below).

Two IC cards are needed to upgrade the controller system firmware. One IC card is for the operating system (Cardpf.swab), and the other is for the printer application (Cardprinter.swab). Always upgrade the operating system first, then the printer application next.

5.4.2 ERROR RECOVERY

Engine Firmware/Controller NIB Firmware

If a download attempt failed, try downloading the new firmware again using the procedure described in section 5.4.3.

Controller System Firmware:

If a download attempt failed, you must boot up the machine from the IC card. To do this, DIP SW 1 on the controller board needs to be ON. The machine automatically starts upgrading the firmware.

5.4.3 CONTROLLER/ENGINE FIRMWARE UPGRADE

⚠ CAUTION

- 1. Turn off the main switch whenever inserting or removing IC card.**
- 2. Do not turn off the machine while downloading the firmware.**

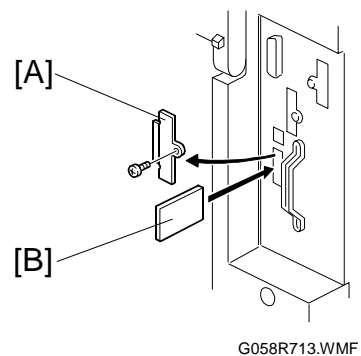
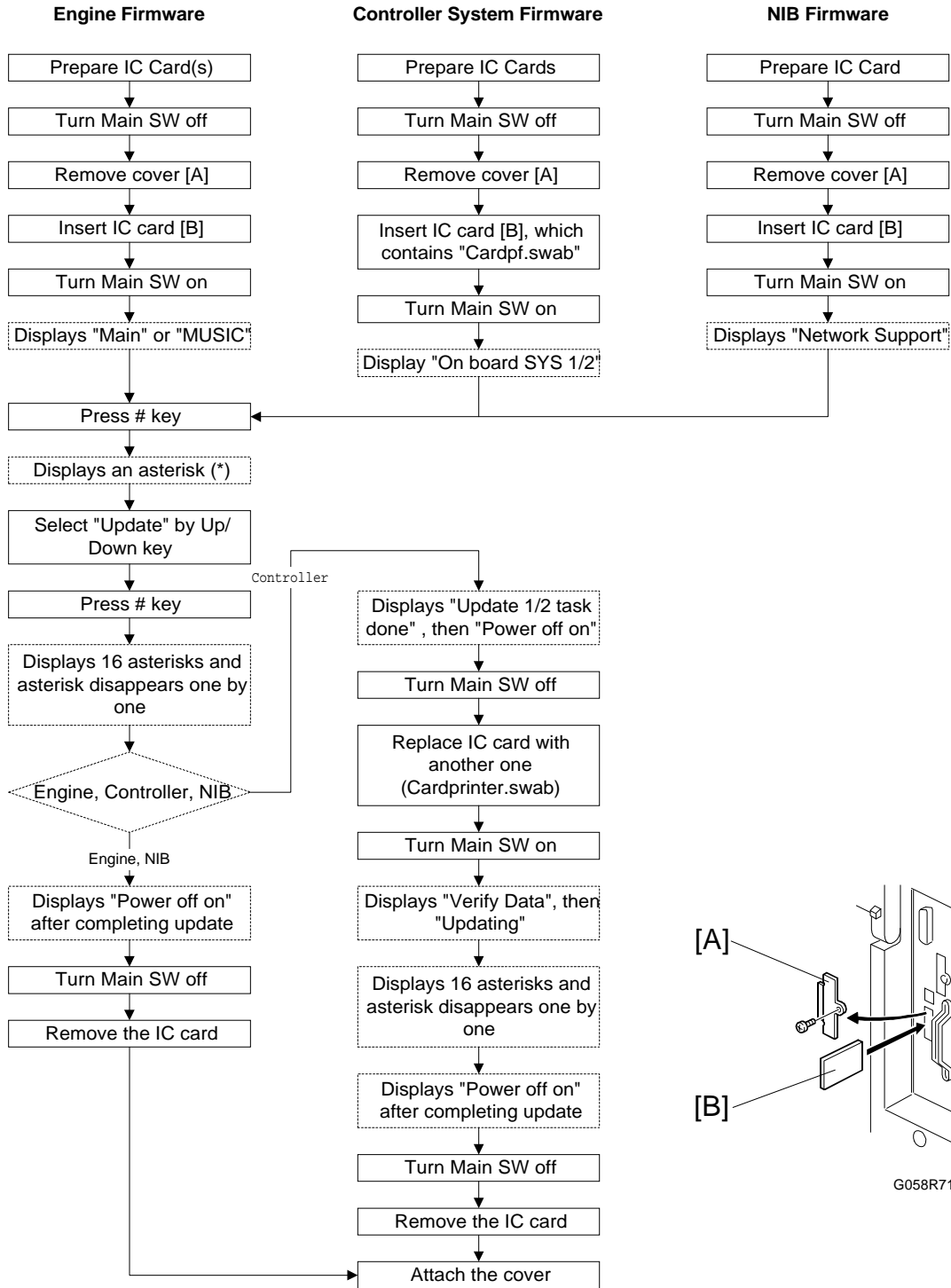

Service Tables

5.5 CONTROLLER SELF-DIAGNOSTICS

5.5.1 OVERVIEW

There are three types of self-diagnostics for the controller.

- Power-on self-diagnostics: The machine automatically starts the self-diagnostics just after the power has been turned on.
- Detailed self-diagnostics: The machine does the detailed self-diagnostics by using a loop-back connector (P/N G0219350)
- SC detection: The machine automatically detects SC conditions at power-on or during operation.

The following shows the workflow of the power-on and detailed self-diagnostics.

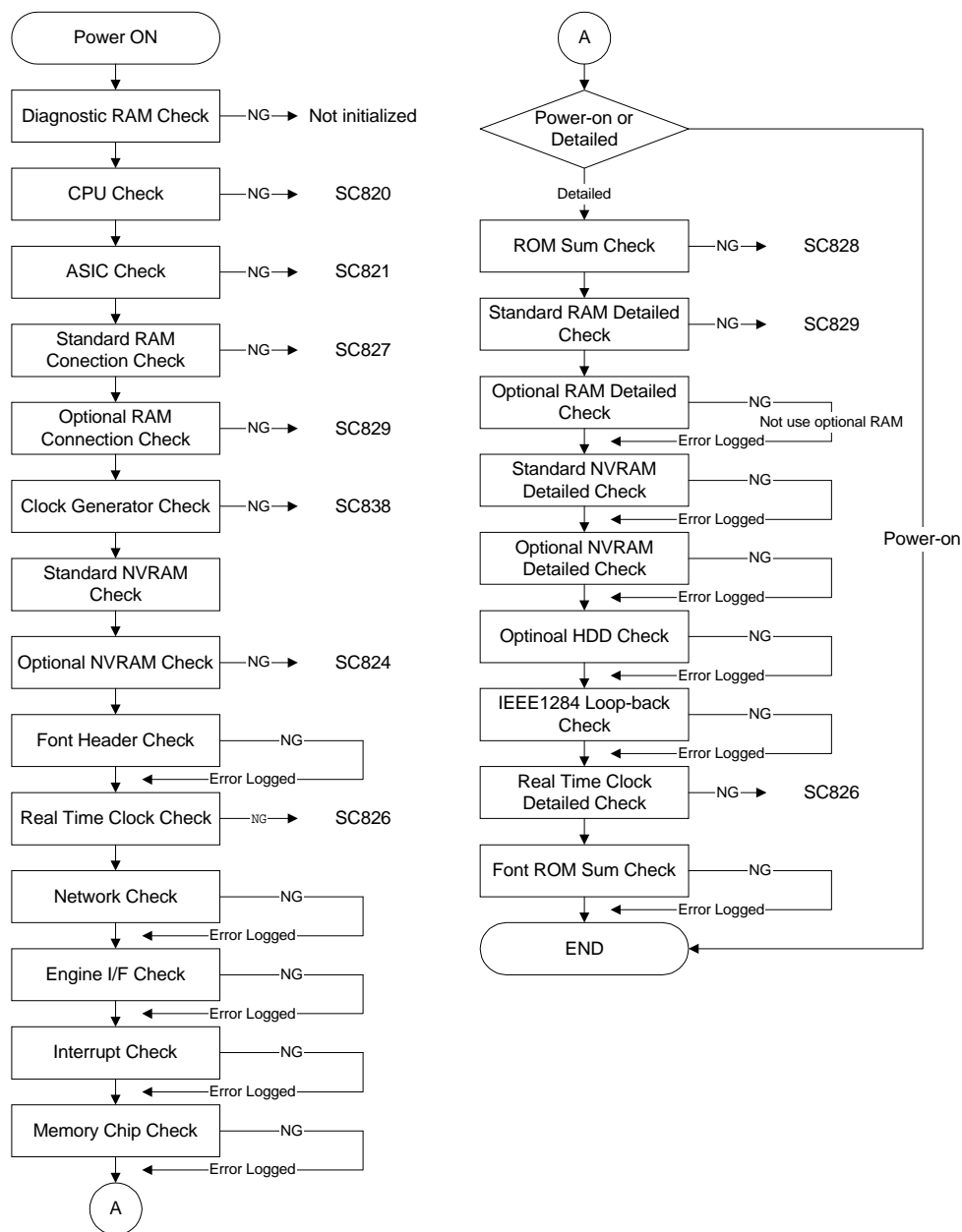

5.5.2 DETAILED SELF-DIAGNOSTICS

This detailed self-diagnostic test requires a loop-back connector (P/N: G0219350).

1. Turn off the machine and attach the loop-back connector to the parallel interface.
2. Turn on the machine while pressing the “On Line” key and “# Enter” key together.
3. The machine automatically starts the self-diagnostics and prints the diagnostic report after completing the test.
 - Refer to the diagnostics report for the detected errors. The errors detected during self-diagnostics can be checked with SP7-832-001 (Diag. Result).
 - Refer to section 4.2 for details about the error codes.

5.6 USER PROGRAM MODE

Press the “Menu” button and use the “Up/Down arrow” keys to scroll through the menu listing. To go back to a higher level, press the “Escape” key. After changing the settings, press the “On Line” key. The user menu list can be printed using “Menu List” in the “List/Test Print” user mode.

User Mode Tree

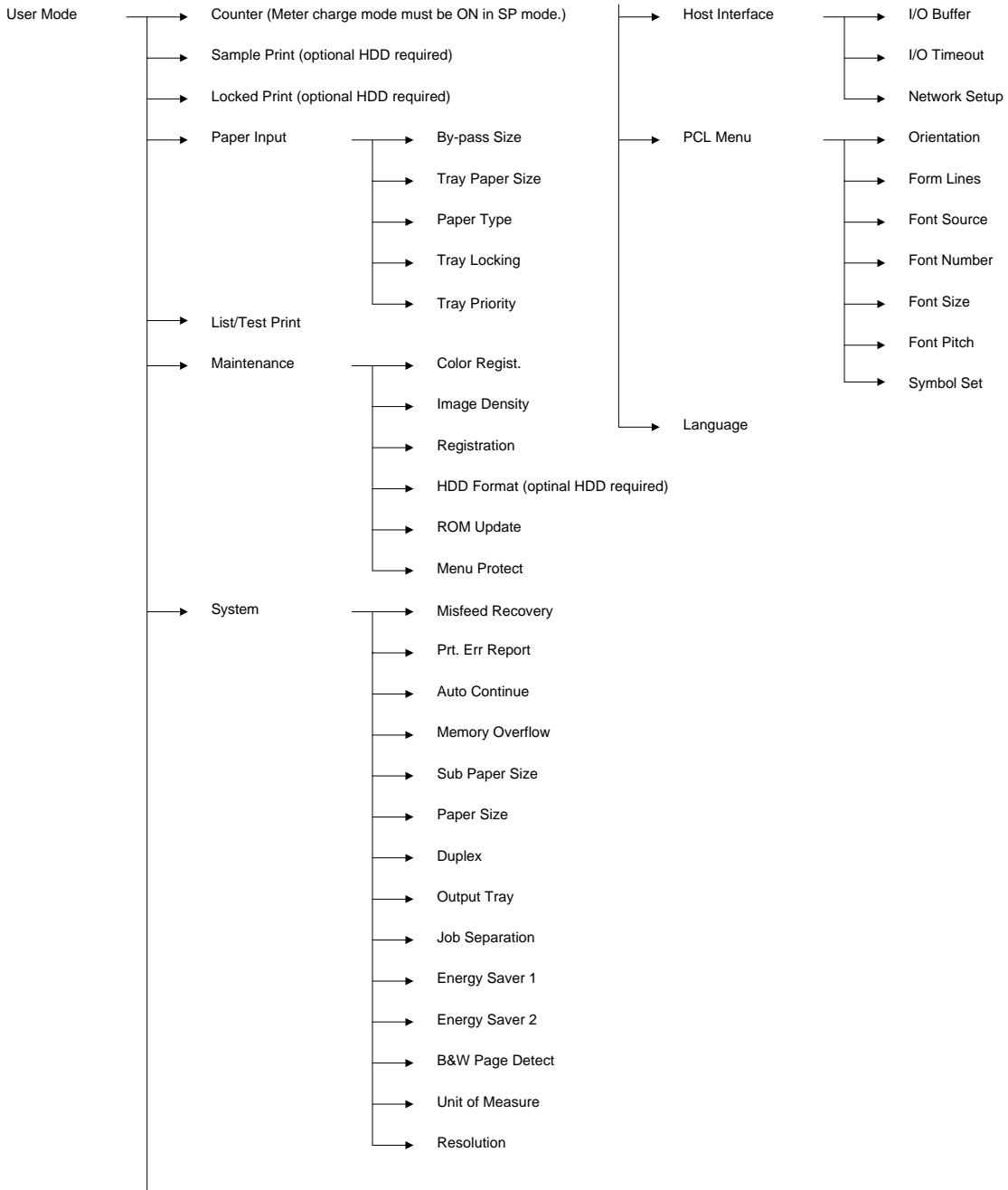

5.7 DIP SWITCHES

Controller Board

DIP SW No.	OFF	ON
1	Boot-up from flash ROM	Boot-up from IC card
2 to 4	Factory Use Only: Keep these switches OFF.	

NOTE: If a download attempt failed, you must boot up the machine from the IC card. To do this, DIP SW 1 on the controller board needs to be ON.

6. DETAILED SECTION DESCRIPTIONS

6.1 OVERVIEW

6.1.1 COMPONENT LAYOUT

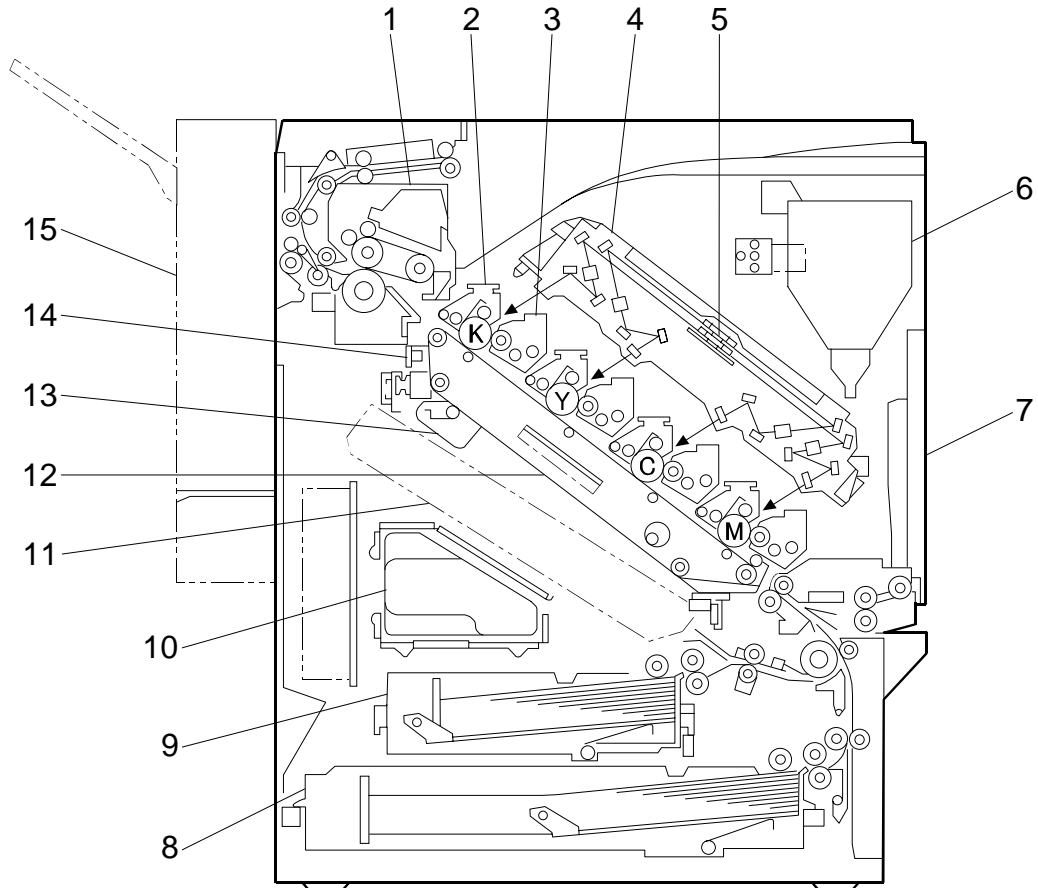

G060D153.WMF

- | | |
|------------------------------|---------------------------------|
| 1. Fusing Unit | 9. Tray 1 |
| 2. PCU (one for each color) | 10. Waste Toner Bottle |
| 3. Development Unit | 11. Duplex Feed Unit |
| 4. Laser Optics Housing Unit | 12. Transfer Unit |
| 5. Polygon Mirror Motor | 13. Transfer Belt Cleaning Unit |
| 6. Toner Cartridge | 14. ID Sensor |
| 7. By-pass Feed Table | 15. Duplex Inverter Unit |
| 8. Tray 2 | |

Detailed Descriptions

6.1.2 PAPER PATH

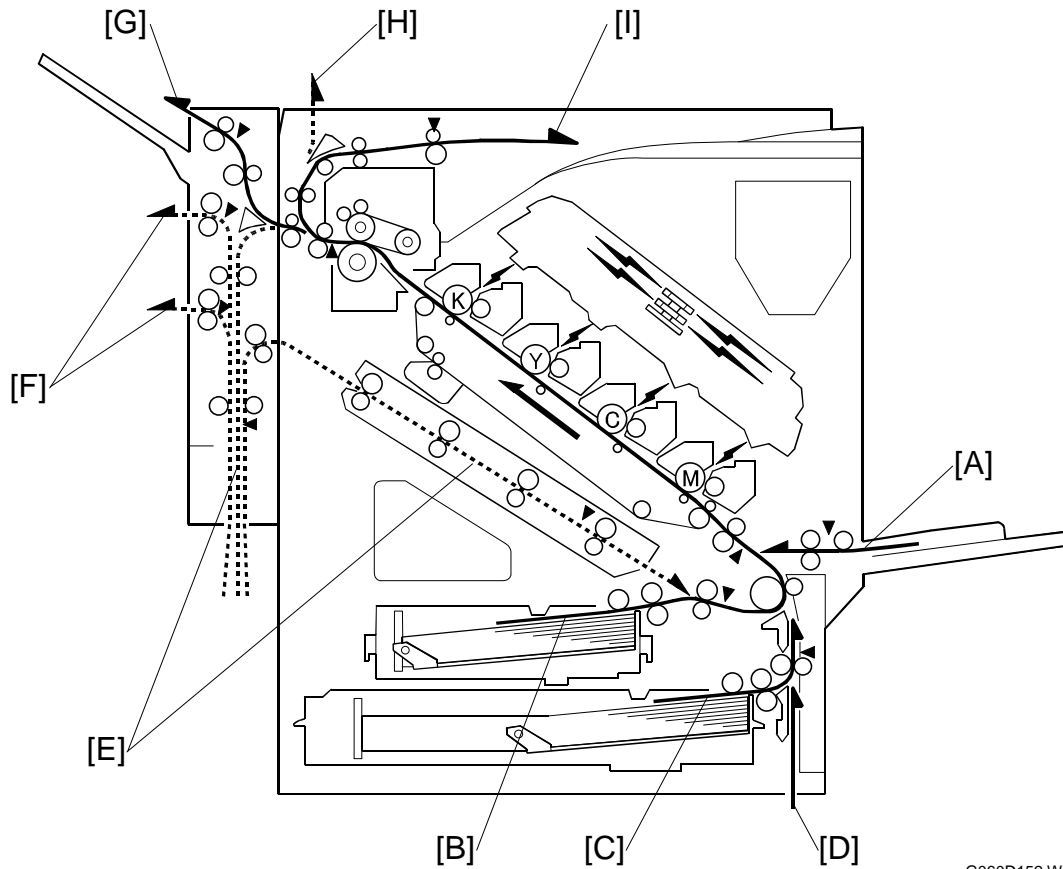

G060D152.WMF

- [A]: By-pass Feed Table
- [B]: Tray 1
- [C]: Tray 2
- [D]: Optional 1 Tray Paper Feed Unit, 2 Tray Paper Feed Unit, or LCT
- [E]: Optional Duplex Unit
- [F]: Optional Two-tray Finisher
- [G]: External Tray
- [H]: Optional Four-bin Mailbox
- [I]: Standard Tray (Internal Tray)

The two-tray finisher requires the duplex unit, and either the one-tray paper feed unit, two-tray paper feed unit, or LCT. It also requires the HDD or additional memory DIMM (total 128MB or more).

The duplex unit has two exits for the two-tray finisher. When the one-tray paper feed unit is installed, paper feeds out to the two-tray finisher from the upper exit. When the two-tray paper feed unit or LCT is installed, paper feeds out to the two-tray finisher from the lower exit.

6.1.3 DRIVE LAYOUT

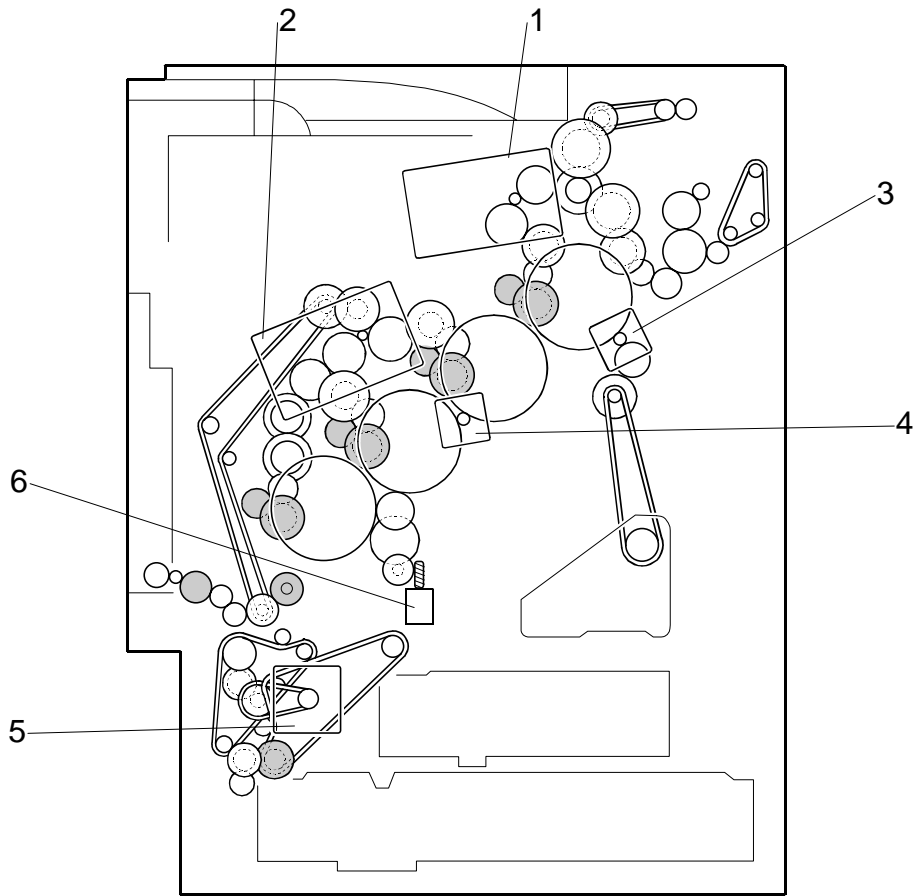

G060V901.WMF

1. Development drive motor-K
This drives the development unit for black, the fusing unit, and the paper exit section.
2. Development drive motor-CMY
This drives the development units for magenta, cyan, and yellow, and the registration roller and by-pass feed mechanism, and the waste toner collection coils from the PCUs.
3. Drum drive motor-K
This drives the PCU for black, the collection coil in the waste toner bottle, and the transfer unit.
4. Drum drive motor-CMY
This drives the PCUs for magenta, cyan, and yellow.
5. Paper feed motor
This drives the paper feed mechanisms for tray 1 and 2.
6. Transfer belt contact motor
This moves the transfer belt into contact and away from the color PCUs.

6.1.4 BOARD STRUCTURE

Overview

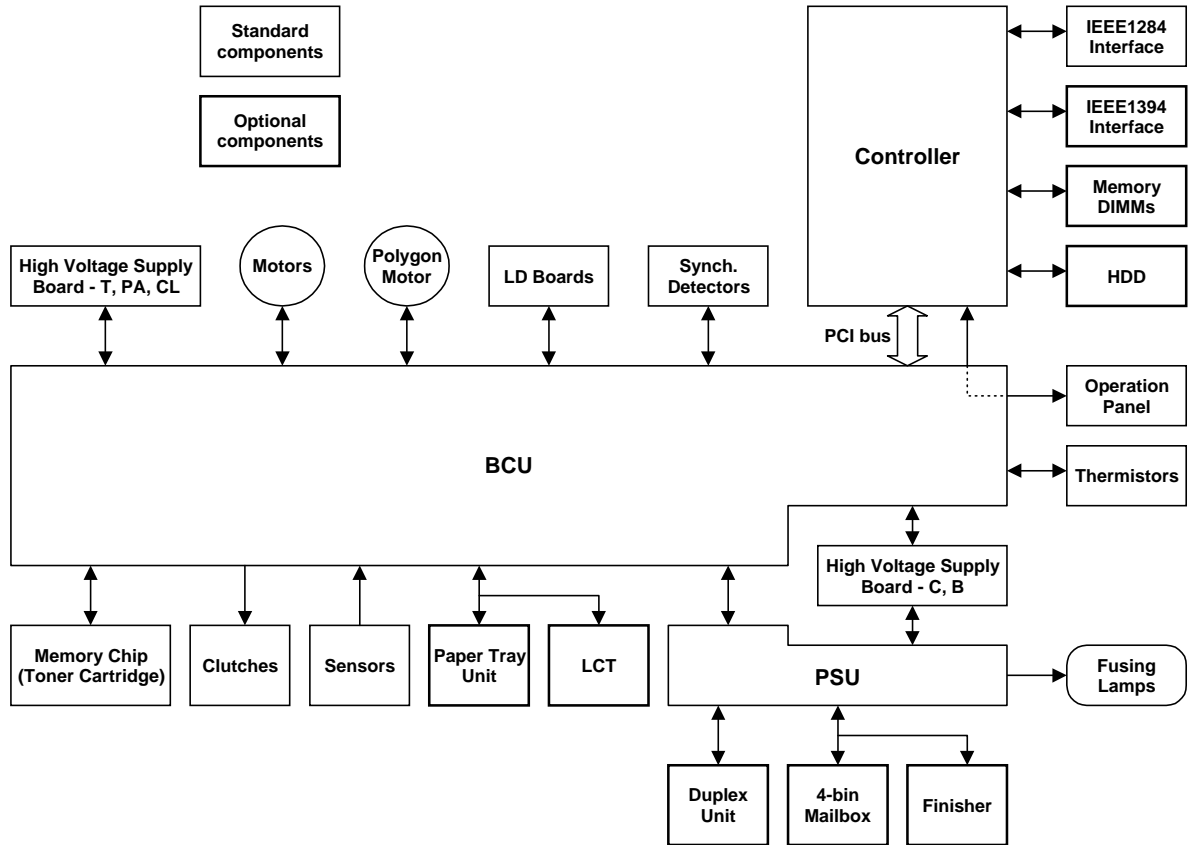

G060D551.WMF

The BCU controls all the mechanical components. The IEEE1394 interface board, memory DIMM, and the HDD can be installed on the controller.

The controller connects to the BCU through a PCI bus.

Descriptions

1. BCU (Base Engine Control Unit)

The BCU has two CPUs (Main and MUSIC). The CPUs control the following functions:

- Main CPU
 - Engine sequence
 - Machine and printer engine operation
 - Timing for peripherals
 - High voltage supply, laser, and fusing
 - Sensors, motors, and solenoids
- MUSIC (Mirror Unit for Skew and Interval Correction) CPU
 - TD sensor
 - Line position adjustment
 - Memory chip on the toner cartridge

2. Controller

The controller handles the following functions:

- Printer-to-host interface
- Operation panel interface
- Network interface
- Interfacing and control of the optional IEEE1394, HDD and DRAM DIMM

3. LD Drive Board

This is the laser diode drive circuit board.

4. IEEE1394 Interface (Option)

This allows computers to connect to this printer using an IEEE1394 interface.

5. HDD Unit (Option)

The HDD unit stores the data for the following.

- Additional soft fonts
- Collation
- Locked print
- Sample print
- Downloading forms for form overlay

6. Memory DIMM (Standard: 32MB DRAM, Option: 64/128/256MB DRAM)

This is for additional printer processing memory, used for collation and for soft fonts.

7. Operation Panel Board

Controls the display panel, the LED, and the keypad.

8. IEEE1284 Interface

This is a parallel printer port.

6.1.5 PRINTING PROCESS

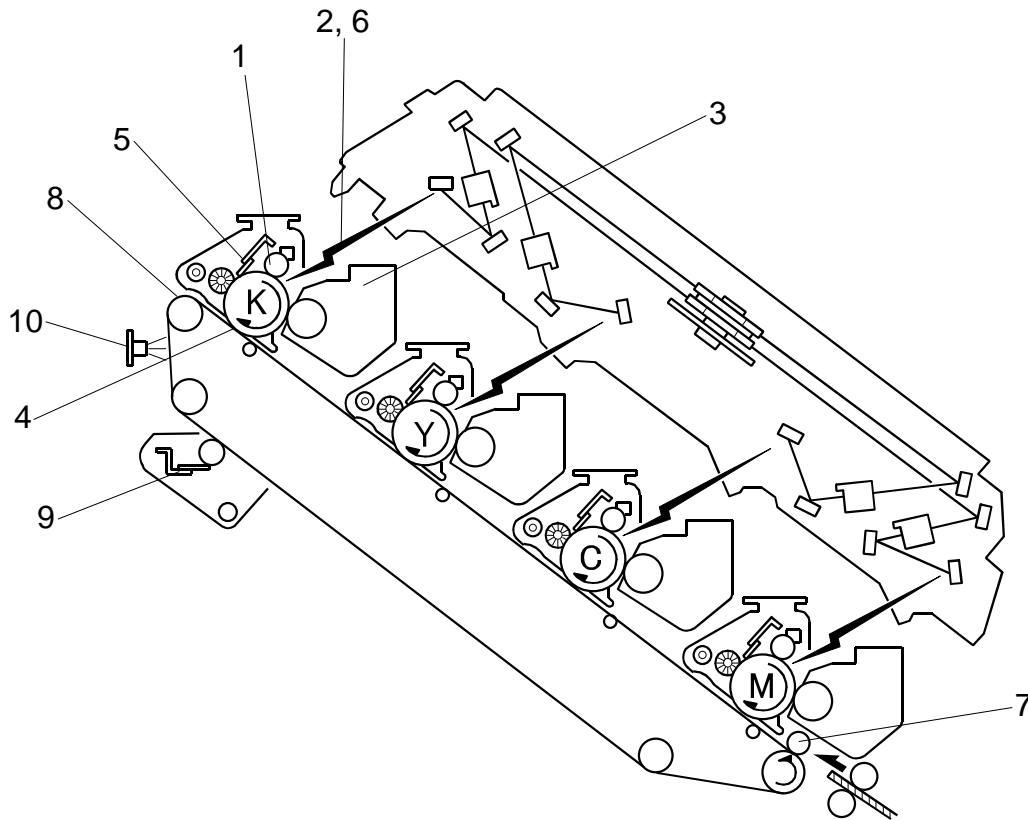

G060D151.WMF

This machine uses four PCUs, four development units, and four laser beams for color printing. Each PCU consists of a drum, charge roller, cleaning brush, and blade. From the left, the PCU stations are black, yellow, cyan, and magenta.

A transfer belt feeds paper past the PCUs, and the toner image on each drum is transferred to the paper.

The paper path is inclined about 38 degrees to make the machine as compact as possible.

- 1) Drum charge:
The charge roller gives the drum a negative charge
- 2) Laser exposure:
The laser beam from the laser diode (LD) goes through the lens and mirrors and reaches the drum. Turning the laser beam on and off, and creates a latent image on the drum.
- 3) Development:
The development roller carries negatively charged toner to the latent image on the drum surface. This machine uses four independent development units (one for each color).
- 4) Image transfer:
The charge applied to the transfer brush attracts the toner from the drum to the paper. Four toner images are super-imposed onto the paper.
- 5) Cleaning for OPC drum:
The cleaning brush and blade remove any toner remaining on the drum surface after image transfer to the paper.
- 6) Quenching for OPC drum:
Quenching is done by illuminating the whole area of the drum with the laser at the end of every job.
- 7) Paper attraction:
Paper is attracted to the transfer belt by the charge applied to the paper attraction roller.
- 8) Separation:
Paper separates from the transfer belt when the belt curves away from it.
- 9) Cleaning and quenching for transfer belt:
The cleaning roller cleans the belt surface. The grounding roller inside the transfer belt unit removes the remaining charge on the belt.
- 10) ID sensor:
The ID sensor board contains two ID sensors (one at the front, and one at the rear). The ID sensor detects the density of the ID sensor pattern on the transfer belt. The ID sensor output is used for process control and for automatic line position, skew, and color registration adjustments for the latent image.

6.2 PROCESS CONTROL

6.2.1 OVERVIEW

This machine provides the following two forms of process control:

- Potential control
- Toner supply control

The process control facilities of this machine have the following features:

- Two ID (image density) sensors (front and rear). Only the front ID sensor is used for process control. The front and rear ID sensors are used for line positioning and other adjustments.
- TD (toner density) sensor.

6.2.2 POTENTIAL CONTROL

Overview

Potential control controls development to maintain the density of the toner image on the drum. It does this by compensating for variations in drum chargeability and toner density.

The machine uses the ID sensor to measure the reflectivity of the transfer belt and the density of a standard sensor pattern. This is done during the process control self check.

The machine determines the following depending on the ID sensor output and a reference table in memory.

- VD: Drum potential without exposure – to adjust this, the machine adjusts the charge roller voltage.
- VB: Development bias
- VL: Drum potential at the strongest exposure – to adjust this, the machine adjusts the laser power

(In addition, VREF is corrected. This is used for toner supply control.)

This process controls the development potential so that the maximum amount of toner applied to the drum is constant. However, to control the development potential to improve reproduction of highlight parts of the image, the laser power control method can be changed. This depends on the setting of SP3-125-2. The default setting is 1 (normal control method). To change to the highlight range control method, set this SP to 2.

If SP3-125-1 is set to 0 (Off), the machine does not do the potential control, but uses the development bias adjusted with SP2-201-1 to -9, the charge roller voltage adjusted with SP2-001-1 to -9, and the laser power selected with SP2-103-1 to -27. However, these SPs should normally not be adjusted in the field.

Process Control Self Check

This machine carries out potential control using a procedure called the process control self check. There are seven types of process control self check, categorized according to their execution times.

1. **Forced**
This is done when SP3-126-1 is used.
2. **Initial**
This starts automatically when the power is turned on, but only if the fusing unit pressure roller temperature is less than 60°C.
3. **Interval: Job End**
This starts automatically at the end of a print job when the total print counter for this feature exceeds 200 (this can be changed with SP3-906-1). After any process control is done (except for forced process control), the counters are reset to 0.
4. **Interval: Interrupt (default: not done)**
This interrupts printing and then starts automatically when the machine makes a certain number (A) of continuous color prints in the same job. After it is completed, the machine continues to make prints.
The value A can be adjusted with SP3-906-2 (default: off).
At this time, only VREF is corrected. Potential control (VD, VB, VL correction) is not done.
5. **Non-use Time (default: not done)**
This starts before the next print job if the machine has no job for a certain time (M) after it makes more than a certain number (N) of prints.
M is adjusted with SP3-906-4 and N is adjusted with SP3-906-3.
6. **After Toner End Recovery**
This starts after recovery from a toner end condition.
7. **After Developer Initialization**
This starts after a developer initialization is done. Developer initialization occurs automatically after a new development unit has been installed.

6.2.3 PROCESS CONTROL SELF CHECK PROCEDURE

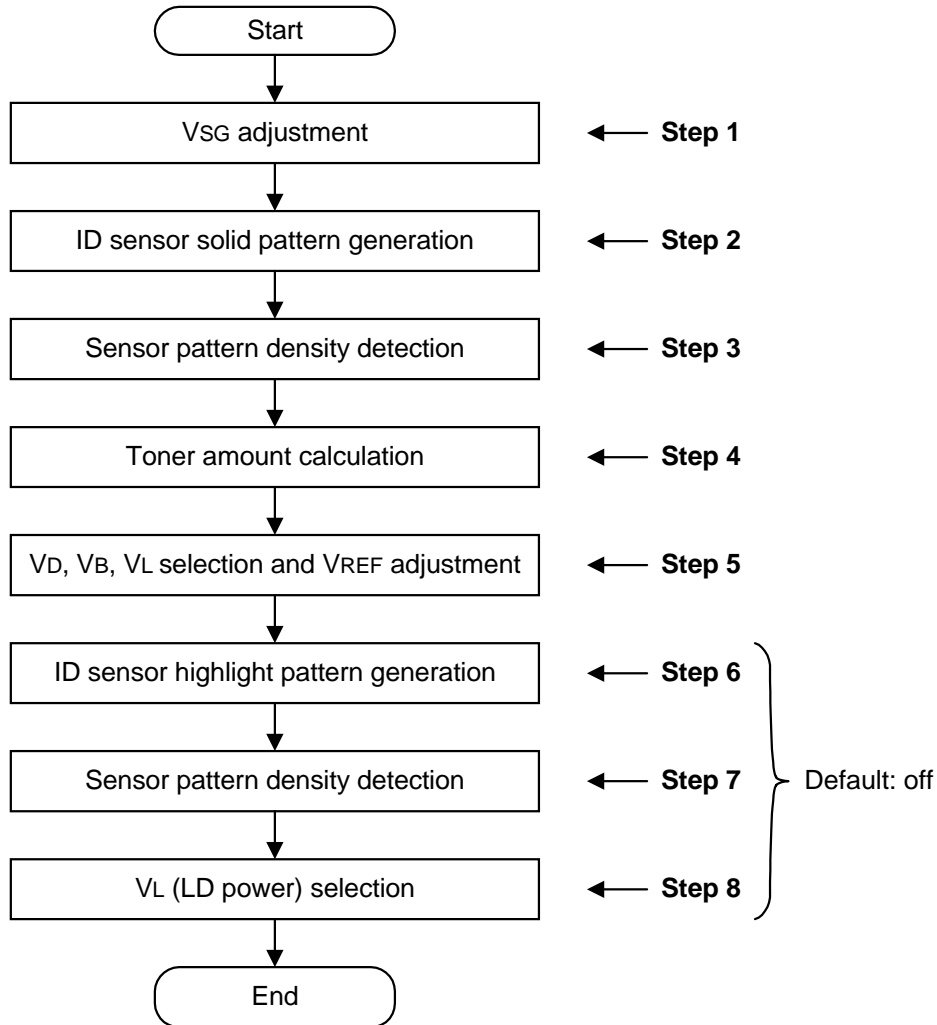

G060D052.WMF

Step 1: VSG Adjustment

This machine uses two ID sensors (direct reflection type). They are located at the front and rear of the transfer unit. Only the front ID sensor is used for process control. The ID sensor checks the bare transfer belt's reflectivity and the machine calibrates the ID sensor until its output (known as VSG) is as follows.

- VSG = 4.0 ± 0.5 Volts

This calibration compensates for the transfer belt's condition and the ID sensor condition, such as dirt on the surface of the belt or ID sensor.

Step 2: ID Sensor Solid Pattern Generation

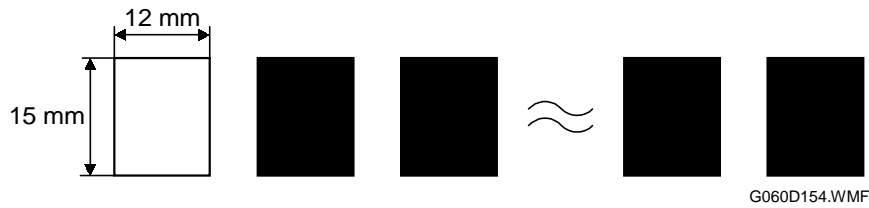

The machine agitates the developer for 15 seconds, and then makes a 10-grade pattern (12 mm x 15 mm) on the transfer belt for each toner color. Each grade of the pattern is a solid color, and is made by changing the development bias and charge roller voltage. The difference between development bias and charge roller voltage is always the same.

Step 3: Sensor Pattern Detection

The ID sensor detects the densities of the 10 solid patterns for each color. This data goes to memory.

Step 4: Toner Amount Calculation

The amount of toner on the transfer belt (M/A, mass per unit area, mg/cm²) is calculated for each of the 10 grades of the sensor pattern from the ID sensor output value from each grade of the pattern.

Step 5: VD, VB, VL Selection and VREF Adjustment

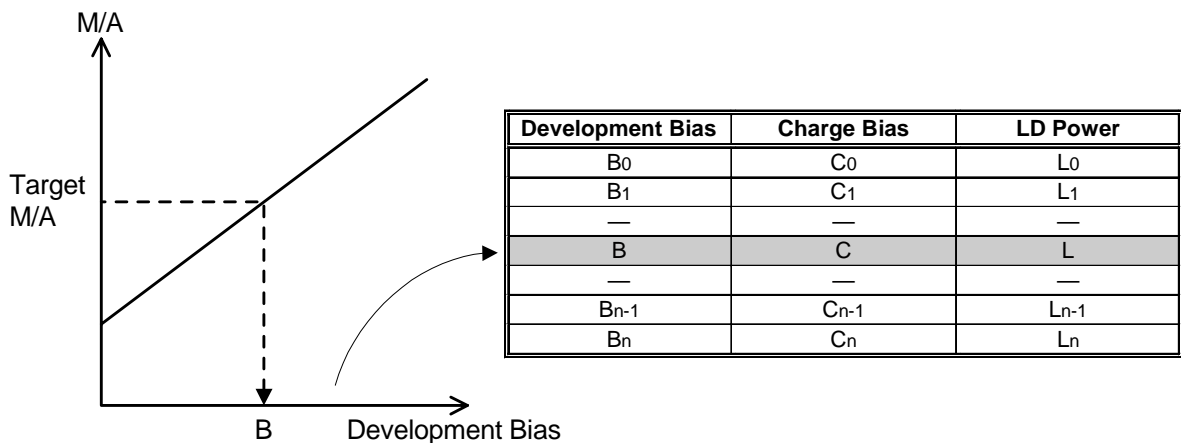

Detailed Descriptions

G060D002.WMF

The machine determines the relationship between the amount of toner on the transfer belt and the development bias for each of the 10 grades. The machine now selects the development bias and charge roller voltages for the target M/A for each color by referring to a table in memory.

The way that the laser power (VL) is selected depends on the setting of SP3-125-2.

- If it is set to 0, the LD power is fixed at the value of SP2-103-1, to -27.
- If it is set to 1, LD power is selected using the same memory table as mentioned above.
- If it is set to 2, LD power is determined by ID sensor highlight pattern generation (steps 6 to 8 later in this procedure).

The machine also adjusts VREF (toner density target) at the same time so that the development gamma detected by process control will be the value stored in SP3-120-1 to -4 (do not adjust in the field unless advised to do so).

After that, the machine cleans the transfer belt by applying a positive dc charge to the cleaning roller for three rotations of the belt. It does not use the cleaning blade.

Allowable changes to VD, VB, and VL as a result of process control:

This depends on the process control type as follows.

- Forced : No limit
- Initial, After Developer Initialization: ± 80 volts
- Interval (Job End/ Non-use Time/ During Toner End Recovery): ± 40 volts
- Interval (Interrupt): Constant (The memory table is not used.)

Steps 6 to 8 are carried out only if SP3-125-2 is set to 2. (Default: Steps 6 to 8 are not used)

Step 6: ID Sensor Highlight Pattern Generation



The machine makes a 10-grade (12 mm x 15 mm) on the transfer belt for each toner color. The patterns are dot patterns, not solid colors like for the process in step 2. Each grade of the pattern is made using the bias and charge roller voltages selected above, and the various grades are made by changing the LD power.

Step 7: Sensor Pattern Density Detection

The ID sensor detects the densities of the 10 patterns for each color. This data goes to memory.

Step 8: VL (LD Power) Selection

The machine determines the relationship between the amount of toner on the transfer belt and the laser power for each of the 10 grades. The machine now selects the laser power to get the target M/A.

After that, the machine cleans the transfer belt by applying a positive dc charge to the cleaning roller for three rotations of the belt. It does not use the cleaning blade.

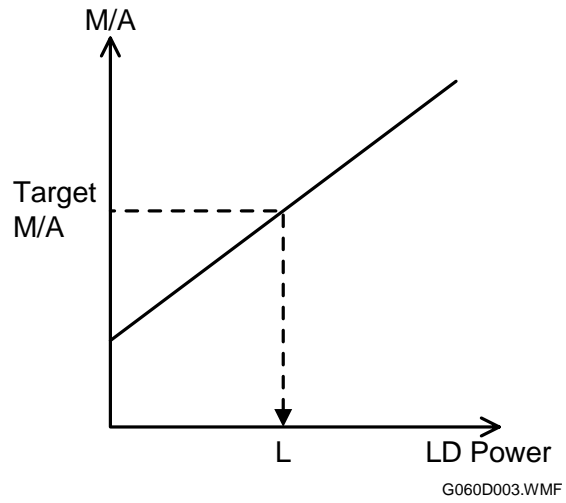

Detailed Descriptions

6.2.4 TONER SUPPLY CONTROL

Overview

Toner supply control uses the following to determine the amount of toner to be supplied. This is done before every development for each color.

- Density of the toner in the developer (as detected by the TD sensor) - VREF, VT
- Pixel count

The image density is kept constant by adjusting the density of toner in the development unit, while accommodating to changes in the development conditions through the potential control mechanism. Environmental changes and the number of prints made are also used in the calculation.

The amount of toner supplied is determined by the 'on' time of the toner supply clutch. The total 'on' time for each toner supply clutch is stored in the memory chip for the relevant toner cartridge. The amount of toner supplied also depends on the process line speed for the current job. The machine supplies the calculated amount of toner for each color.

Toner Supply Control Modes

This machine has three toner supply control modes. They are selected with SP2-208-1 to -4.

1. Fuzzy control mode
This is the default toner supply control mode. The TD sensor, ID sensor, and pixel count are used in this mode.
2. Proportional control mode
This mode is used when the ID sensor at the front becomes faulty. Only the TD sensor is used to control toner supply. The machine uses the VREF that is stored in SP2-224-5 to -8.
3. Fixed supply mode
This mode is used when the TD sensor becomes faulty. The amount of toner supply can be adjusted with SP2-208-5 to -8 if the image density is incorrect (the default setting is 5%).

6.2.5 TONER NEAR END/TONER END DETECTION

Introduction

The machine counts the toner supply clutch 'on' time and stores the total 'on' time in the memory chip located on each toner cartridge. The machine starts to monitor the toner near end condition when the toner remaining in the toner cartridge, which is calculated from the total 'on' time, becomes less than 100 g.

However, in certain conditions, toner end will be detected regardless of how much remaining toner is calculated. See the Note in Toner End Detection below.

Toner Near End Detection

The machine flags a "toner near end condition" when the following condition is detected for a toner color.

- $V_{REF} + 0.4 V < V_T$ (ten times consecutively)

Toner End Detection

The machine flags a "toner end condition" when one of the following conditions are detected for a toner color.

- $V_{REF} + 0.8 V < V_T$ (ten times consecutively)
- The pixel counter counts up the equivalent of 5 A4 sheets of pixels (100% coverage) since near-end was detected.

However, if fewer pages have been made since near-end than the number guaranteed with SP 2-212-11 (default: 10 pages), printing will continue.

NOTE: If one of the following conditions are detected 10 consecutive times, the machine flags a "toner end condition" regardless of the toner supply clutch 'on' time or the number of pages printed since near-end.

- $V_{REF} + 1.2 V < V_T$
- $V_T > 4.8 V$

After the machine detects toner end for black, it cannot print until the toner cartridge is replaced. If toner end is detected for cyan, magenta or yellow, the machine can print with black and white only; color printing is disabled.

Toner End Recovery

The machine detects that the toner cartridge has been replaced if the upper right cover is opened and closed when a near-end or end condition exists. The machine then starts to supply toner to the development unit. After supplying toner, the machine clears the toner end condition if the machine detects the proper V_T .

6.2.6 DEVELOPER INITIALIZATION

When the machine detects that a new development unit has been installed, it initializes the developer.

To do this, the machine agitates the developer for about 90 seconds, and adjusts VCNT (control voltage for TD sensor) so that VT (TD sensor output) becomes 3.0 ± 0.1 volts. The machine stores this VT as VREF.

V_{CNT} is corrected for the current humidity every print job. VCNT is also corrected for the total number of prints, to prevent the developer Q/M from varying.

If the humidity correction is giving poor results (for example, if the humidity sensor is broken), it can be disabled with SP2-223-2. Then a value for VCNT must be input manually using SP2-224-1 to -4 (adjust by trial and error).

During developer initialization, the machine forcibly supplies toner because there is no toner inside the toner transport tube at installation. Then the machine does the process control self check.

6.3 LASER EXPOSURE

6.3.1 OVERVIEW

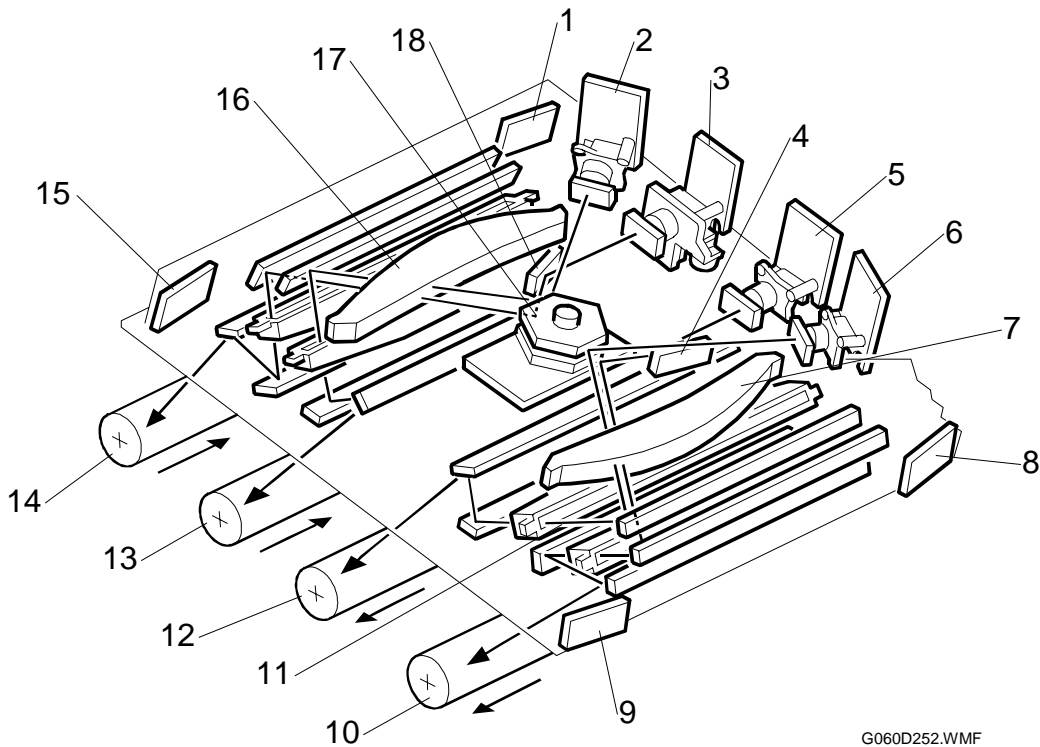

G060D252.WMF

- | | |
|--|---|
| 1. Synchronizing detector board-Y, K-E | 10. OPC drum-M |
| 2. LD unit-Y | 11. WTL |
| 3. LD unit-K | 12. OPC drum-C |
| 4. LD Mirror-M | 13. OPC drum-Y |
| 5. LD unit-M | 14. OPC drum- K |
| 6. LD unit-C | 15. Synchronizing detector board-Y, K-S |
| 7. F-theta lens-M, C | 16. F-theta lens-Y, K |
| 8. Synchronizing detector board-M, C-S | 17. Polygon mirror motor |
| 9. Synchronizing detector board-M, C-E | 18. LD Mirror-K |

Detailed Descriptions

This machine uses four LD units and one polygon mirror motor to produce a latent image on four OPC drums (one drum for each color toner).

There are two hexagonal mirrors. Each mirror reflects beams from two LD units. The LD unit for black has two laser diodes to do dual beam writing (this is only done for black-and-white printing; for full color printing, only one of the beams is used).

Laser exposure for magenta and cyan starts from the rear side of the drum, but for yellow and black it starts from the front side of the drum. This is because the units for magenta and cyan are on the other side of the polygon mirror from the units for yellow and black.

6.3.2 OPTICAL PATH

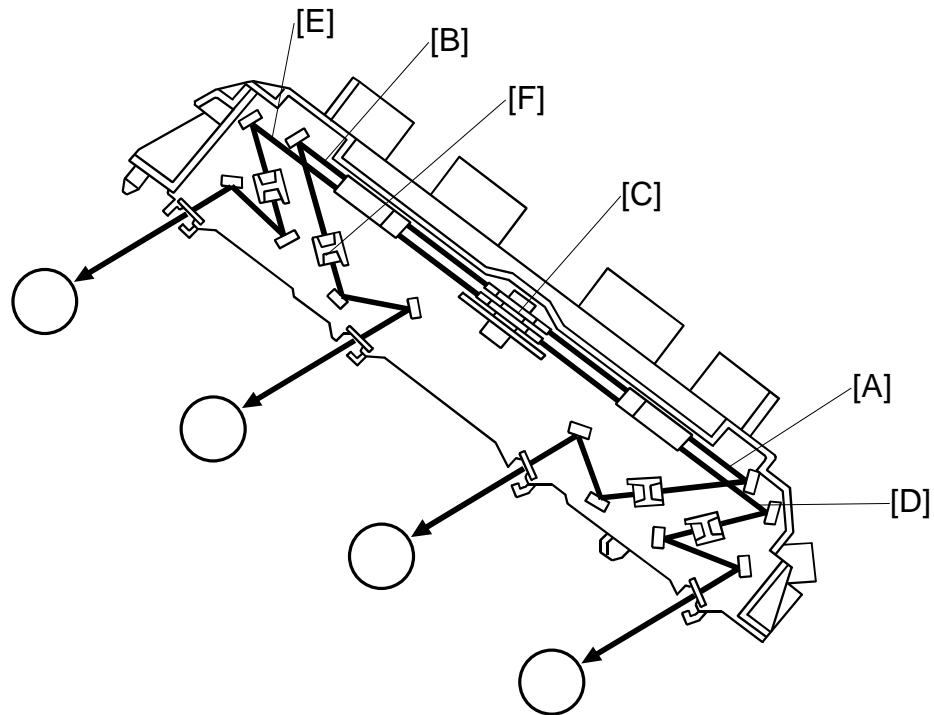

G060D201.WMF

The laser beams for cyan [A] and yellow [B] are directed to the upper part of the polygon mirror [C], and those for magenta [D] and black [E] are directed to the lower part of the polygon motor. The LD mirrors (see the previous page) deflect the laser beams for magenta and black towards the lower polygon mirror.

The WTL [F] corrects the main scan line; without this component, the line bends out towards the middle of the main scan. The central bend of the WTL is adjusted in the factory.

The speed of the polygon mirror depends on the selected mode (see below).

Mode	Resolution (dpi)	Polygon motor speed (rpm)	Process line speed (mm/s)	Print speed (ppm)	Remarks
B/W (except OHP/Thick paper)	600 x 600	21,850	185	38	Dual beam writing
	1,200 x 600				
Color (except OHP/Thick paper)	600 x 600	29,528	125	28	
	1,200 x 1,200				
OHP/Thick	600 x 600 1,200 x 600 1,200 x 1,200	29,528	62.5	10	

6.3.3 LASER SYNCHRONIZING DETECTOR

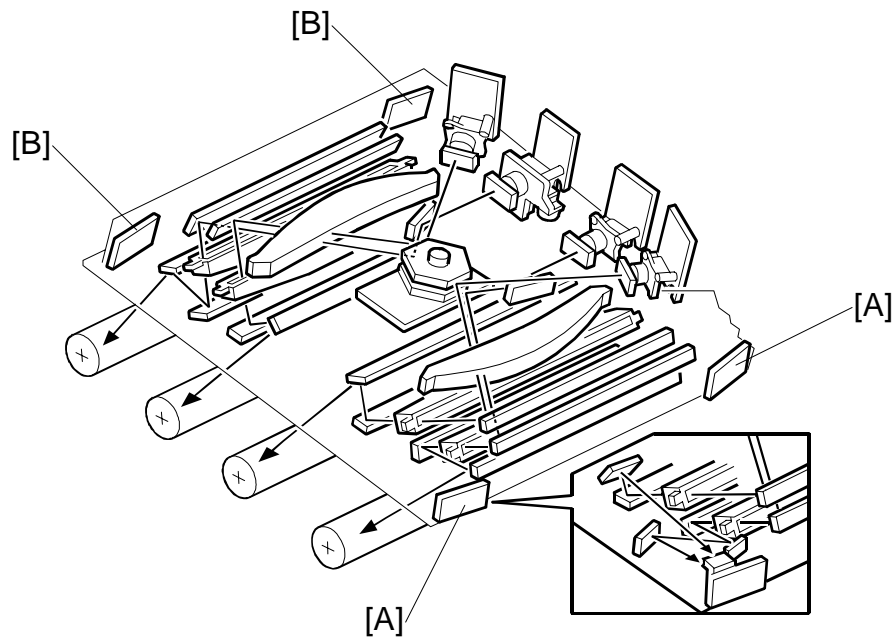

G060D202.WMF

Overview

The machine has four laser synchronizing detector boards (LSD), one at each corner of the laser optics housing unit.

Each pair of boards detects two colors. The machine recognizes each color from the time that they are detected. The two LSDs [A] at the right are used for magenta and cyan, and the two [B] at the left are used for yellow and black.

Main Scan Start Detection

For magenta and cyan, the LSD at the rear detects the start of the main scan. For yellow and black, the LSD at the front detects the start of the main scan.

Clock Frequency Adjustment

Each pair ensures that the number of laser clock pulses in the main scan is constant. If the count for one particular beam varies from normal, the LD clock frequency for that beam is adjusted.

If the board at the end position is defective, this cannot be detected. Switch the detection feature off with SP2-919-1.

6.3.4 DUAL BEAM WRITING

Dual Beam Mechanism

The LD unit for black has two laser diodes. Each face of the polygon mirror writes two main scan lines. This only happens for black and white printing.

Laser Beam Pitch Change Mechanism

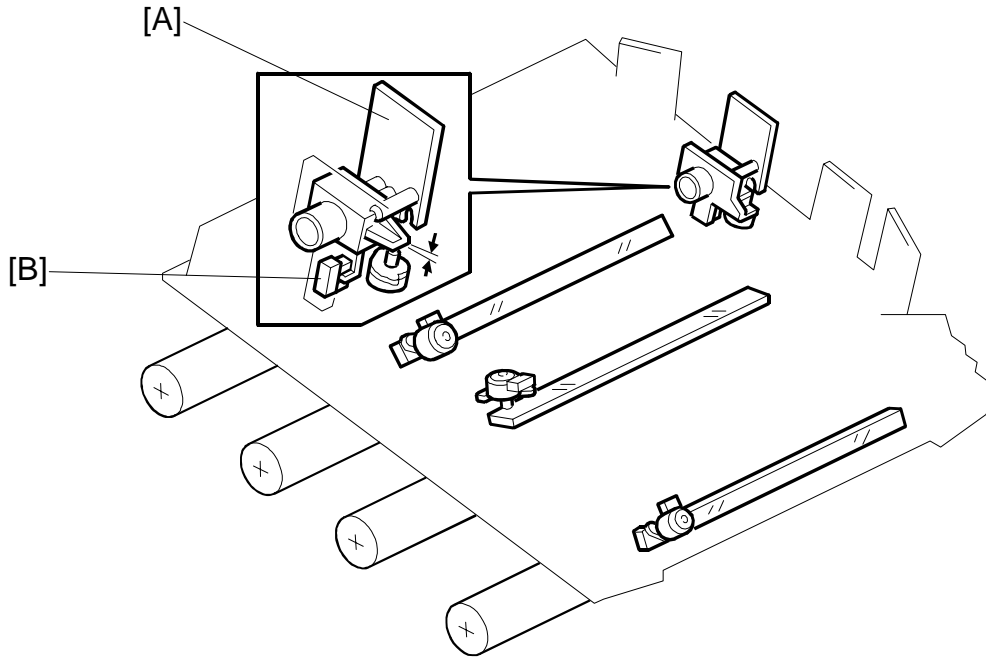

G060D253.WMF

The machine changes the main scan resolution between 600 and 1,200 dpi for black and white by rotating the LD unit [A], except for OHPs and thick paper.

Both LD unit positions are fixed distances from the LD home position sensor [B]. When the number of times that the resolution has changed reaches a certain number, the LD positioning motor moves the LD unit to the home position, and then to the proper position.

After the laser optics housing unit has been replaced, the beam pitch for 600 dpi and 1200 dpi must be adjusted (SP2-109-2, -3).

6.3.5 LD SAFETY SWITCH

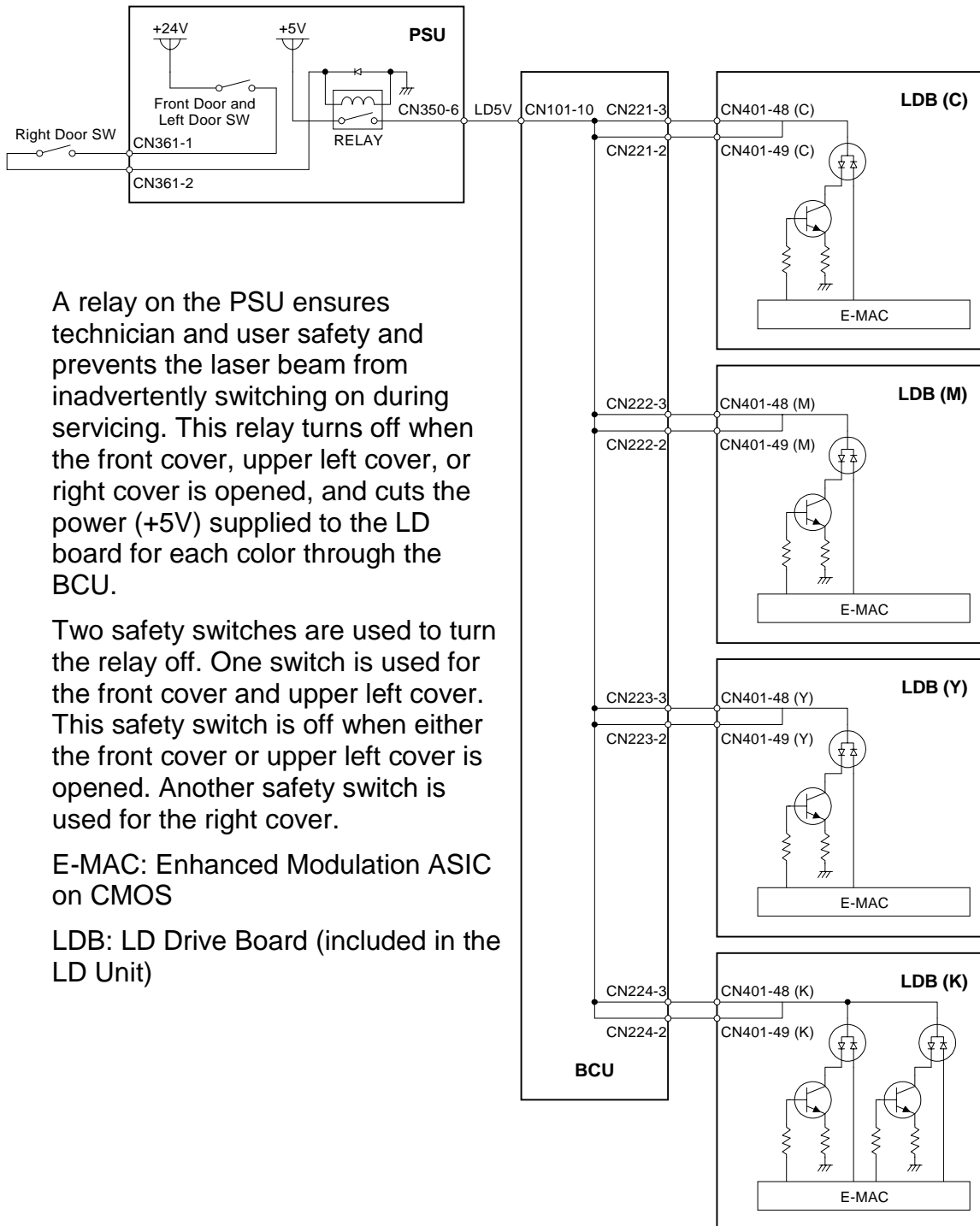

A relay on the PSU ensures technician and user safety and prevents the laser beam from inadvertently switching on during servicing. This relay turns off when the front cover, upper left cover, or right cover is opened, and cuts the power (+5V) supplied to the LD board for each color through the BCU.

Two safety switches are used to turn the relay off. One switch is used for the front cover and upper left cover. This safety switch is off when either the front cover or upper left cover is opened. Another safety switch is used for the right cover.

E-MAC: Enhanced Modulation ASIC on CMOS

LDB: LD Drive Board (included in the LD Unit)

Detailed Descriptions

6.3.6 AUTOMATIC LINE POSITION ADJUSTMENTS

Overview

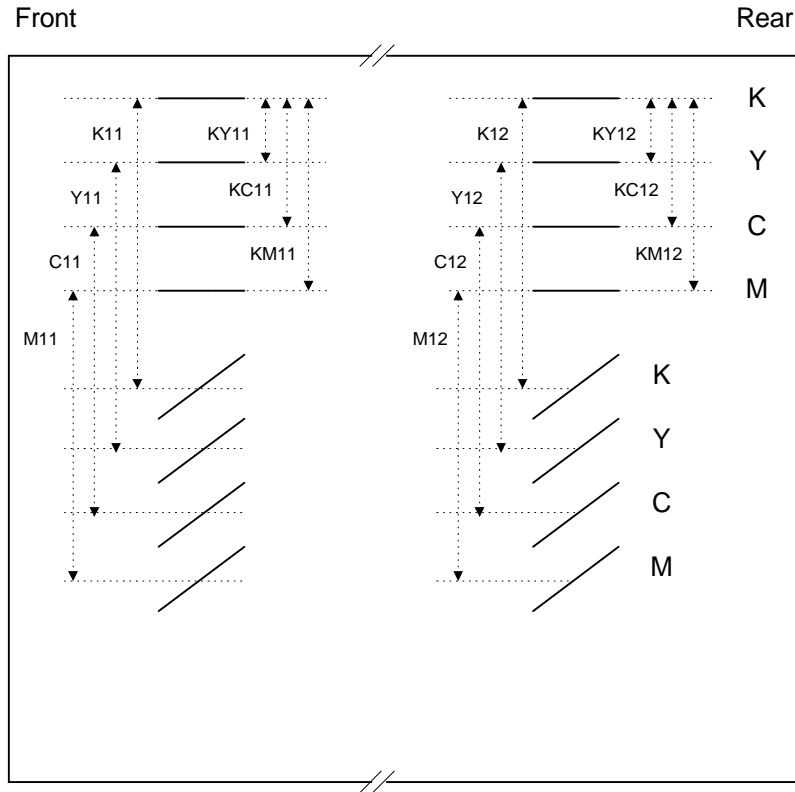

G060D205.VWMF

The machine automatically adjusts the following items by drawing lines (1 mm x 20 mm) on the transfer belt and measuring them using the two ID sensors (one at the front and one at the rear). The machine generates eight sets of these lines for each color on both sides (front and rear) of the transfer belt, and averages the results from measuring these sets.

1. Sub scan line position for YCM based on the line position for K (color registration)
2. Main scan line position for KYCM
3. Magnification ratio for KYCM
4. Skew for YCM based on the line position for K

The machine automatically executes the adjustment when it detects one of the following:

1. Depends on setting of SP5-993-1. The default is as follows:
 - If a process control self check is done (except after toner end recovery and developer initialization)
 - New PCU installed
 - If the temperature measured by the sensor on the laser optics housing unit differs by 5°C from the temperature at the previous adjustment when a color printing job starts, or during a printing job, or at any time during standby mode.
2. When the user or technician starts the adjustment with a user tool or SP5-993-2
NOTE: The skew adjustment is done only if a PCU is replaced with a new one or a forced image position adjustment is executed with SP5-993-2 or a UP mode.

After measuring the patterns, the machine cleans the transfer belt by applying a positive dc charge to the cleaning roller and turns the belt three full rotations.

If an error is detected three times consecutively, SC285 is generated.

Sub Scan Line Position for YCM

The machine measures the gaps between lines of each color on the pattern on the transfer belt. If the gaps are not correct, the machine moves the image for the required color up or down the sub scan axis. To do this, it changes the laser write timing for that color.

Main Scan Line Position for KYCM

If the machine detects that the image is out of position in the main scan direction, it changes the laser write start timing for each scan line.

Magnification Adjustment

If the machine detects that magnification adjustment is necessary, it changes the LD clock frequency for the required color.

Main Scan Skew Adjustment

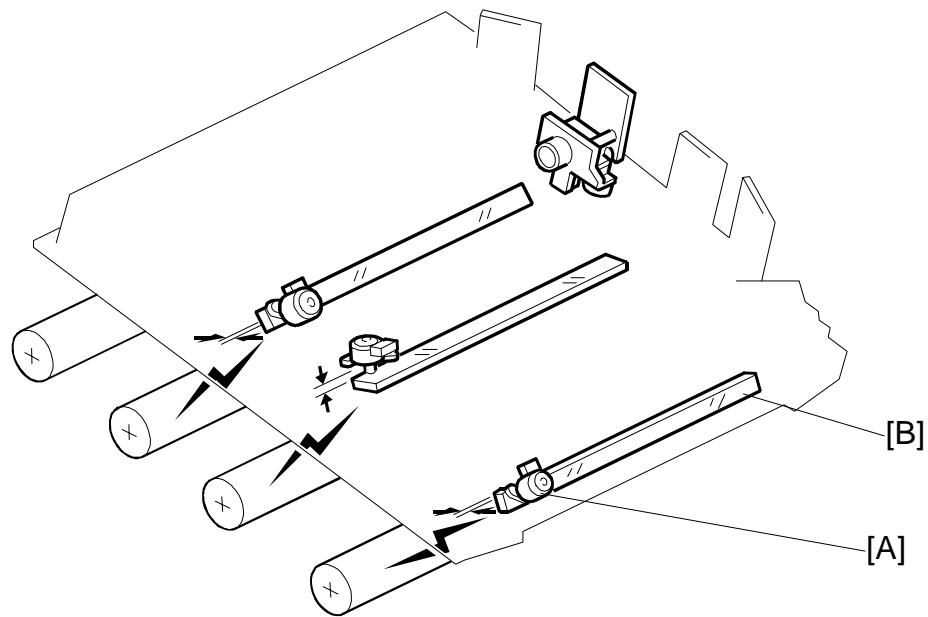

G060D254.WMF

The 3rd mirror positioning motors [A] for magenta, cyan, and yellow each adjust the angle of the 3rd mirror [B], based on the 3rd mirror position for black. This corrects main scan skew.

6.4 PHOTOCONDUCTOR UNIT

6.4.1 OVERVIEW

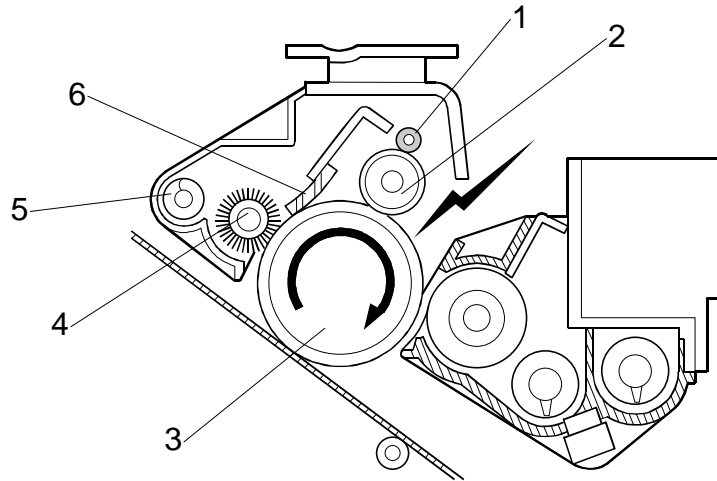

G060D301.WMF

- | | |
|--------------------------------|---------------------------------|
| 1. Cleaning brush roller | 4. Cleaning brush |
| 2. Charge roller (non-contact) | 5. Waste toner collection auger |
| 3. OPC drum | 6. Cleaning blade |

This machine has four independent PCUs, one for each color. Each PCU consists of an OPC drum, non-contact charge roller, cleaning brush, and cleaning blade. The diameter of the drum is 30 mm (circumference: about 94.25 mm).

The photoconductor gap between PCU and development roller is determined by the drum positioning plate and the rear shaft, and is not adjustable in the field.

The push switches in the drum positioning plate detect when a new PCU has been installed.

6.4.2 DRIVE

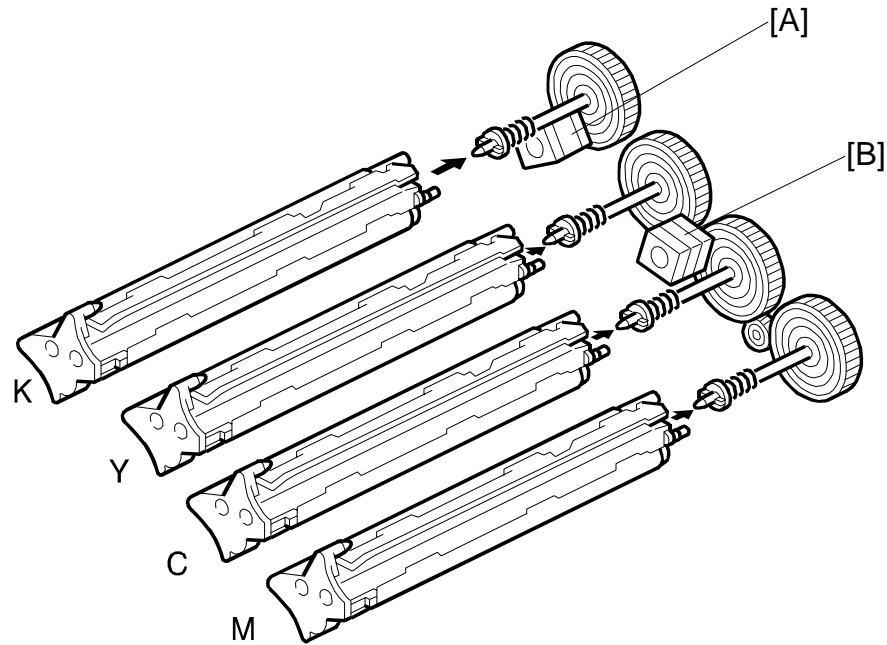

G060D302.WMF

The drum drive motor-K [A] drives the PCU for black. It also drives the transfer unit.
The drum drive motor-CMY [B] drives the PCUs for magenta, cyan, and yellow.
Using one motor to drive these three drums reduces CMY color misalignment.

6.4.3 DRUM CHARGE AND QUENCHING

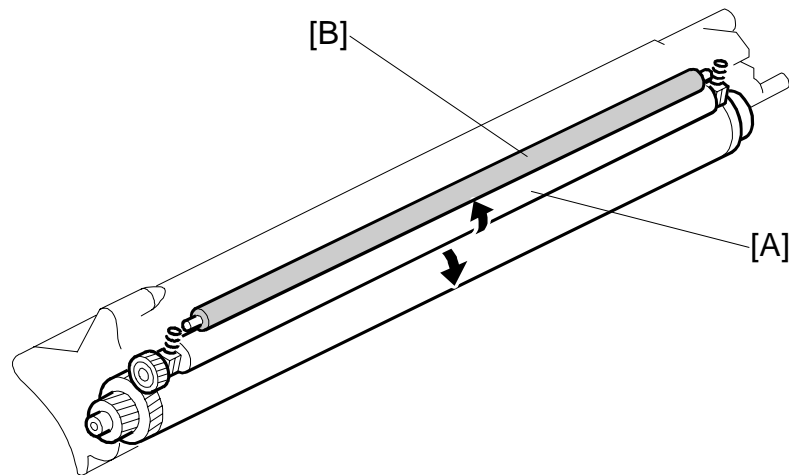

G060D303.WMF

This machine uses a non-contact charge roller [A] to reduce ozone. The non-contact charge roller gives the drum surface a negative charge. The high voltage supply board – C, B, which is located at the rear of the machine, applies a dc and ac voltage (at a constant current) to the roller. The ac voltage helps to ensure that the charge given to the drum is as uniform as possible.

The machine automatically controls the charge roller voltage, if automatic process control is enabled (i.e., if SP3-125-1 is set to 0). However, if process control is switched off, (i.e., if SP3-125-1 is set to 1), the dc voltage is the value stored in SP2-001-1 to -9 (do not adjust in the field unless advised to do so).

The diameter of the roller is 35 mm (circumference about 110 mm). The gap between drum and charge roller is about 50 μm .

The cleaning brush roller [B], which always contacts the charge roller, cleans the charge roller.

The charge roller can generate small amounts of nitrogen oxide gases (known as NO_x), which may be absorbed by the surface of the drum. This can cause unfocused copies. As a result, the film of NO_x is removed at power on, at the end of a job (if more than 200 prints), and when a toner cartridge has been replaced. SP3-920-1 to -4 determine when this procedure (known as 'refresh mode') is done. It can also be executed at any time if the prints are smeared (using SP3-920-5).

Quenching is done by illuminating the whole area of the drum with the laser at the end of every job.

6.4.4 DRUM CLEANING

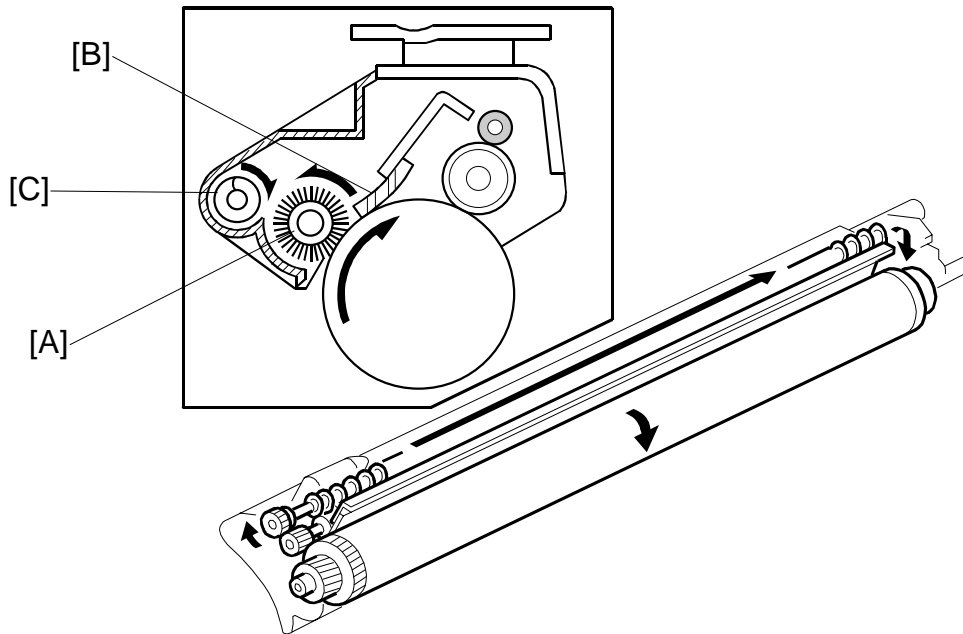

G060D305.WMF

The cleaning brush [A] spreads out the waste toner remaining on the drum. The cleaning blade [B] then scrapes it off. The toner collection auger [C] transports the toner towards the waste toner collection bottle.

6.4.5 WASTE TONER COLLECTION

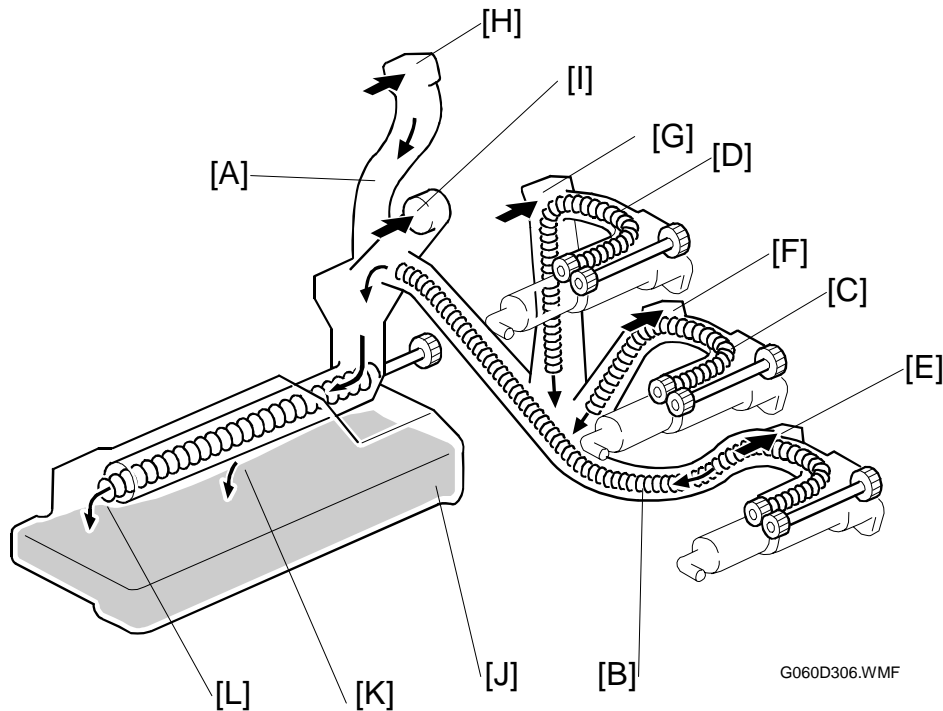

The waste toner from the collection augers in the four PCUs drops into the waste toner collection duct [A] at the rear of the PCU. The toner collection coils [B, C, D] in the duct transport this waste toner towards the waste toner bottle (M [E], C [F], Y [G], K [H]). The coils are driven by the development drive motor-CMY.

The toner [I] from the transfer unit drops directly into the waste toner bottle [J].

There are two holes in the waste toner collection duct. If the toner is unable to drop through the hole [K] at the centre of the bottle, it is transported to the end of the duct and drops into the bottle through the hole [L] at the end.

6.4.6 WASTE TONER BOTTLE FULL DETECTION

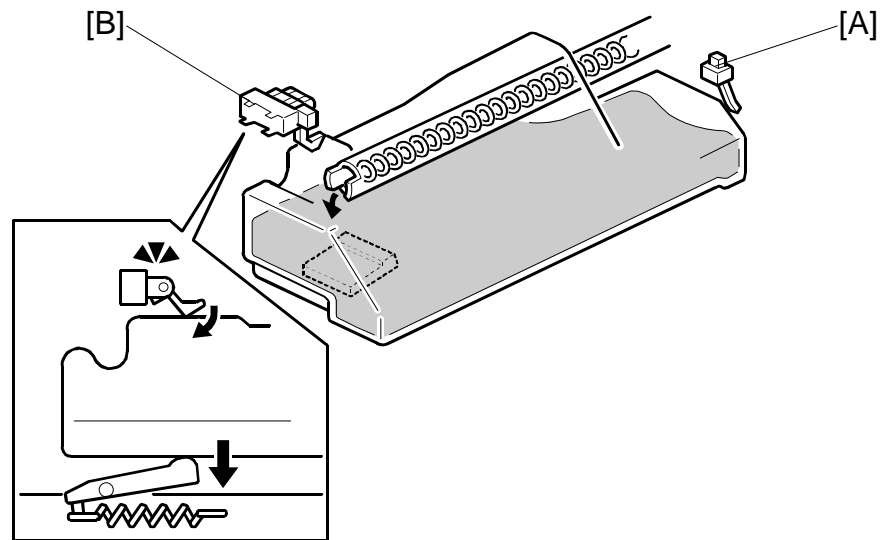

G060D315.WMF

The waste toner bottle set switch [A] detects when the bottle is placed in the machine.

The waste toner sensor [B] detects the weight of the bottle and informs when it is almost full.

When the bottle contains a certain amount of waste toner, the sensor is deactivated. The machine detects that the waste toner bottle is almost full and displays "Waste Toner is Almost Full".

After that, the machine can print 1,000 more sheets. After printing 1,000 sheets, it displays "Replace Waste Toner", and after the end of the job, the printer cannot be used until the bottle is replaced or emptied.

6.4.7 PCU DETECTION (DEVELOPMENT UNIT DETECTION)

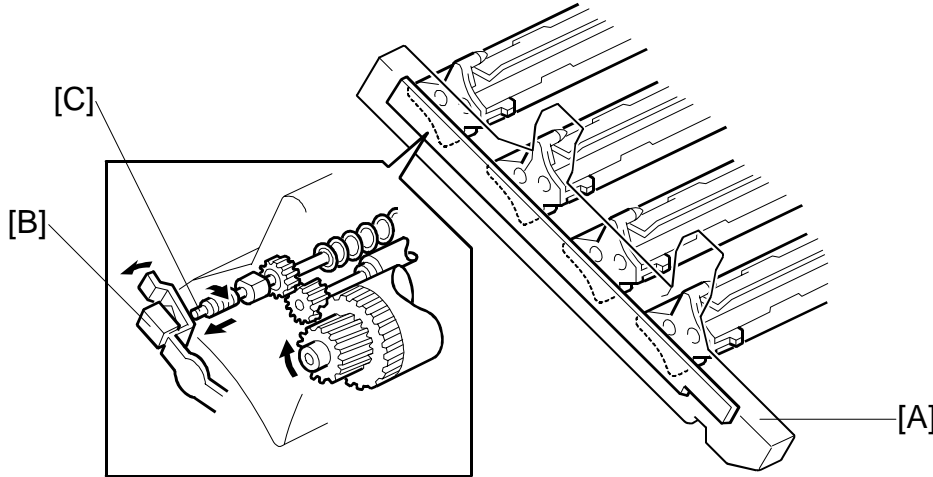

G060D307.WMF

The drum positioning plate [A] contains eight push switches [B]. These detect when a new PCU or a new development unit has just been installed. They also detect if the PCUs and development units are in the machine.

Each PCU and each development unit includes a pin [C], which activates the switch when the drum positioning plate is closed. On a new unit, this pin does not activate the switch. When the unit is driven for the first time, the pin comes out and activates the switch.

After the machine is turned on or the front cover is closed, the machine checks each switch (result 1 in the table). Then the machine drives the PCUs and development units for 5 seconds and checks each switch again (result 2 in the table). The condition detected by the machine depends on the combination of results, as shown below.

Detailed Descriptions

Result 1	Result 2	Detection	Action
OFF	OFF	The PCU or development unit is not placed in the machine, or the drum positioning plate is not secured by the two screws.	The machine displays an error message.
OFF	ON	A new PCU or development unit has just been installed.	The machine resets the counter for the PCU or development unit.
ON	ON	The current PCU or development unit is present.	The machine goes to standby mode.

NOTE: If some PCUs or development units are not installed, the machine displays error messages in the following order.

(M dev→M PCU→C dev→C PCU→Y dev→Y PCU→K dev→K PCU)

6.5 DEVELOPMENT

6.5.1 OVERVIEW

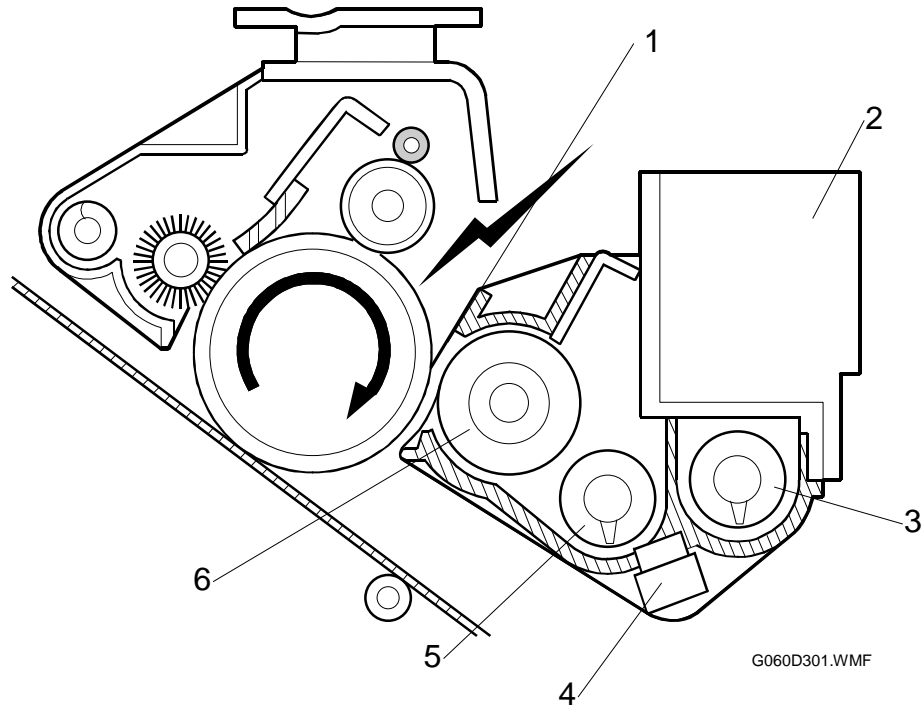

- | | |
|-------------------------|------------------------|
| 1. Doctor blade | 4. TD sensor |
| 2. Developer hopper | 5. Mixing auger (left) |
| 3. Mixing auger (right) | 6. Development roller |

This machine has four independent development units, one for each color. Each contains 280 g of developer when new. The developer in each unit is supplied to the development roller by the two mixing augers and attracted onto the surface of the roller.

The photoconductor gap between PCU and development roller is determined by the drum positioning plate and the rear shaft, and is not adjustable in the field.

The push switches in the drum positioning plate detect when a new development unit has been installed, and detect whether the development unit is in the machine.

The TD sensor and front ID sensor control toner density. Each development unit has a TD sensor.

The diameter of the development roller is 18 mm (circumference about 56.5 mm).

6.5.2 DRIVE

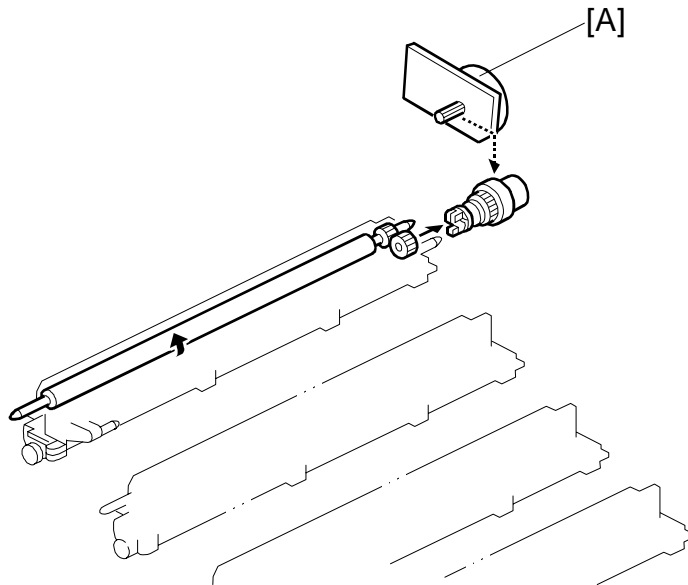

G060D311.WMF

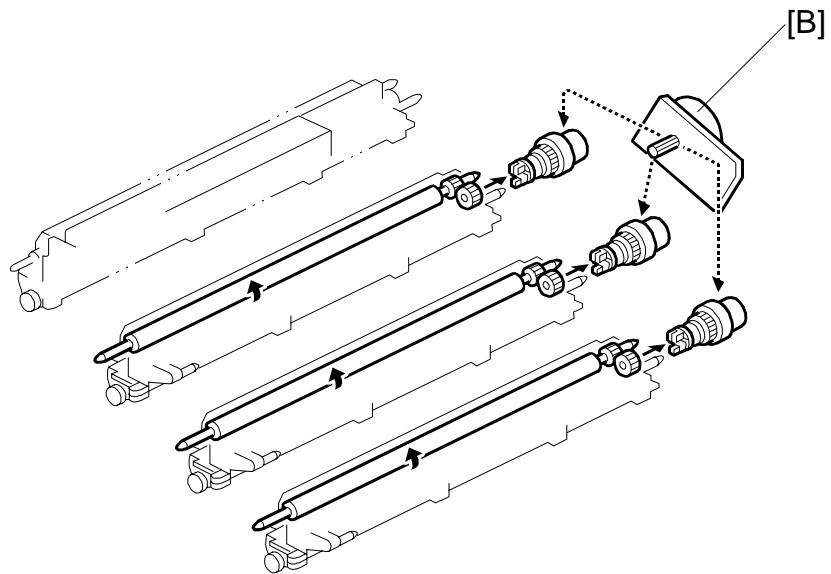

G060D310.WMF

The development drive motor-K [A] drives the development roller for black through gears and a clutch. This motor also drives the fusing unit and paper exit rollers. The gear trains are indicated in the diagram by dotted lines.

The development drive motor-CMY [B] drives the development unit for magenta, cyan, and yellow through gears and clutches. This motor also drives the registration roller and by-pass feed table.

Detailed
Descriptions

6.5.3 DEVELOPER AGITATION

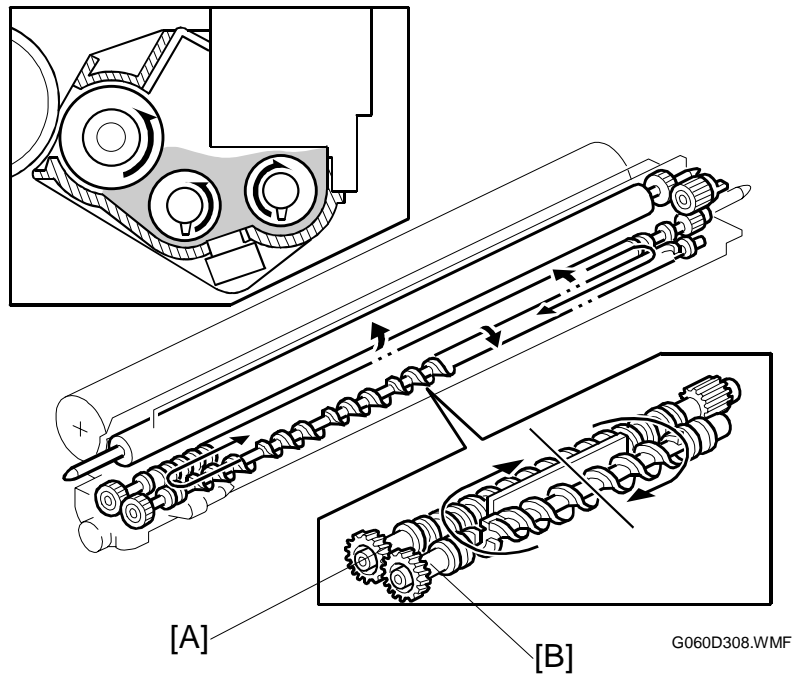

Two mixing augers [A and B] circulate the developer forward and backward to agitate the developer.

This happens during the process control self check, during toner supply, and during development.

6.5.4 DEVELOPMENT BIAS

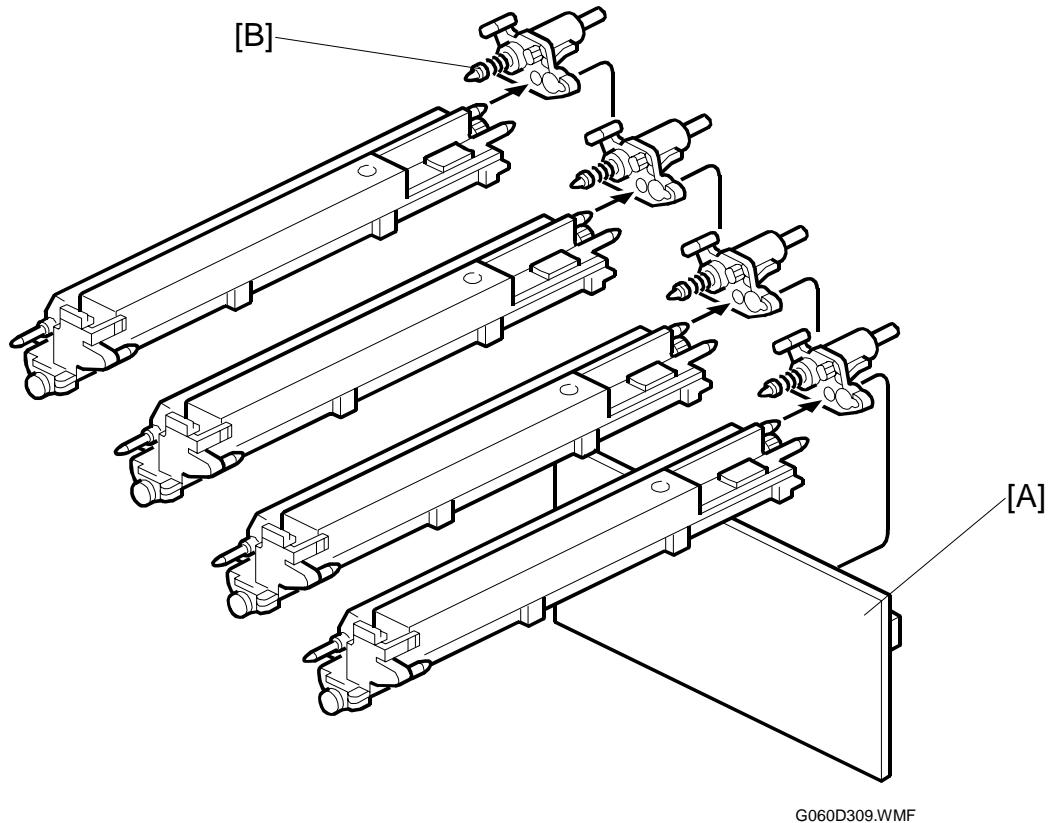

The high voltage supply board – C, B [A] supplies development bias to the development roller via a receptacle [B] at the rear of each development unit.

There are both ac and dc bias voltages. The ac bias improves toner transfer to the drum.

The machine automatically controls the dc bias, if automatic process control is enabled (i.e., if SP3-125-1 is set to 0). However, if process control is switched off, (i.e., if SP3-125-1 is set to 1), the dc bias is the value stored in SP2-201-1 to -9 (do not adjust in the field unless advised to do so).

The ac bias cannot be adjusted.

Detailed
Descriptions

6.5.5 DEVELOPMENT UNIT DETECTION

This is the same as PCU detection. See “Photoconductor Unit – PCU Detection’.

6.5.6 TONER SUPPLY MECHANISM

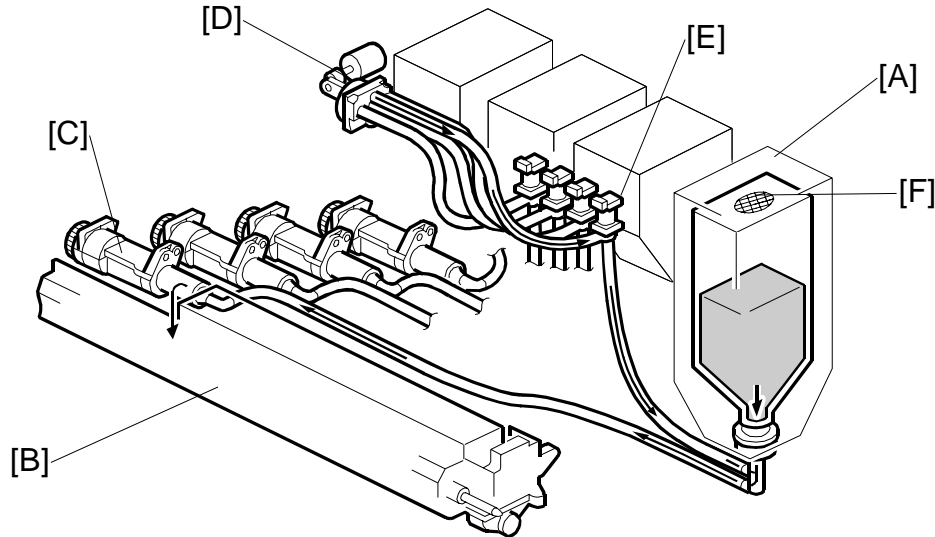

G060D313.WMF

Overview

An air transport system agitates the toner in the toner cartridges [A]. Toner is transported from the toner cartridge to the development unit [B] by the toner attraction pump [C] (each cartridge has a separate pump). This provides a more stable way to transport a fine powder than previous methods.

Toner Agitation

The air pump supplies air to the toner cartridge and air mixes with the toner and agitates all the toner in the cartridge. One air pump [D] and four valves [E] control the air flow.

The air pump turns on to supply air to the toner cartridge for one second at the following times:

- During normal operation, when the 'on' time for a toner supply clutch reaches a certain value
- When forced toner supply (SP2-207) is done
- When forced toner density adjustment (SP3-126-2) is done
- At toner end recovery
- Developer initialization

The filter [F] in the inner package of the toner cartridge ensures that the internal pressure does not become too high.

The toner mixed with air becomes a fluid, and passes part of the way along the transport tube towards the toner attraction pump. This pump draws the toner the rest of the way (see the next page).

Toner Transport

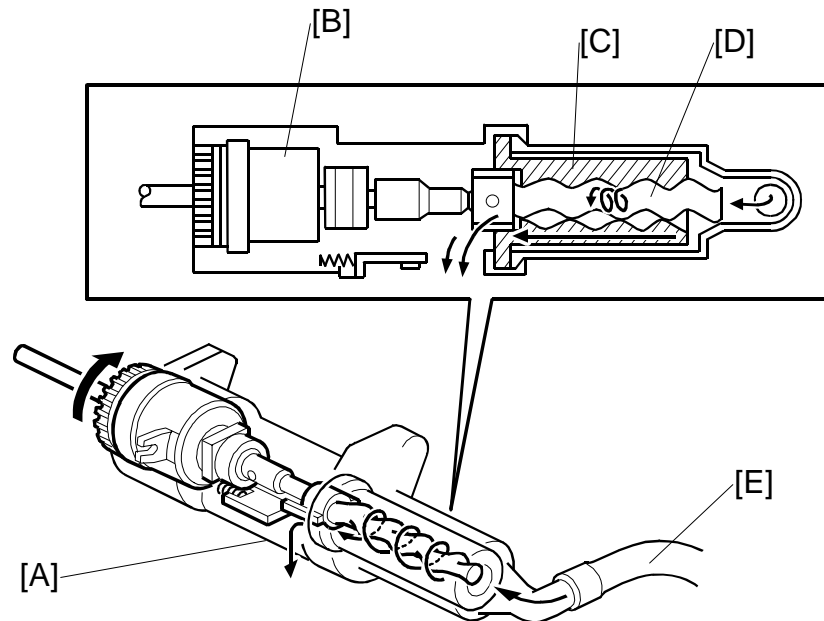

G060D314.WMF

Each toner attraction pump has the following mechanism.

The pump (toner attraction pump) [A], which consists of the toner supply clutch [B], rubber tube [C], and a rotor [D], attracts the toner in the toner transport tube [E] toward the development unit.

The toner supply clutch drives the rotor, which draws the toner in from the cartridge and passes it to the development unit. Each time the clutch comes on to supply toner, it turns on for 0.7 s and off for 1.3 s. The number of times that the clutch turns on depends on the amount of toner to be supplied, which depends on the results of toner supply control.

Motor drive comes from the development drive motors.

Shutter Mechanism

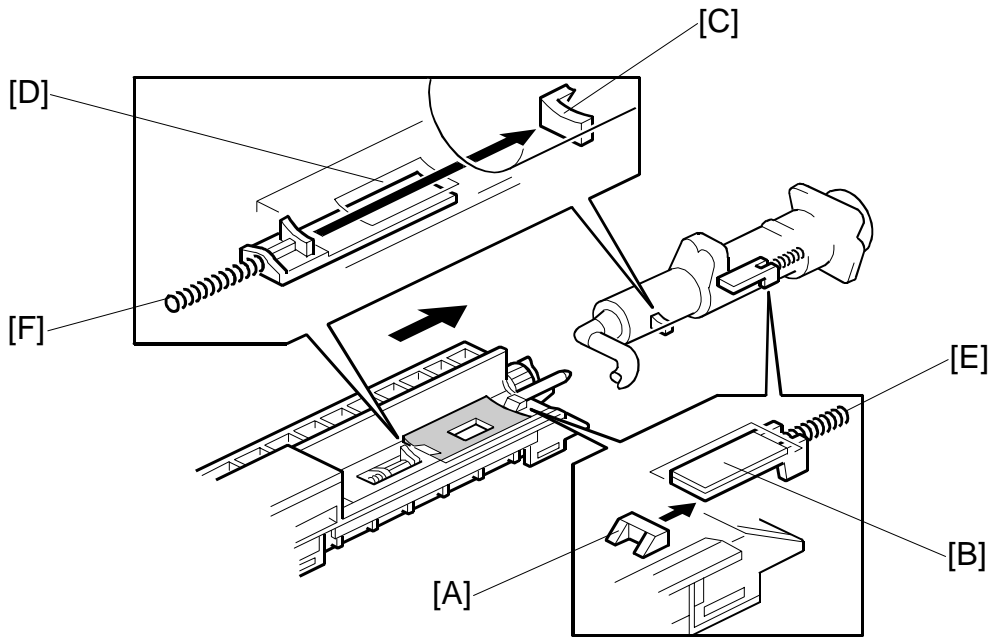

G060D312.WMF

The development unit and toner attraction pump each have a shutter mechanism. When the development unit is placed in the machine, the protrusion [A] on the development unit opens the shutter [B] in the pump, and the protrusion [C] on the pump opens the shutter [D] in the development unit. When both shutters are open, toner can enter the development unit from the toner attraction pump.

When the development is removed, the shutter spring [E and F] pulls and closes the shutter.

6.5.7 TONER CARTRIDGE DETECTION

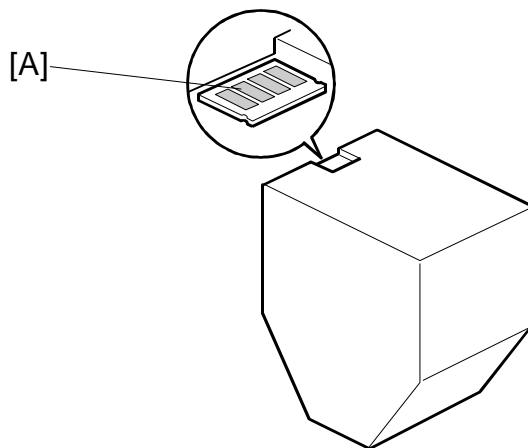

G060D316.WMF

A memory chip [A] on each toner cartridge stores the total 'on' time of the toner supply clutch. This is used to calculate the amount of toner remaining in the toner cartridge. The chip also detects whether the cartridge is installed (if the cartridge is not installed, the machine does not detect a signal from the memory chip).

6.6 PAPER FEED

6.6.1 OVERVIEW

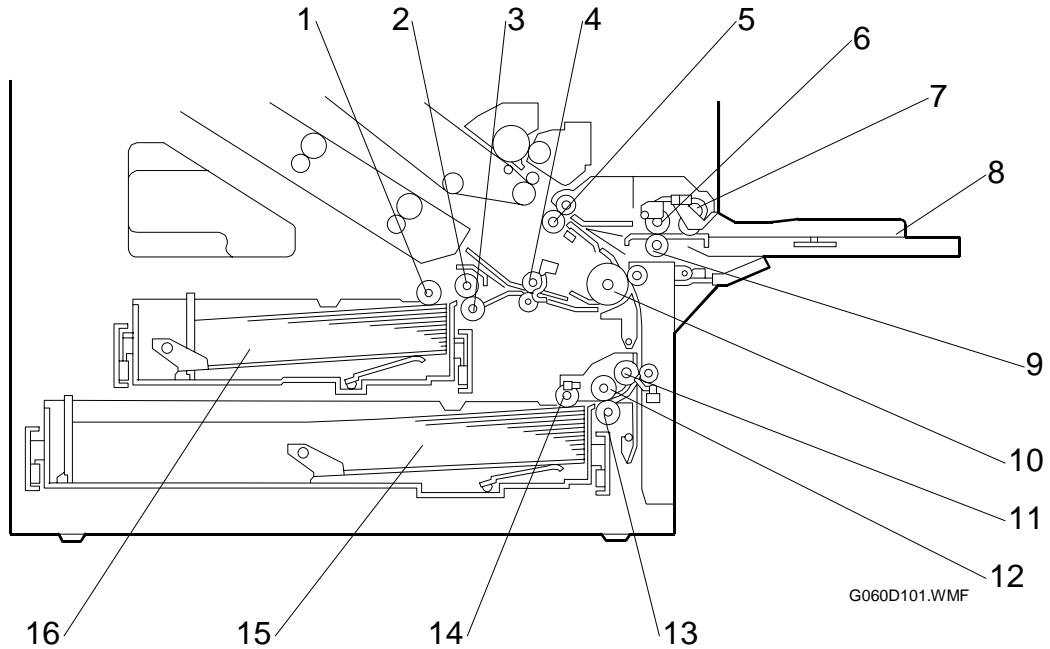

- | | |
|----------------------------------|-------------------------------------|
| 1. Pick-up roller - tray 1 | 9. Separation roller - By-pass feed |
| 2. Feed roller - tray 1 | 10. Transport roller |
| 3. Separation roller - tray 1 | 11. Vertical transport roller |
| 4. Relay roller | 12. Feed roller - tray 2 |
| 5. Registration roller | 13. Separation roller - tray 2 |
| 6. Feed roller - By-pass feed | 14. Pick-up roller - tray 2 |
| 7. Pick-up roller - By-pass feed | 15. Paper tray 2 |
| 8. By-pass feed table | 16. Paper tray 1 |

Detailed Descriptions

There are two paper trays (500 sheets each), and a by-pass feed table (100 sheets).

The paper feed mechanism uses an FRR system.

Tray 1 can only hold A4 or letter paper. Tray 2 can hold a range of sizes.

6.6.2 DRIVE – TRAYS 1 AND 2

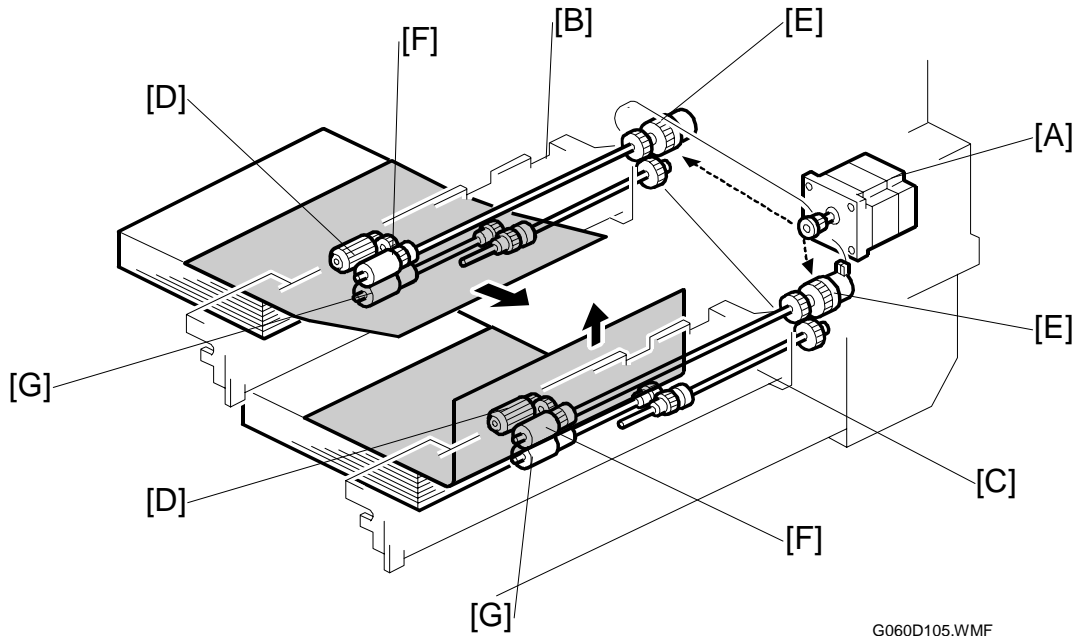

G060D105.WMF

The paper feed motor [A] drives the pick-up and feed mechanisms in both tray 1 [B] and 2 [C] using clutches and complex trains of gears (the locations of the gear trains are indicated by dotted lines in the above diagram).

When the paper tray is inside the machine, the pick-up roller [D] is always in contact with the top sheet of the paper stack. When the paper feed clutch [E] turns on, the pick-up, feed [F], and separation [G] rollers start rotating to feed the paper. The paper feed clutch stays on until shortly after the registration sensor activates.

6.6.3 PAPER LIFT – TRAYS 1 & 2

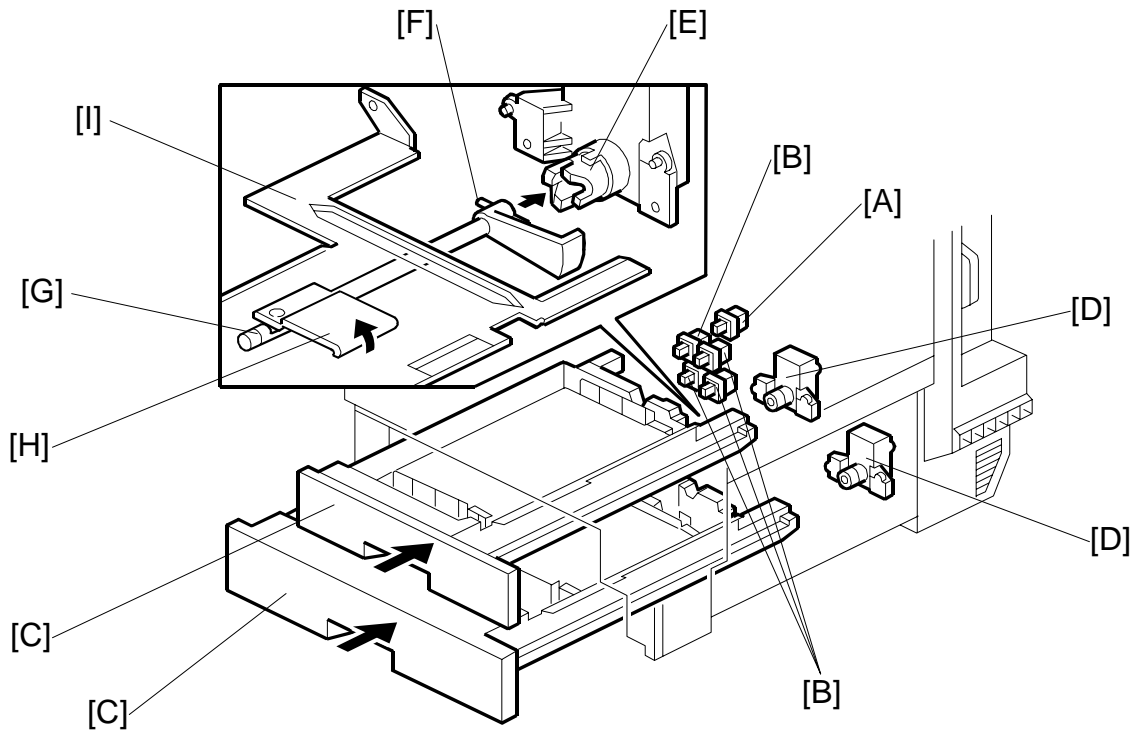

G060D102.WMF

The tray 1 set switch [A] and tray 2 paper size switches [B] detect when the paper trays [C] are placed in the machine. When the machine detects that a tray has been placed in the machine, the tray lift motor [D] rotates and the coupling gear [E] on the tray lift motor engages the pin [F] on the lift arm shaft [G]. Then the tray lift arm [H] lifts the tray bottom plate [I] until the paper lift sensor for the tray detects that the top of the stack is at the paper feed position.

Detailed
Descriptions

6.6.4 PAPER SIZE DETECTION – TRAYS 1 & 2

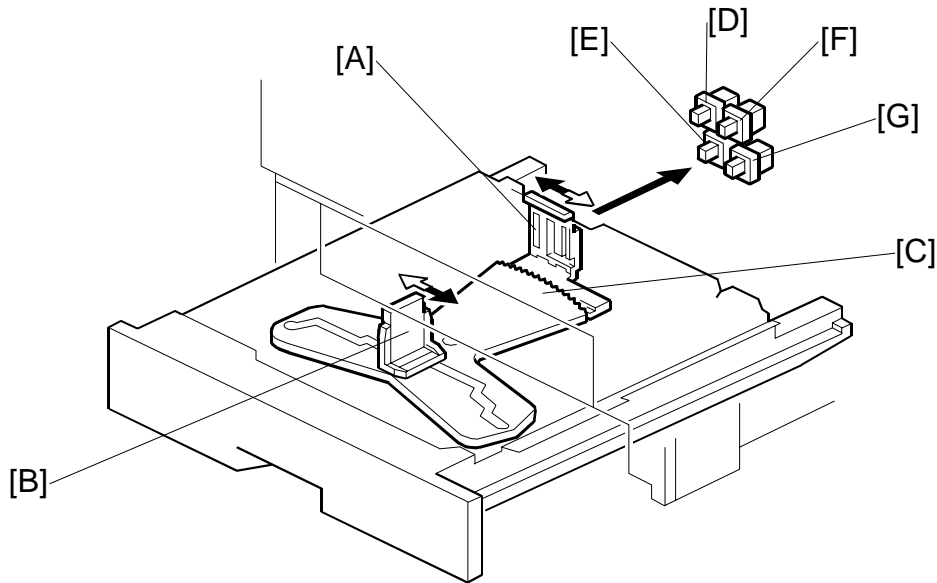

G060D104.WMF

For tray 1, there is no size switch. The paper size is fixed at either A4 or LT; this can be changed with SP1-902-1.

For tray 2, four paper size switches, working in combination, detect the paper size as shown in the table below. The actuators are on the side plate [A]. The side plate is moved by the end plate [B] through a cam [C].

Models		Switch Location			
North America	Europe/Asia	1 [D]	2 [E]	3 [F]	4 [G]
11" x 17" SEF	11" x 17" SEF	0	1	0	0
A3 SEF	A3 SEF	1	0	1	0
8 1/2" x 14" SEF *1	B4 SEF *1	1	1	0	1
8 1/2" x 11" SEF *2	A4 SEF *2	0	1	1	0
11" x 8 1/2" LEF *3	11" x 8 1/2" LEF *3	1	0	1	1
A4 LEF	A4 LEF	0	1	0	1
B5 LEF	B5 LEF	0	0	1	0
A5 LEF	A5 LEF	0	0	0	1

1: Pushed

Notes:

*1: The machine detects either 8 1/2" x 14" SEF or B4 SEF, depending on the setting of SP 1-902-2

*2: The machine detects either 8 1/2" x 11" SEF or A4 SEF, depending on the setting of SP 1-902-3

*3: The machine detects either 11" x 8 1/2" LEF or B5 SEF, depending on the setting of SP 1-902-4

The machine disables paper feed from a tray if the paper size cannot be detected (if the paper size actuator is broken or no tray is installed).

6.6.5 PAPER HEIGHT DETECTION – TRAYS 1 & 2

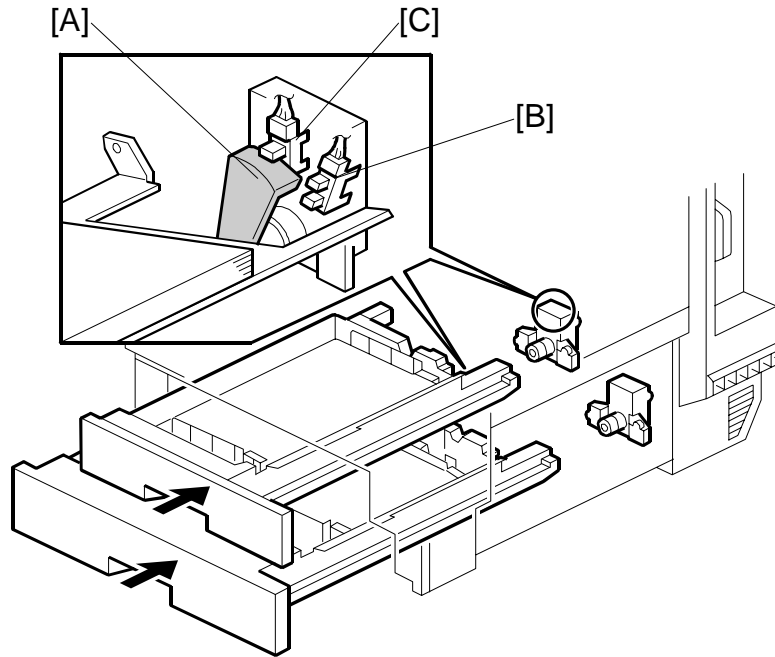

G060D103.WMF

Two paper height sensors, working in combination, detect the amount of paper in the tray.

When the amount of paper decreases, the bottom plate pressure lever moves up and the actuator [A] (on the pressure lever drive shaft) rotates.

Remaining paper	Paper height sensor 2 [B]	Paper height sensor 1 [C]
Full	OFF	OFF
Nearly full	ON	OFF
Near end	ON	ON
Almost empty	OFF	ON

OFF: No actuator

Detailed Descriptions

6.6.6 PAPER END DETECTION – TRAYS 1 & 2

If there is some paper in the paper tray, the paper stack raises the paper end feeler and the paper end sensor deactivates.

When the paper tray runs out of paper, the paper end feeler drops into the cutout in the tray bottom plate, and this activates the paper end sensor.

6.6.7 REGISTRATION

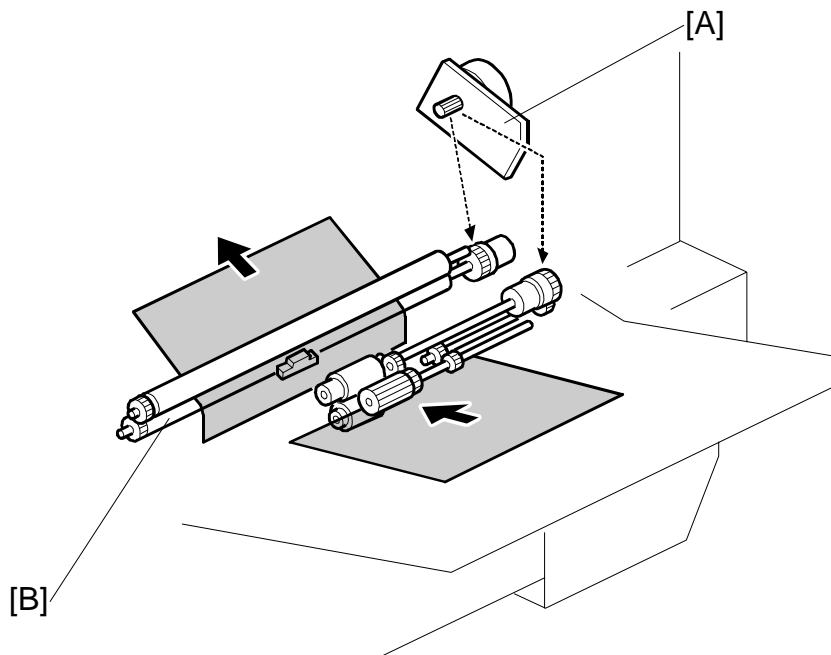

G060D106.WMF

The development drive motor - CMY [A] drives the registration roller [B] using a clutch and a complex train of gears (the location of the gear train is indicated by dotted lines in the above diagram).

The machine makes a paper buckle at the registration roller to correct paper skew. The paper buckle can be adjusted with SP1-003-1 to - 8.

6.6.8 PAPER FEED LINE SPEED

This machine has three process line speeds (for feed from registration roller to fusing unit) depending on the selected resolution

Mode	Resolution (dpi)	Line speed (mm/s)	Print speed (ppm)
B/W	600 x 600	185	38
	1,200 x 600		
	1,200 x 1,200	125	28
Color	600 x 600	125	28
	1,200 x 600		
	1,200 x 1,200	62.5	14
OHP/Thick	600 x 600	62.5	10
	1,200 x 600		
	1,200 x 1,200		

During a monochrome print job, the machine changes the line speed if there is a page with color in the middle of the job. However, it will not change the line speed if there is a monochrome page in the middle of a color print job.

	Line speed (mm/s)
Paper feed from tray to registration roller	230
Fusing, paper exit to standard tray, and mailbox	A bit slower than "Process line speed"
Duplex invert and feed	370
Finisher	450

6.6.9 BY-PASS TRAY

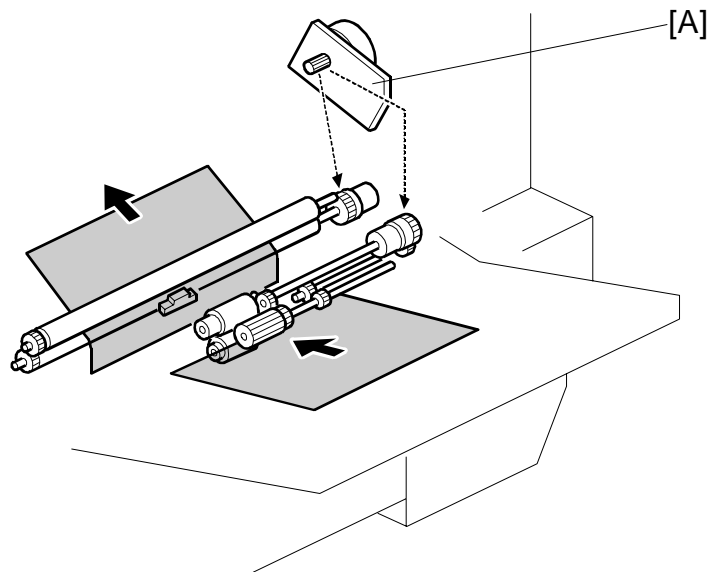

G060D106.WMF

The development drive motor - CMY [A] drives the by-pass tray using a clutch and a complex train of gears (the location of the gear train is indicated by dotted lines in the above diagram).

To feed paper, the by-pass pick-up solenoid (not shown in the diagram) moves the pick-up roller into contact with the top of the stack.

Paper size and end detection are done in the usual manner.

6.7 IMAGE TRANSFER AND PAPER SEPARATION

6.7.1 OVERVIEW

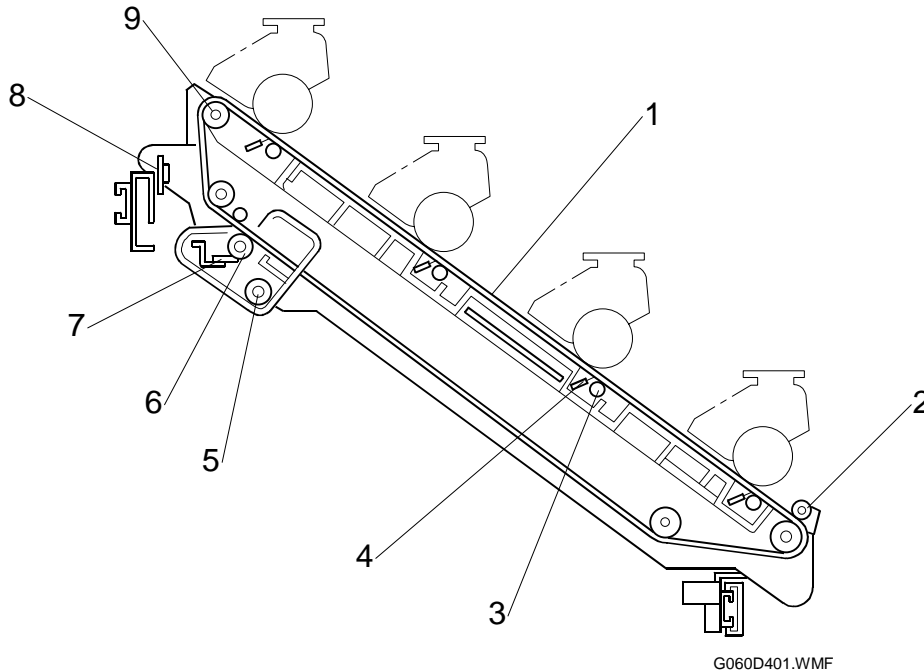

G060D401.WMF

- | | |
|----------------------------|-------------------------------|
| 1. Transfer belt | 6. Cleaning roller |
| 2. Paper attraction roller | 7. Cleaning blade |
| 3. Back-up roller | 8. ID sensor |
| 4. Transfer charge brush | 9. Transfer belt drive roller |
| 5. Toner collection auger | |

Paper is fed to the transfer belt before image transfer begins. The paper attraction roller charges the paper to ensure that the paper is attracted to the belt.

The magenta, cyan, yellow, and black color images transfer to the paper while the transfer belt feeds the paper past the drums towards the fusing unit. A positive charge is applied to the paper under the transfer belt, opposite each drum, to transfer the toner from the drums onto the paper. The back-up roller ensures that the contact area between the drum and belt is sufficient.

The cleaning unit in the transfer unit cleans the belt surface by applying a charge to a cleaning roller. The waste toner collected from the belt is transported to the waste toner bottle.

There are two ID sensors. Only the front one detects the image density of the patterns generated on the transfer belt for process control. The other function of the ID sensors is for automatic line position adjustment. Both sensors are used for this.

6.7.2 TRANSFER BELT DRIVE

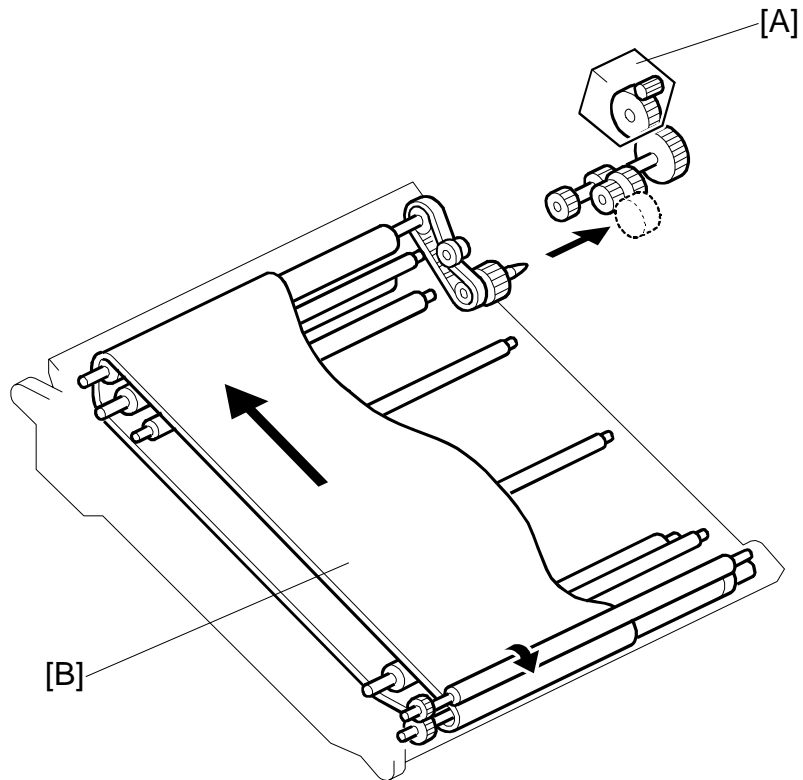

G060D402.WMF

The drum drive motor-K [A] drives the transfer belt [B] and the cleaning unit via some gears. The speed of transfer belt drive depends on the process line speed.

6.7.3 TRANSFER AND CLEANING CURRENT

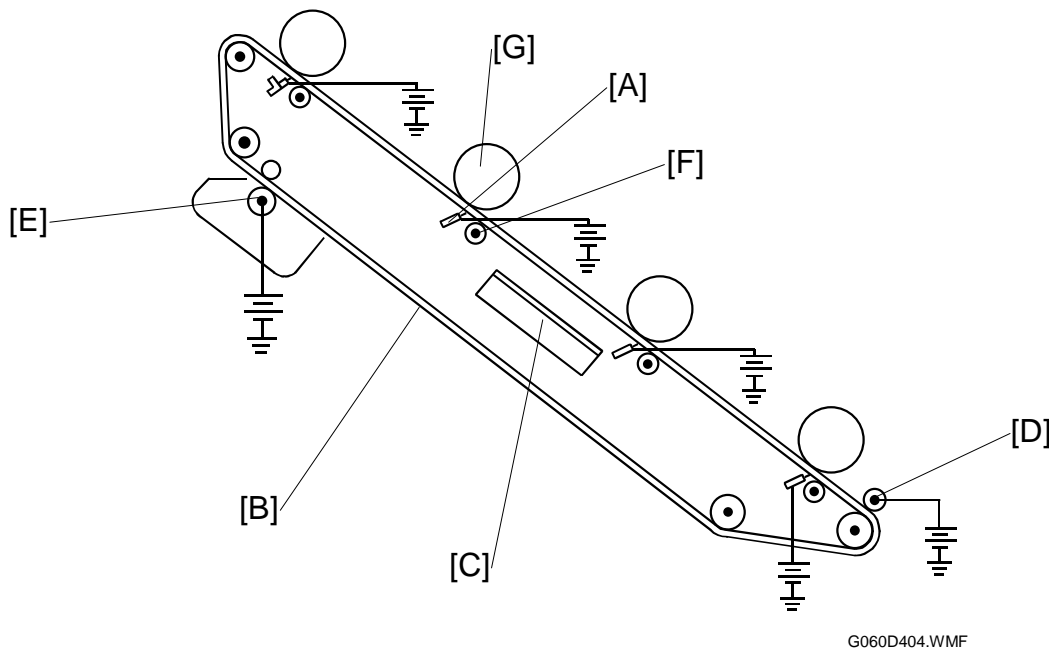

G060D404.WMF

The transfer charge brush [A] applies a current to transfer the toner to the paper [B].

The high voltage supply board – T, PA, CL [C] applies a current to the brush, paper attraction roller [D], and cleaning roller [E].

These currents, except for cleaning, are automatically corrected for paper size, temperature (measured by the thermistor on the right side of the laser optics housing unit), and humidity (measured by the humidity sensor).

Available adjustments are summarized below.

- The transfer brush current for each printing mode (color or B/W, resolution, paper type) can be adjusted with SP2-301-1 to -56. The by-pass tray settings are used when the duplex unit has not been installed and the user is making duplex prints manually from the by-pass tray. There is a correction for narrow-width paper with SP2-309-1 to -4.
- The current for paper attraction can be adjusted with SP2-801-1 to -9. There is a correction for narrow-width paper with SP2-801-10 to -13.
- The current for cleaning cannot be adjusted.

The back-up rollers [F] before the transfer charge brushes for each color make a wider contact area between the drum [G] and the belt. The other rollers are grounded to neutralize the belt surface.

6.7.4 TRANSFER BELT CLEANING

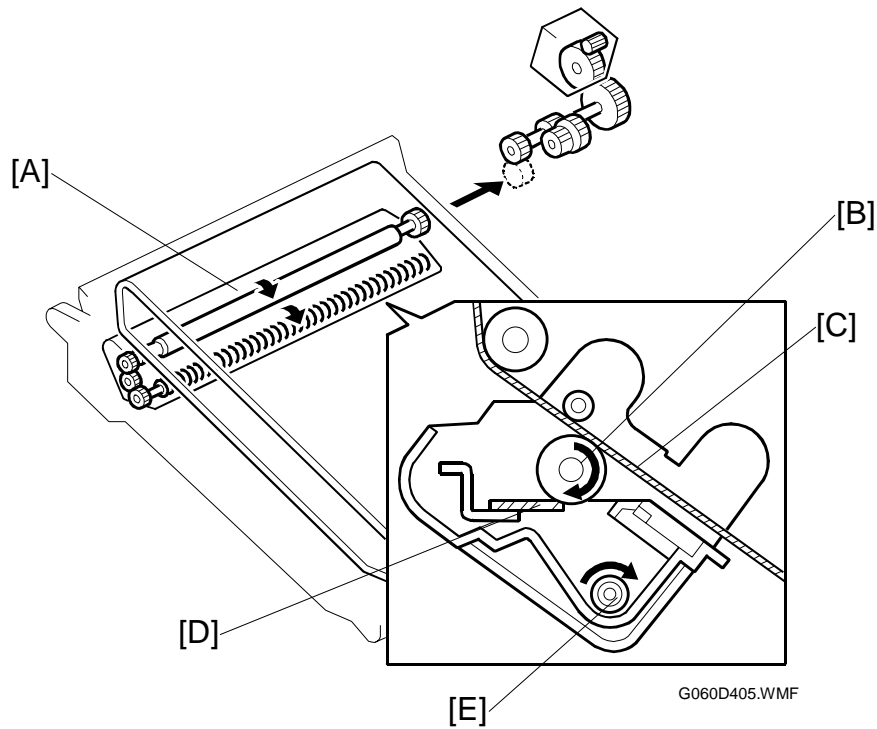

The transfer belt cleaning unit [A] removes toner on the belt after printing, the ID sensor patterns for process control, and the ID sensor patterns for automatic line position adjustment.

The cleaning roller [B] always contacts the transfer belt [C], and attracts waste toner from the belt (the cleaning roller is electrically charged). The blade [D] in the cleaning unit scrapes the toner off the cleaning roller. The toner collection auger [E] transports the toner towards the waste toner collection bottle.

6.7.5 TRANSFER BELT CONTACT

Mechanism

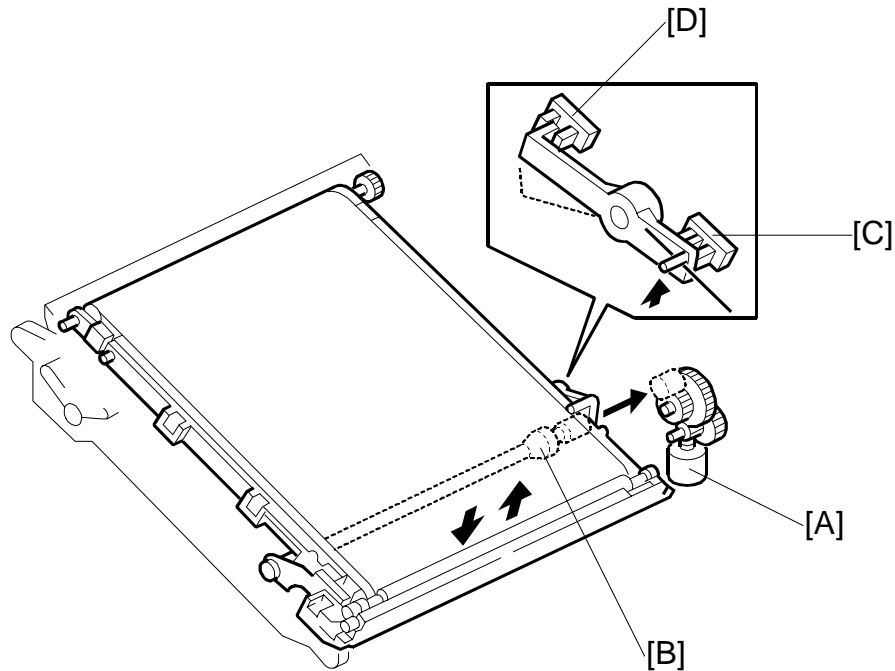

G060D403.WMF

The transfer belt contact and release mechanism improves the lifetime of the transfer belt and drums.

The drum for black always contacts the belt, but the transfer belt moves away from the other drums during monochrome printing.

In standby mode, the transfer belt contacts only the black drum. When the machine prints a color page, the machine waits until the previous page has gone through the transfer unit. Then the transfer belt contact motor [A] turns on and a cam [B] moves the lower end of the transfer belt upwards so that it contacts the other three drums.

The transfer belt home position [C] and contact [D] sensors detect the transfer belt positions, as follows:

	B/W printing (default position)	Moving to color printing position →		Color printing	Moving back to the default position →		Default position
HP sensor [C]	On	On	Off	Off	Off	On	On
Contact sensor [D]	Off	On	On	Off	On	On	Off

Off: Actuator not inside sensor

The machine does not release the transfer belt from the color drums during the job, even if a monochrome page comes again. This is because the total printing speed reduces if the transfer belt changes position often.

To pull out the transfer belt, the user moves the release lever and the belt moves down and away from all four drums. Then the unit can be pulled out.

Detailed Descriptions

ACS (Auto Color Sensing) Mode

ACS: On

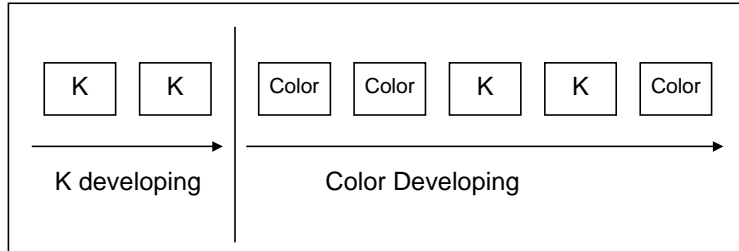

ACS: Off

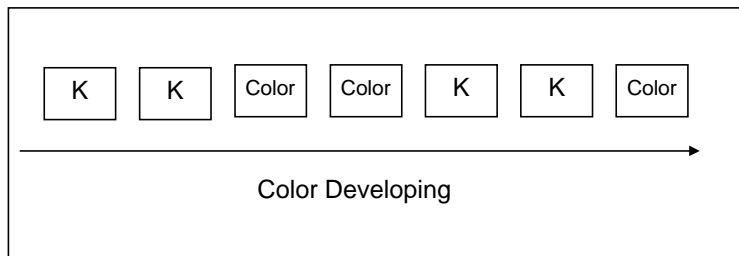

G060D406.WMF

The machine can print in color or monochrome mode (selected with the printer driver). In color mode, ACS can be switched on or off with a user tool (default: on).

If ACS is on, the transfer belt stays in the default position (against the K drum only) until a page with color data on it appears. The transfer belt then moves against all four drums and stays there until the end of the job, even if some K only pages appear.

If ACS is off, all data is printed with the transfer belt positioned against all four drums. The belt does not move even if a K only page appears, even if it is at the start of the job.

6.8 FUSING

6.8.1 OVERVIEW

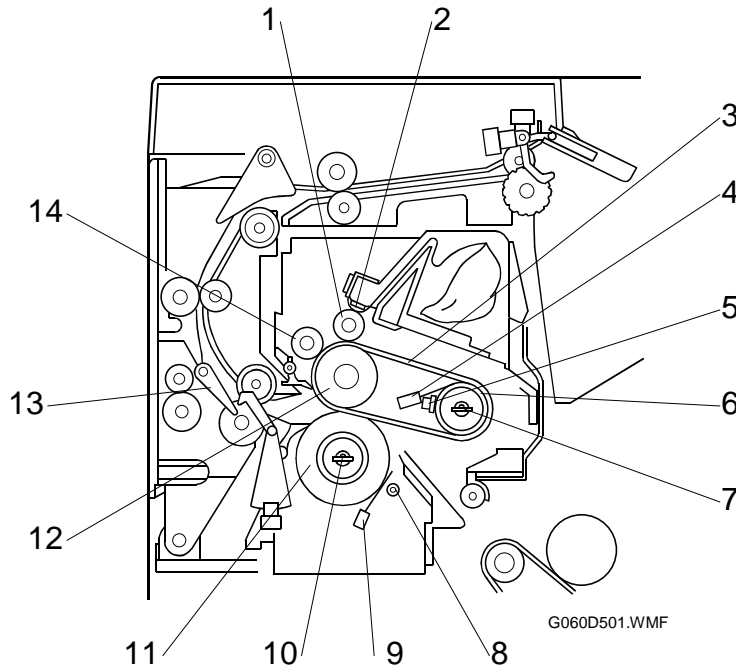

- | | |
|-------------------------------|---------------------------------|
| 1. Oil supply roller | 8. Pressure roller thermofuse |
| 2. Oil supply pad | 9. Pressure roller thermistor |
| 3. Fusing belt | 10. Pressure roller fusing lamp |
| 4. Heating roller thermistor | 11. Pressure roller |
| 5. Heating roller thermostat | 12. Hot roller |
| 6. Heating roller | 13. Junction gate |
| 7. Heating roller fusing lamp | 14. Cleaning roller |

- A belt fusing system is used. This has a faster warm-up time than a conventional hot and pressure roller system.
- The heating roller is made of aluminum to increase the temperature of the fusing belt quickly.
- The hot roller is made of sponge, which flattens slightly, also increasing the fusing nip. This roller does not contain a fusing lamp.
- The heating and pressure rollers each have a fusing lamp.
 - 770W for the heating roller, 350W for the pressure roller
- The heating roller thermistor and pressure roller thermistor control the temperature of these lamps.
- Temperature is normally controlled by turning the fusing lamps on and off. To change between on/off control and phase control: SP1-104-1

6.8.2 FUSING UNIT DRIVE

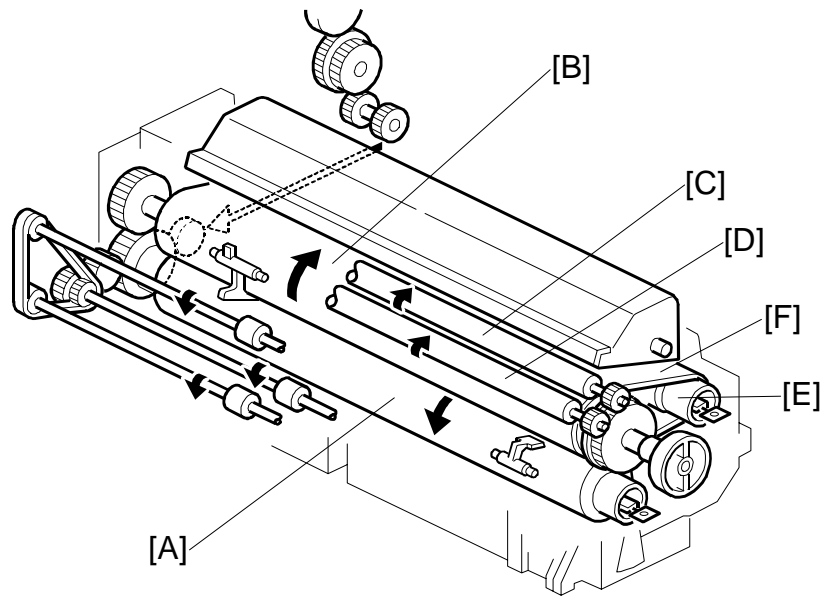

G060D503.WMF

- The development drive motor-K drives the pressure roller [A], hot roller [B], oil supply roller [C], and belt cleaning roller [D] through a gear train.
- The heating roller [E] is driven by the pressure with the fusing belt [F].

6.8.3 FUSING TEMPERATURE CONTROL

Fusing Temperatures

When the main switch turns on, the CPU turns on the fusing lamp. The lamp stays on until the thermistor detects the standby temperature. Then the CPU raises the temperature to the printing temperature.

The fusing temperature for each mode is as follows.

Mode	Resolution (dpi)	Temperature of Heating Roller	Temperature of Pressure Roller	Note
Energy saver level 1		100°C	130°C	
Standby mode		165°C	135°C	If SP1-104-025 is set to 4
Color	1200 x 1200	140°C	120°C	
	1200 x 600 600 x 600	170°C	150°C	
Black and white	1200 x 1200	165°C	145°C	
	1200 x 600 600 x 600	175°C	155°C	
OHP	All	170°C	150°C	
Thick	All	175°C	155°C	
Color (duplex back side)	1200 x 1200	135°C	115°C	
	1200 x 600 600 x 600	160°C	140°C	
Black and white (duplex back side)	1200 x 1200	155°C	135°C	
	1200 x 600 600 x 600	165°C	145°C	

The heating and pressure roller temperatures for fusing are stored in SP1-105-3 to -28.

When the machine is switched on, the fusing lamp temperatures increase to the those specified by SP1-104-25.

The print ready temperature is slightly less than the fusing temperature. The difference is specified by SP1-105-1 and -2.

Temperature Corrections

To prevent excessive glossiness caused by fusing temperature overshoot, there are the following SP modes:

- 1-913: Fusing temperature is reduced after this number of pages during the job.
- 1-914: This shows how much the temperature is reduced

If a job using OHP or thick paper starts while the fusing unit is still warm, the fusing temperature could be higher than the target for this type of paper, causing marks on the output. To prevent this problem, we have the following SP modes:

- 1-996-4, 5: These SPs specify a limit, above which printing will not start.

Overheat Protection

- If the heating or pressure roller temperature becomes greater than 200°C, the CPU cuts off the power to the fusing lamp. SC543 for the heating roller or SC553 for the pressure roller is generated.
- If thermistor overheat protection fails, there is a thermostat for the heating roller and a thermofuse for the pressure roller in series with the common ground line of the fusing lamp.
 - If the thermostat temperature becomes greater than 210°C, the thermostat opens, removing power from the fusing lamp.
 - If the thermofuse temperature becomes greater than 169°C, the thermofuse opens, removing power from the fusing lamp.
 - At this time, the machine stops operation.

6.8.4 OIL SUPPLY AND CLEANING

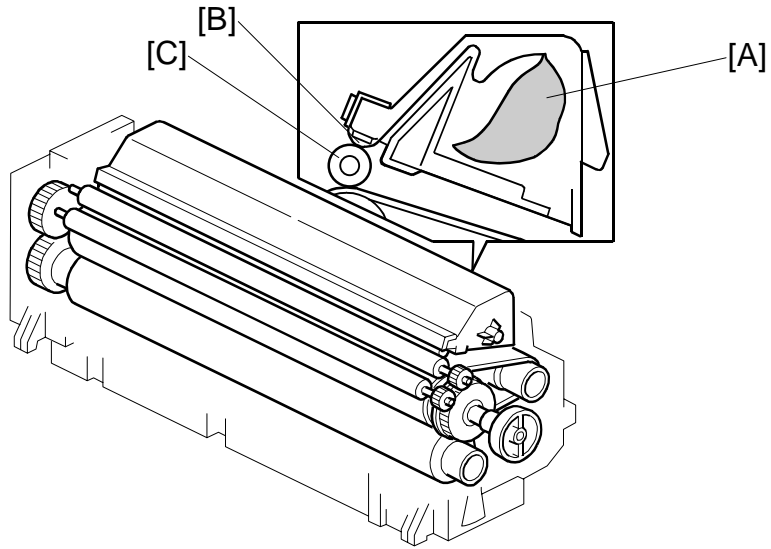

G060D505.WMF

- The oil supply mechanism makes it easier for paper to separate from the fusing belt and roller after fusing.
- The oil [A] from the oil supply pad [B] is supplied to the oil supply roller [C]. The oil supply roller rotates and supplies a bit of oil to the fusing belt.

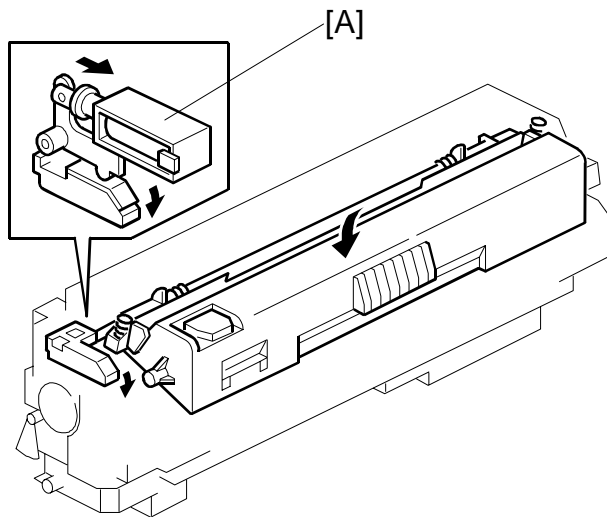

G060D508.WMF



- The oil supply solenoid [A] moves the oil supply roller into contact with the fusing belt. It stays in contact at all times during fusing. At other times, it moves away to reduce oil consumption.

Detailed Descriptions

6.8.5 NEW FUSING OIL SUPPLY UNIT DETECTION

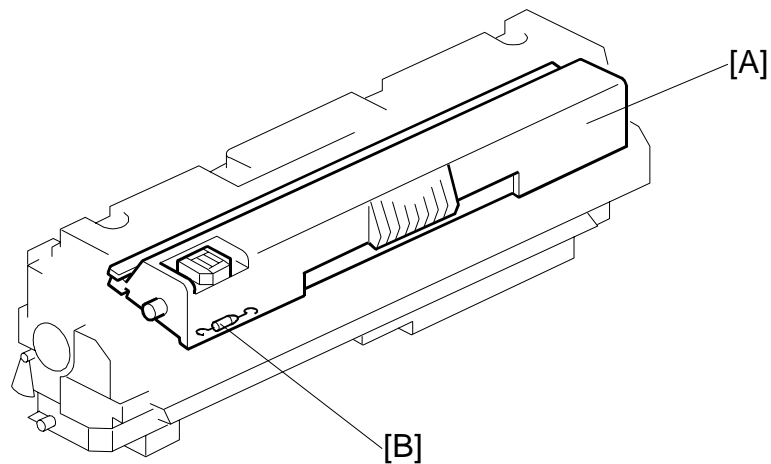

G060D507.WMF

The fusing oil supply unit [A] contains a fuse [B] in a circuit between the fusing unit and the BCU board. The fuse opens shortly after a new unit has been installed in the machine, and the power switched on. When the power is turned on or the left cover is closed, the BCU checks whether a new fusing oil supply unit is installed by checking the fuse condition. If the fusing oil supply unit has been replaced, the machine detects the new unit and automatically resets the counter for the unit.

Oil near-end is detected by counting the number of prints made. The machine indicates oil near-end 2,500 sheets before the life of the oil supply unit runs out. This timing can be changed with SP7-905-9.

6.8.6 NEW FUSING UNIT DETECTION

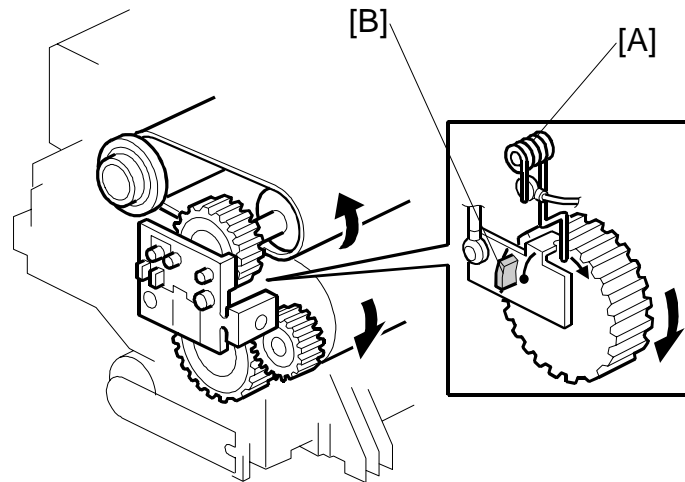

G060D506.WMF

The new fusing unit contains a spring [A] as part of a circuit connected to the BCU. After a new unit has been installed in the machine and the fusing pressure roller is driven for the first time, a pin [B] on the fusing pressure roller picks off the spring and the looped wire circuit opens.

When the power is turned on or the left cover is closed, the BCU checks whether the looped wire circuit is open or closed. If the fusing unit has just been replaced, the circuit is still closed, and the machine detects the new unit. It then automatically resets the counter for the unit.

The fusing unit's life is detected by counting the number of prints made. The machine indicates near-end 2,500 sheets before the life of the unit runs out. This timing can be changed with SP7-905-7.

6.8.7 ENERGY SAVER MODE

When the machine is not being used, the energy saver feature reduces power consumption by switching off the fusing lamp. This machine has two energy saver modes.

Level 1 Energy Saver Mode



Level 1 energy saver mode starts 20 seconds after the machine has completed a print. In this mode, the fusing lamps are intermittently turned on and off to keep the heating roller at 100°C and pressure roller at 130°C.

The machine leaves this mode when one of the following happens.

- Print command received from the PC
- Any cover opened and closed
- Any operation panel keys pressed

Level 2 Energy Saver Mode

Level 2 energy saver mode starts after the machine has been idle for a certain time. This time is specified by a user tool. During level 2 energy saver mode, both lamps switch off.

- Off (energy saver mode never activates)
- 5 minutes
- 15 minutes
- 30 minutes
- 45 minutes
- 60 minutes (default)

When the machine is in this mode, the machine turns off +24V, +12V, and +5V lines. However, only +5VE lines, for the controller and GAPCI (voltage monitoring ASIC) on the BCU, are still active.

The machine leaves energy saver mode when one of the following happens.

- Print command received from the PC
- Any operation panel keys pressed

NOTE: The machine does not leave level 2 energy saver mode when covers are opened and closed, because the CPU on the BCU is not active.

6.9 PAPER EXIT

6.9.1 OVERVIEW

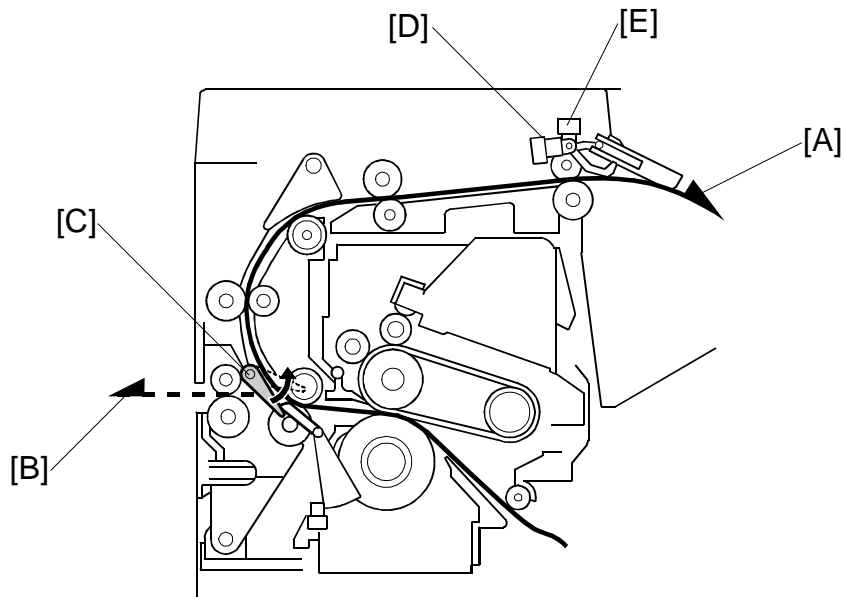

G060D504.WMF

- [A]: To standard paper tray
- [B]: To external paper tray
- [C]: Junction gate
- [D]: Paper exit sensor
- [E]: Paper overflow sensor

- After fusing, the junction gate feeds paper to the standard paper tray or the external paper tray. The junction gate solenoid controls the junction gate as follows.
 - To feed paper to the standard paper tray: The junction gate solenoid is off (default).
 - To feed paper to the external paper tray: The junction gate solenoid is on.
- The development drive roller-K drives the exit rollers.

6.9.2 PAPER OVERFLOW DETECTION

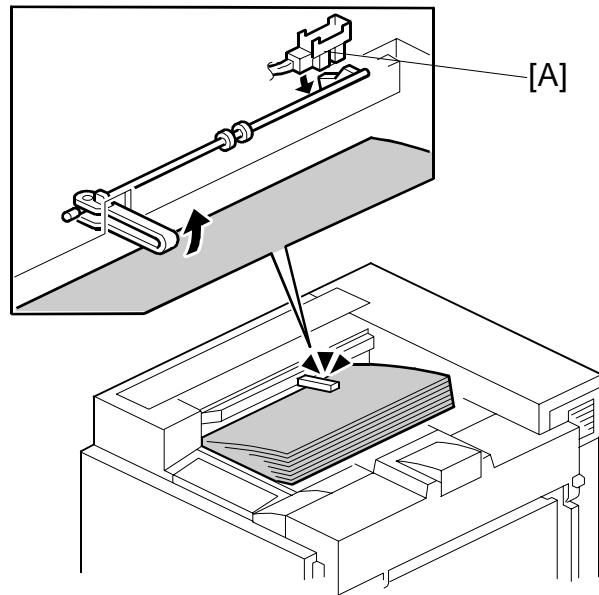

G060D601.WMF

[A]: Paper overflow sensor

- When the paper overflow sensor [A] is activated, the machine detects that the paper stack height has exceeded a certain limit and stops printing.

6.10 CONTROLLER

6.10.1 OVERVIEW

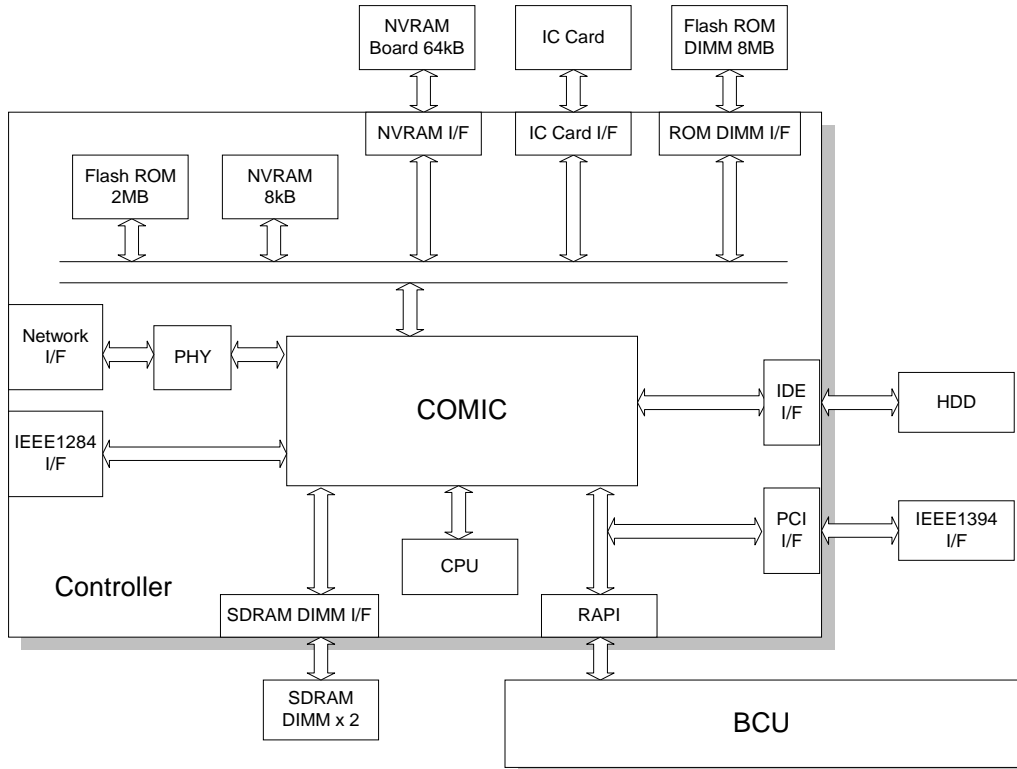

G060D553.WMF

The controller uses GW (Grand Workware) architecture.

1. **CPU:** QED RM7000 (250 MHz)
2. **COMIC (Color Model IC):** GW architecture ASIC. It uses a 100 MHz bus (64 bit) for interfacing with CPU and memory. It controls the interface with the CPU and also controls the following functions: memory, local bus, interrupts, PCI bus, video data, HDD, network, operation panel, IEEE1284, and image processing.
3. **SDRAM DIMM (2 slots):** 32 MB SDRAM (resident), expandable up to 384 MB with a 64 MB, 128 MB, or 256 MB SDRAM.
4. **Flash ROM:** 2 MB flash ROM programmed for network applications
5. **ROM DIMM (3 slots):** The DIMM installed in the machine includes 8 MB flash ROM programmed for system, printer, PCL5c, PS3, and RPCS applications. This DIMM also includes 8 kB of Mask ROM for storing internal printer fonts. Currently the remaining two DIMM slots are not being used.
6. **NVRAM:** 8 kB NVRAM for storing the printer parameters and logged data
7. **IEEE1284 Interface:** Supports compatible, nibble, and ECP modes

8. **Network Interface:** 100BASE-TX/10BASE-T
9. **NVRAM board (option):** 64 kB NVRAM used for storing a record of the number of pages printed under each "User Code".
10. **IEEE1394 Interface (option):** See the IEEE1394 Interface section.
11. **HDD (option):** A 3.5" HDD (20.5 GB) can be connected using the IDE interface. The hard disk is partitioned as shown below. The sizes cannot be adjusted.

Partition	Size	Function	Comment
File System 1	500 MB	Downloaded fonts, forms.	Remain stored even after cycling power off/on.
Image TMP	9800 MB	Collation, sample print, locked print.	Commonly used area for applications, erased after power off.
Job Log	10 MB	Job log.	Remains stored even after cycling power off/on.

The system and application software for the following boards can be downloaded from the Controller IC Card.

- Controller (Flash ROM and flash ROM DIMM)
- BCU (Main CPU and MUSIC CPU)

For details about downloading software from an IC card, see Service Tables – Firmware Update Procedure.

6.10.2 BOARD LAYOUT

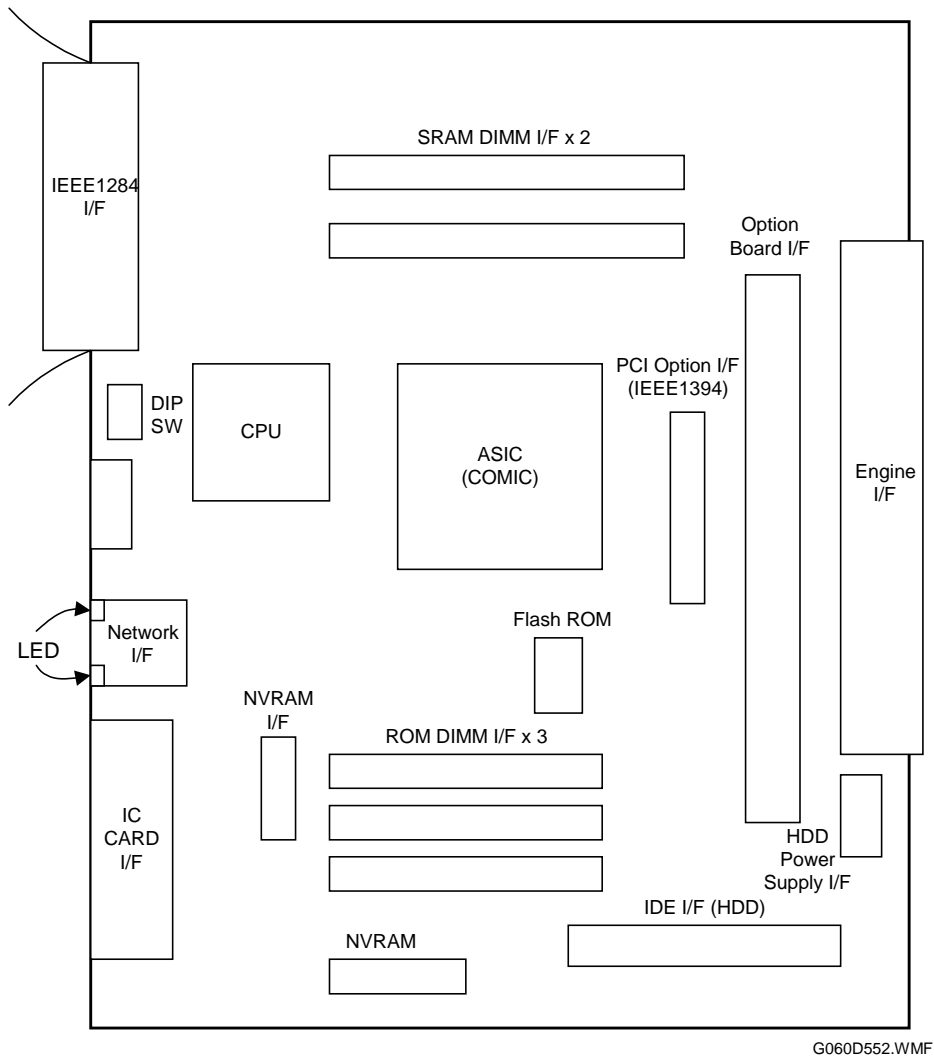

Detailed Descriptions

6.10.3 PRINT DATA PROCESSING

RPCS Driver

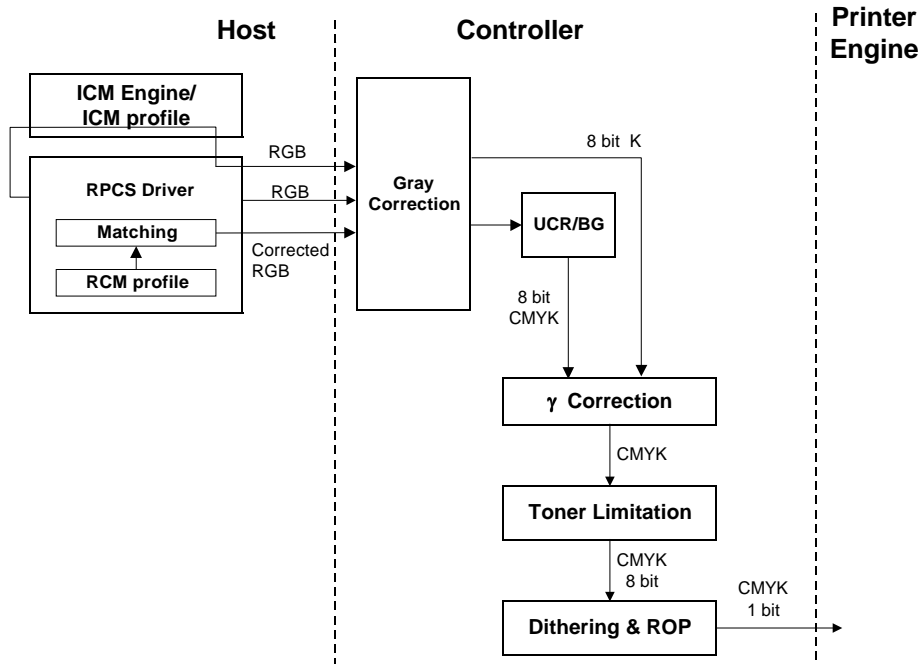

G060D562.WMF

PCL5c Driver

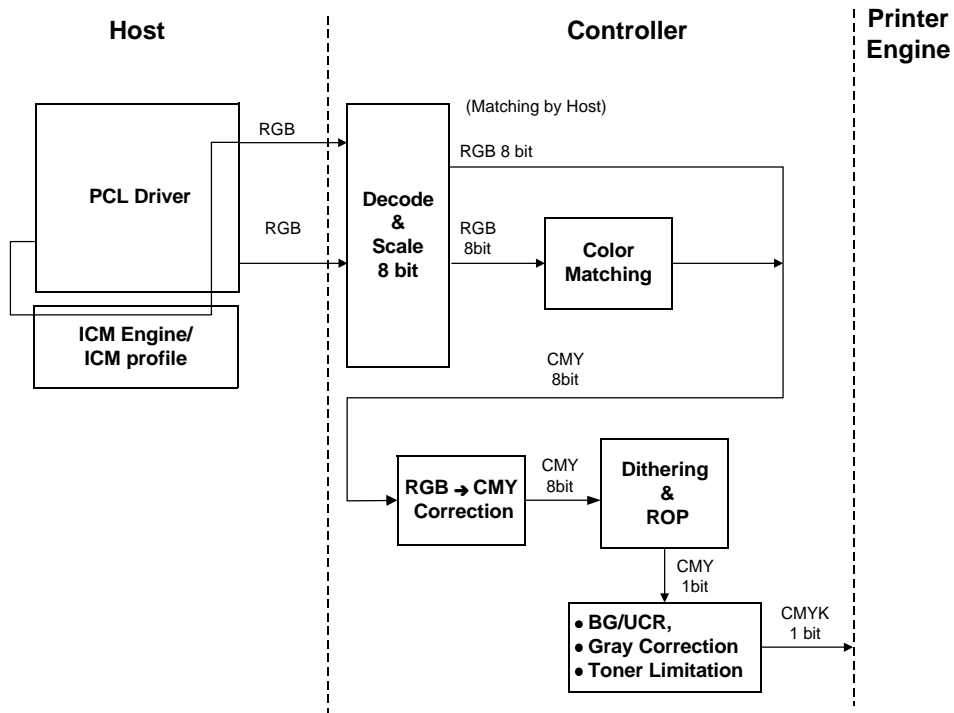

G060D563.WMF

PS3 Driver

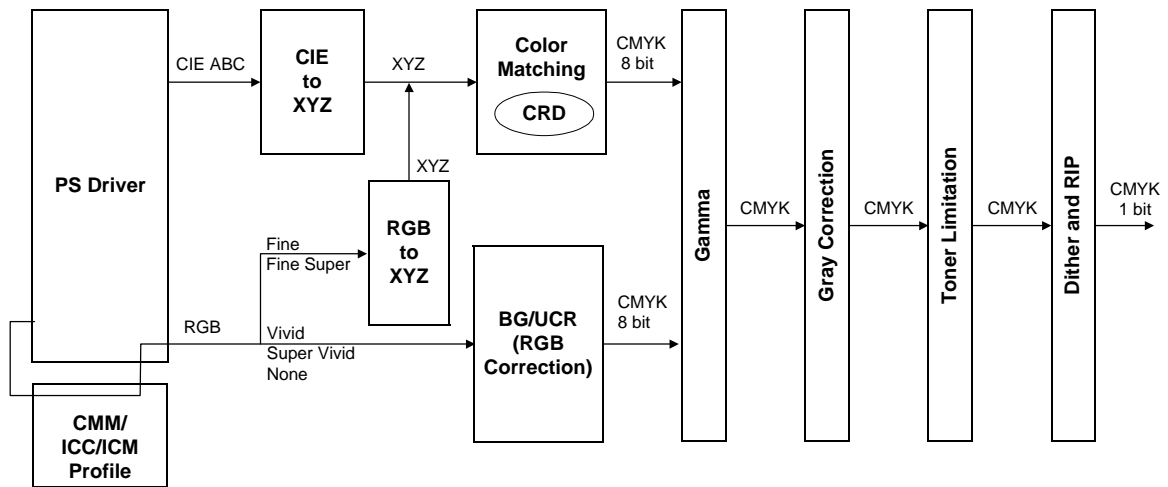

G060D564.WMF

CMS (Color Management System)

CMS optimizes the color print quality using a color profile that is based on the characteristics of the printer. With RPCS, the color profile is applied by the driver. With PS3 and PCL5c, the color profile is applied in the matching/CRD module on the controller except when using CMM/ICC/ICM profiles.

CMS is not used when the color profile setting in the printer driver is set to “Off.”

Gray Correction

Gray correction processes gray with K or CMYK toner depending on the driver settings.

BG/UCR (Black Generation/Under Color Removal)

The RGB data is converted to CMYK data with BG/UCR. During CMYK conversion, some CMY data is replaced with K data by the BG/UCR algorithm.

Gamma Correction

The printer gamma can be adjusted with controller SP mode (Gamma Adj.). For CMYK, there are 15 points between 0 and 100%. The corrected gamma data is stored in NVRAM.

Detailed Descriptions

Toner Limitation

Toner limitation prevents toner from being scattered around text or printed lines.

Maximum values have been prepared independently for text and photo. They can be adjusted with controller SP mode (Toner Limit).

- Default: 190% for text, 260% for photo
- Adjustable range: 100% to 400%

Dither Processing and ROP/RIP

Dither patterns have been prepared for photo and text independently. Dithering converts the 8-bit data to 1-bit data. However, these dither patterns create the illusion of 256 gradations for high quality prints. The optimum dither pattern is selected depending on the selected resolution.

RIP: Raster Image Processing

ROP: Raster Operation

6.10.4 CONTROLLER FUNCTIONS

Sample Print

This feature was formerly known as “Proof Print”. It requires installing an optional HDD. This function gives users a chance to check the print results before starting a multiple-set print run.

- The size of the hard disk partition for the sample print feature is 5.8 GB. This partition is also used by the collation and locked print features.
- The partition can hold up to 30 files, including files stored using locked print.
- The partition can hold a log containing up to 20 errors, excluding jobs stored using locked print.
- The maximum number of pages is 2,000, including jobs using locked print and collation.

Locked Print

This feature requires installing an optional HDD. Using this feature, the print job is stored in the machine but will not be printed until the user inputs an ID at the machine's operation panel. This ID must match the ID that was input with the printer driver.

- Stored data is automatically deleted after it is printed.
- Stored data can be manually deleted at the operation panel.
- The partition can hold up to 30 files, including files stored using sample print.
- The partition can hold a log containing up to 20 errors, excluding logs stored using locked print.
- The maximum number of pages is 2,000, including jobs using sample print and collation.
- Locked print uses the same hard disk partition as sample print and collation, which is 5.8 GB.

Paper Source Selection

Tray Priority (Auto Tray Select)

The “Tray Priority” setting determines the start of the tray search when the user selects “Auto Tray Select” with the driver. The machine searches for a paper tray with the specified paper size and type.

When no tray contains paper that matches the paper size and type specified by the driver, the controller stops printing until the user loads the correct paper.

The “Tray Priority” setting can be specified in the “Paper Input” menu. (Menu/ Paper Input/ Tray Priority)

NOTE: The by-pass feed table is not part of the tray search.

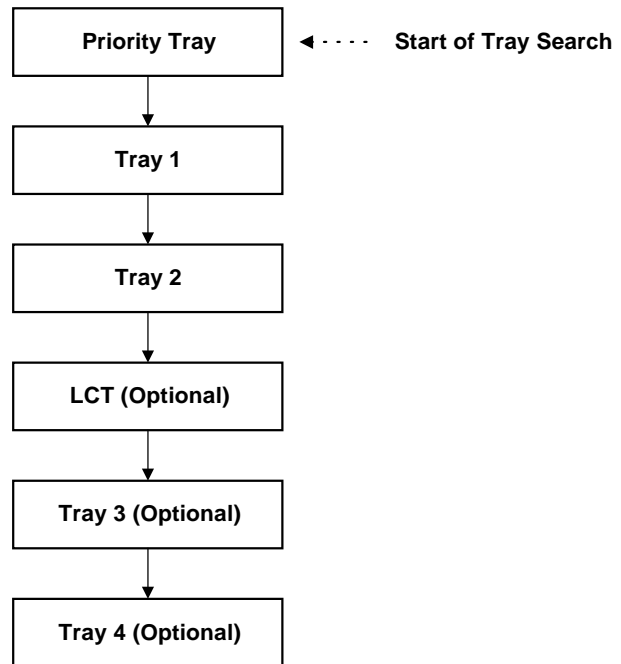

G060D555.WMF

Tray Lock

If “Tray Lock” is enabled for a tray, the controller skips the “locked” tray in the tray search process.

The “Tray Lock” setting can be specified in the “Paper Input” menu. (Menu/ Paper Input/ Tray Lock)

NOTE: The by-pass feed table cannot be unlocked (Tray Lock is always enabled).

Manual Tray Select

If the selected tray does not have the paper size and type specified by the driver, the controller stops printing until the user loads the correct paper.

Auto Continue

Overview

When this function is enabled, the machine waits for a specified period (0, 1, 5, 10, 15 minutes) for the correct paper size and type to be set in the tray. If the timer runs out, the machine starts printing, even if there is no paper tray which matches the paper size and paper type specified by the driver.

The machine searches for a paper tray in the following way.

- The interval can be set with the “System” menu in the User Tools.
(Menu/ System/ Auto Continue)

NOTE: The default setting for this feature is ‘disabled’.

Auto Tray Select

When there is no paper tray that matches the paper size and type specified by the driver, the machine searches for any tray that has paper, and prints from the first tray it finds. The start of the tray search is the tray selected as the “Priority Tray.”

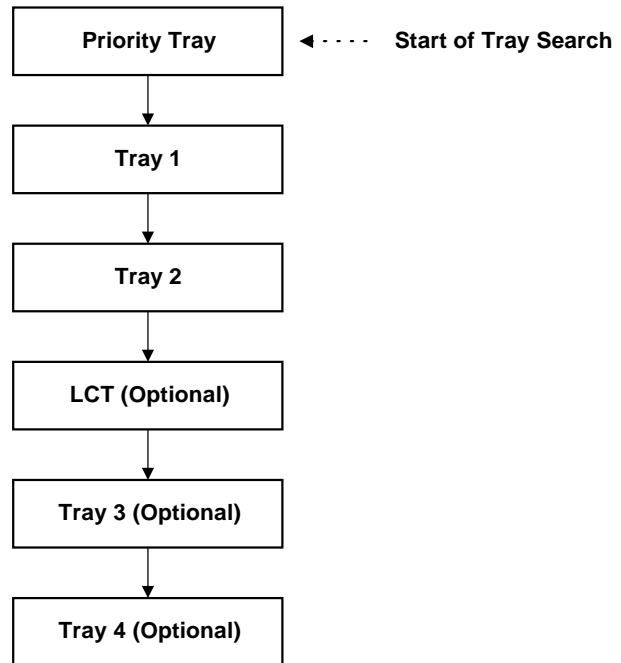

Detailed Descriptions

G060D555.WMF

Manual Tray Select

The machine prints from the selected tray even if the paper size and type do not match the setting specified from the driver.

If “Auto Continue” is disabled, the machine waits until the user loads the correct paper in the tray.

Paper Output Tray

The output tray can be selected with the “Output Tray” setting in the “System” menu (Menu/ System/ Output Tray).

If a print job does not specify an output tray or if the driver specifies the default tray, the output tray selected with this user tool will be used.

Output Tray Selected

- If the machine cannot print to the selected output tray, it prints to the default paper output tray.
- If paper overflow is detected at the selected output tray, the controller stops printing until the overflow detector goes off.

Sequential Stacking

When the 4-bin mailbox is installed, “Auto Tray SW” is selected as the output tray in the “System” menu, and “Printer Default” is specified as the output tray in the driver, the machine automatically sends the output to the lowest tray. When that tray fills up, the machine sends the output to the next lowest tray. When that tray also fills up, the machine sends the output to the next lowest tray sequentially.

This feature is called “Sequential Stacking.”

- If a tray becomes full and paper is detected in the next tray, the machine displays an error and stops printing. When paper in the next tray is removed, the machine automatically resumes printing to the next tray.
- If all trays become full (overflow detected in all trays), the machine displays an error and stops printing. This time, all paper in all trays must be removed.

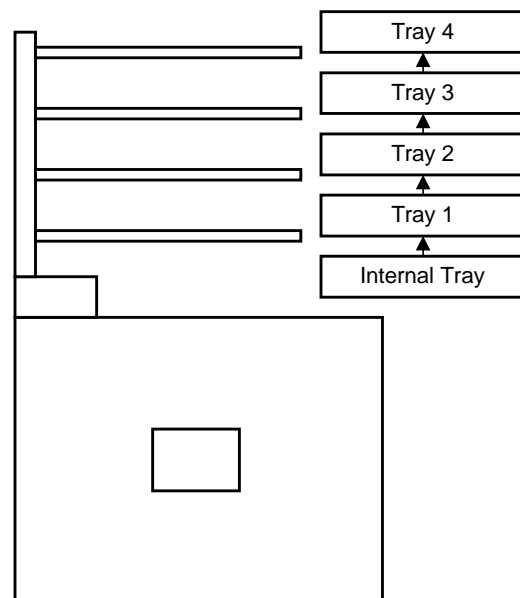

G060D556.WMF

Stapling

Stapling is available when the two-tray finisher is installed. The finisher has the following stapling positions.

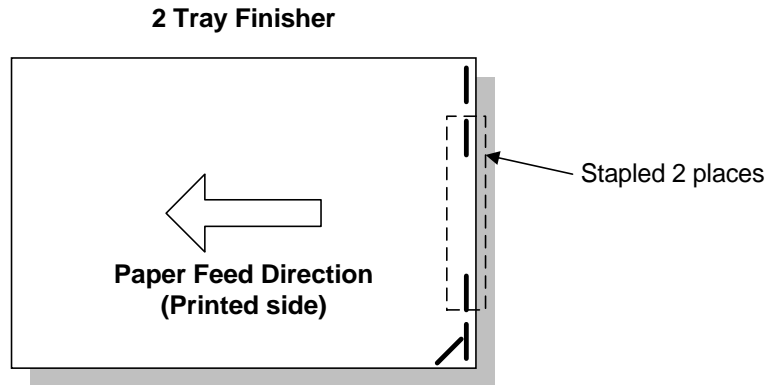

G060D557.WMF

- Depending on the paper orientation, the image may have to be rotated. The controller rotates the image. If the paper cannot be physically stapled as specified by the driver, it will not be stapled.
- There is a limit for the number of sheets which can be stapled. If a job has more than this number, it will not be stapled.
For A3, 11" x 17", 8½" x 14" paper: 30 sheets
For 8½" x 11", A4, B5 paper: 50 sheets

Punching

Punching is available only when the punch kit is installed with the two-tray finisher. The number of holes (2, 3, or 4 holes) depends on the type of punch kit.

- There is only one punch position available, so the relationship between the punching position and the printed image depends on the paper feed orientation and image rotation.

Detailed Descriptions

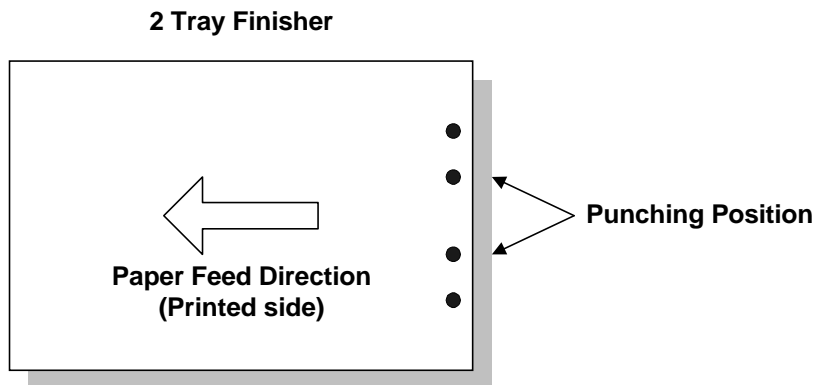

G060D558.WMF

6.11 IEEE1394 INTERFACE

6.11.1 SPECIFICATIONS

Hardware Specification

Interface: IEEE1394 (6 pins)
 (no power supply, cable power repeated, IEEE1394a-2000 compliant)
 Ports: 2 ports
 Data rates: 400Mbps/200Mbps/100Mbps

System Requirements

PC: Windows PC with IEEE1394 port
 OS: Microsoft Windows 2000 upgraded with service pack 1
 Cable length: 4.5m (15ft)

6.11.2 IEEE1394

IEEE1394, also known as FireWire (a name patented by Apple), is an easy-to-use peer-to-peer networking technology allowing speeds of up to 400 Mbps.

The current standard contains the following features, which are supported in most devices:

- Hot swapping (cables can be connected and disconnected while the computer and other devices are switched on)
- Peer-to-peer networking (no hub required)
- No terminator or device ID is required, unlike SCSI
- Automatic configuration of devices upon start-up, or “plug and play.”
- Real-time data transfer at 100, 200, and 400 Mbps
- Common connectors for different devices

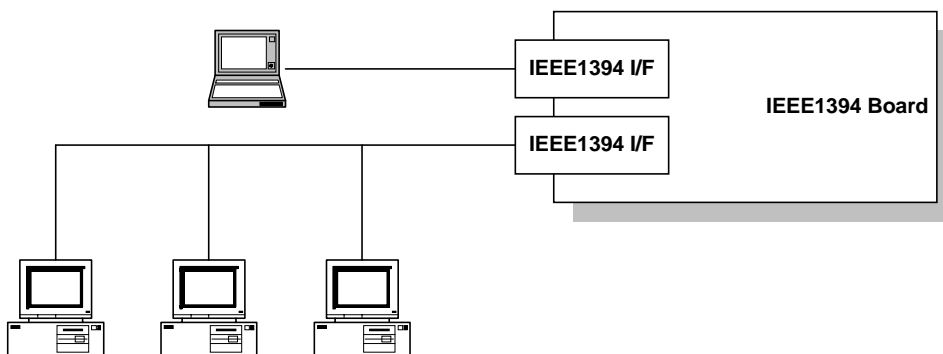

G060D559.WMF

The cable length is limited to 4.5 m (15ft). However, up to 16 cables and 63 devices can be connected to an IEEE1394 network.

IEEE1394 cables can be either 4-pin (data only) or 6-pin (data and power). IEEE1394 allows either 6-pin or 4-pin connectors. However, this machine only uses the 6-pin connectors. The machine has two 6-pin ports.

6.11.3 BLOCK DIAGRAM

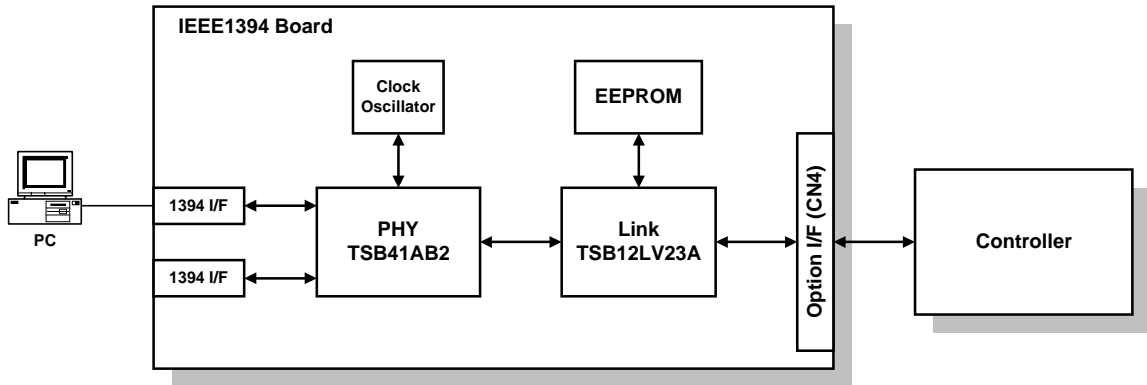

G060D560.WMF

- PHY: Physical layer control device
- Link: Link layer control device
- EEPROM: 256-byte ROM

6.11.4 PIN ASSIGNMENT

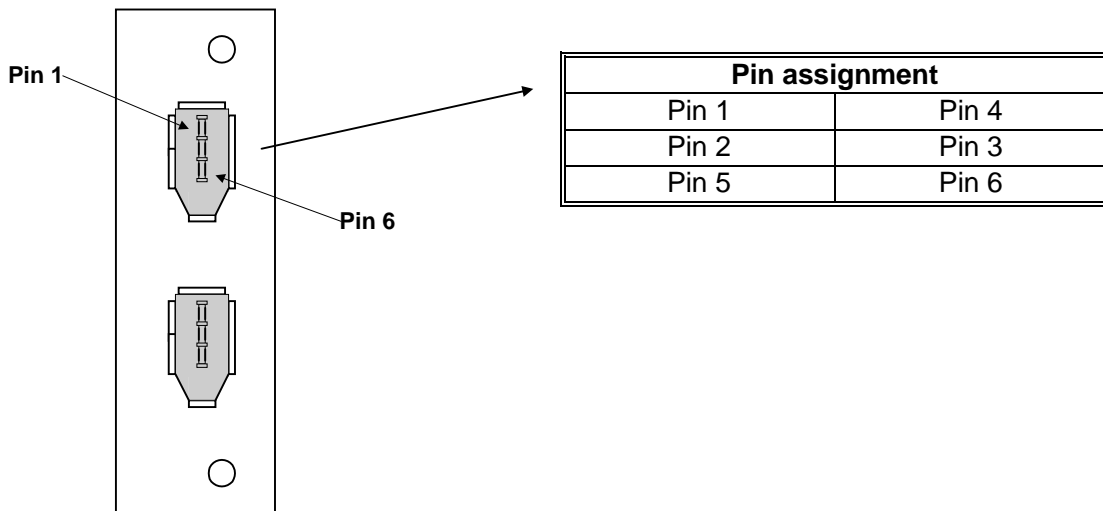

G060D561.WMF

Pin No.	Signal Description
1	Cable Power
2	GND
3	Receive strobe
4	Transmit data
5	Receive data
6	Transmit strobe

Detailed Descriptions

6.11.5 REMARKS ABOUT THIS INTERFACE KIT

Note the following points about this unit.

- The machine does not print reports specifically for IEEE1394. Just print the Configuration Page at installation to check that the machine recognizes the card.
- There is no spooler or print queue. If a computer tries to print over the IEEE1394 while the printer is busy, the IEEE1394 interface card inside the printer will return a busy signal.
- After starting a job using IEEE1394, do not switch the printer off until the job has been completed. Even though the printer may appear to be dead, it may be in the middle of an IEEE1394 protocol exchange with the computer.
- When using IEEE1394, it is not possible to check the printer status from the computer with a utility such as Printer Manager for Client.

6.11.6 TROUBLESHOOTING NOTES

If there are problems printing using the IEEE1394 interface, check the following.

- Is the computer using Windows 2000 with service pack 1?
- Has the interface card been replaced recently? Each card has an individual address, similar to the MAC address in an Ethernet card. If the card was changed, the driver cannot find the old card. The new card is another device and a new printer appears in Windows Control panel, and this must be configured in the same way as the printer that was replaced (the old printer icon in Windows Control Panel should be deleted) has to be reconfigured.
- Is there a loop somewhere in the network? An IEEE1394 network must be a chain or a branched chain. There can be no loops.
- Try to find out where in the chain the problem is occurring. Test the machine one-to-one with the computer to determine if the printer is defective (when the printer's interface cable is plugged in, the computer should see 'Printer Ready'; when the cable is disconnected, the computer should see 'Offline').

SPECIFICATIONS

1. GENERAL SPECIFICATIONS

Configuration:	Desktop
Print Process:	Dry electrostatic transfer system
Printer Languages:	PCL5c Adobe PostScript 3 RPCS (Refined Printing Command Stream)
Resolution:	PCL5c: 600 x 600 dpi, 300 x 300 dpi Adobe PostScript 3: 1200 x 1200 dpi, 1200 x 600 dpi, 600 x 600 dpi RPCS: 1200 x 1200 dpi, 1200 x 600 dpi, 600 x 600 dpi
Gradation	1 bit/pixel
Printing speed:	

	Resolution	Plain paper	Thick/OHP
Monochrome	600 x 600 dpi	38 ppm	10 ppm
	1200 x 600 dpi	38 ppm	10 ppm
	1200 x 1200 dpi	28 ppm	10 ppm
Color	600 x 600 dpi	28 ppm	10 ppm
	1200 x 600 dpi	28 ppm	10 ppm
	1200 x 1200 dpi	14 ppm	10 ppm

Resident Fonts:	PCL5c: 35 Intelli fonts 10 TrueType fonts 1 bitmap font Adobe PostScript 3: 136 fonts (24 Type 2 fonts, 112 Type 14 fonts)
Host Interfaces:	Bi-directional IEEE1284 parallel x 1: Standard Ethernet (100 Base-TX/10 Base-T): Standard IEEE1394: Optional
Network Protocols:	TCP/IP, IPX/SPX, NetBEUI, AppleTalk
First Print Speed:	Color: 9 seconds or less (from tray 1) Monochrome: 7 seconds or less (from tray 1)
Warm-up Time	Less than 120 seconds (at 23°C/50%)
Print Paper Capacity:	Standard tray: 500 sheets x 2 By-pass tray: 100 sheets Optional paper feed tray: 500 sheets x 1, 500 sheets x 2, Optional LCT: 2000 sheets

Print Paper Size: (Refer to "Supported Paper Sizes".)

	Minimum	Maximum
Tray 1	A4/8½" x 11" (LEF)	
Tray 2	A5 (LEF)/8½" x 11"	A3/11" x 17"
By-pass	90 x 148 mm	305 x 458 mm/12" x 18"
Optional Tray	A5 (LEF)/8½" x 11"	A3/11" x 17"
LCT	A4/8½" x 11" (LEF)	

Printing Paper Weight: Standard tray: 60 to 105 g/m² (16 to 28 lb.)
 Optional paper tray: 60 to 105 g/m² (16 to 28 lb.)
 By-pass tray: 60 to 163 g/m² (16 to 43 lb.)

Output Paper Capacity: Standard exit tray: 500 sheets (face down)
 External exit tray: 100 sheets (face up)

Memory: Standard 32 MB, up to 384 MB with optional DIMM

Power Source: 120 V, 60 Hz: More than 10 A (for North America)
 220 V - 240 V, 50/60 Hz: More than 6.0 A (for Europe)

Power Consumption:

	120V	230V
Maximum	1200 W or less	1300 W or less
Energy Saver	45 W or less	45 W or less

Noise Emission:

(Sound Power Level)

	Mainframe Only	Full System
Printing	68 dB or less	72 dB or less
Stand-by	42 dB or less	
Low power mode	40 dB or less	

NOTE: The above measurements were made in accordance with Ricoh standard methodology.

Dimensions (W x D x H): 578 x 648 x 715 mm (22.7" x 25.6" x 28.2")

Weight: Less than 77 kg (170 lb.)

1.1 SUPPORTED PAPER SIZES

1.1.1 PAPER FEED

Paper	Size (W x L)	North America			Europe/Asia			By-pass Tray
		Tray 1	Tray 2/3/4	LCT	Tray 1	Tray 2/3/4	LCT	
A3 W	12" x 18"	N	N	N	N	N	N	Y [#]
A3 SEF	297 x 420 mm	N	Y	N	N	Y	N	Y [#]
A4 SEF	210 x 297 mm	N	Y [#] /Y [*]	N	N	Y	N	Y [#]
A4 LEF	297 x 210 mm	Y [*]	Y	Y [*]	Y	Y	Y	Y [#]
A5 SEF	148 x 210 mm	N	N	N	N	N	N	Y [#]
A5 LEF	210 x 148 mm	N	Y	N	N	Y	N	Y [#]
A6 SEF	105 x 148 mm	N	N	N	N	N	N	Y [#]
B4 SEF	257 x 364 mm	N	Y [#] /Y [*]	N	N	Y	N	Y [#]
B5 SEF	182 x 257 mm	N	Y [#] /Y [*]	N	N	Y [#] /Y [*]	N	Y [#]
B5 LEF	257 x 182 mm	N	Y	N	N	Y	N	Y [#]
B6 SEF	128 x 182 mm	N	N	N	N	N	N	Y [#]
Ledger	11 x 17"	N	Y	N	N	Y	N	Y [#]
Letter SEF	8.5 x 11"	N	Y	N	N	Y [#] /Y [*]	N	Y [#]
Letter LEF	11 x 8.5"	Y	Y	Y	Y [*]	Y	Y [*]	Y [#]
Legal SEF	8.5 x 14"	N	Y	N	N	Y [#] /Y [*]	N	Y [#]
Half Letter SEF	5.5 x 8.5"	N	N	N	N	N	N	Y [#]
Executive SEF	7.25 x 10.5"	N	Y [#]	N	N	Y [#]	N	Y [#]
Executive LEF	10.5 x 7.25"	N	N	N	N	N	N	Y [#]
F SEF	8 x 13"	N	Y [#]	N	N	Y [#]	N	Y [#]
Foolscap SEF	8.5 x 13"	N	Y [#]	N	N	Y [#]	N	Y [#]
Folio SEF	8.25 x 13"	N	Y [#]	N	N	Y [#]	N	Y [#]
8K	267 x 390 mm	N	Y [#]	N	N	Y [#]	N	Y [#]
16K SEF	195 x 267 mm	N	Y [#]	N	N	Y [#]	N	Y [#]
16K LEF	267 x 195 mm	N	Y [#]	N	N	Y [#]	N	Y [#]
Custom	Minimum: 90 x 148 mm Maximum: 305 x 458 mm	N	N	N	N	N	N	Y [#]
Com10 Env.	4.125 x 9.5"	N	N	N	N	N	N	Y [#]
Monarch Env.	3.875 x 7.5"	N	N	N	N	N	N	Y [#]
C6 Env.	114 x 162 mm	N	N	N	N	N	N	Y [#]
C5 Env.	162 x 229 mm	N	N	N	N	N	N	Y [#]
DL Env.	110 x 220 mm	N	N	N	N	N	N	Y [#]

Remarks:

Y	Supported: the sensor detects the paper size.
Y [#]	Supported: the user specifies the paper size.
Y [*]	Supported: depends on a technician adjustment
N	Not supported

Spec.

1.1.2 PAPER EXIT

Paper	Size (W x L)	Internal Tray (Face Down)	External Tray (Face Up)	Finisher	4-bin Mailbox	Duplex
A3 W	12" x 18"	N	Y	N	N	N
A3 SEF	297 x 420 mm	Y	Y	Y	Y	Y
A4 SEF	210 x 297 mm	Y	Y	Y	Y	Y
A4 LEF	297 x 210 mm	Y	Y	Y	Y	Y
A5 SEF	148 x 210 mm	Y	Y	N	Y	N
A5 LEF	210 x 148 mm	Y	Y	Y	Y	Y
A6 SEF	105 x 148 mm	Y	Y	N	N	N
B4 SEF	257 x 364 mm	Y	Y	Y	Y	Y
B5 SEF	182 x 257 mm	Y	Y	Y	Y	Y
B5 LEF	257 x 182 mm	Y	Y	Y	Y	Y
B6 SEF	128 x 182 mm	Y	Y	N	N	N
Ledger	11 x 17"	Y	Y	Y	Y	Y
Letter SEF	8.5 x 11"	Y	Y	Y	Y	Y
Letter LEF	11 x 8.5"	Y	Y	Y	Y	Y
Legal SEF	8.5 x 14"	Y	Y	Y	Y	Y
Half Letter SEF	5.5 x 8.5"	Y	Y	N	Y	N
Executive SEF	7.25 x 10.5"	Y	Y	Y	Y	Y
Executive LEF	10.5 x 7.25"	Y	Y	N	N	N
F SEF	8 x 13"	Y	Y	Y	Y	Y
Foolscap SEF	8.5 x 13"	Y	Y	Y	N	Y
Folio SEF	8.25 x 13"	Y	Y	Y	N	Y
8K	267 x 390 mm	Y	Y	Y	N	Y
16K SEF	195 x 267 mm	Y	Y	Y	Y	Y
16K LEF	267 x 195 mm	Y	Y	Y	Y	Y
Custom	Minimum: 90 x 148 mm Maximum: 305 x 458 mm	Y	Y	N	Y	N
Com10 Env.	4.125 x 9.5"	N	Y	N	N	N
Monarch Env.	3.875 x 7.5"	N	Y	N	N	N
C6 Env.	114 x 162 mm	N	Y	N	N	N
C5 Env.	162 x 229 mm	N	Y	N	N	N
DL Env.	110 x 220 mm	N	Y	N	N	N

Remarks:

Y	Supported
N	Not supported

2. SOFTWARE ACCESSORIES

The printer drivers and utility software are provided on one CD-ROM. An auto-run installer allows you to select which components to install.

2.1 PRINTER DRIVERS

Printer Language	Windows 95/98/ME	Windows NT4.0	Windows 2000	Macintosh
PCL 5c	Yes	Yes	Yes	No
PS3	Yes	Yes	Yes	Yes
RPCS	Yes	Yes	Yes	No

- NOTE:**
- 1) The printer drivers for Windows NT 4.0 are only for the Intel x86 platform. There is no Windows NT 4.0 printer driver for the PowerPC, Alpha, or MIPS platforms.
 - 2) The PS3 drivers are all genuine AdobePS drivers, except for Windows 2000, which uses Microsoft PS. A PPD file for each operating system is provided with the driver.
 - 3) The PS3 driver for Macintosh supports Mac OS 7.6 or later versions.

2.2 UTILITY SOFTWARE

Software	Description
Agfa Font Manager 2000 (Win95/98, 2000, NT4)	A font management utility with screen fonts for the printer.
SmartNetMonitor for Admin (Win95/98, 2000, NT4)	A printer management utility for network administrators. NIB setup utilities are also available.
SmartNetMonitor for Client (Win95/98, 2000, NT4)	<ul style="list-style-type: none"> • A printer management utility for client users. • A utility for peer-to-peer printing over a NetBEUI or TCP/IP network. • A peer to peer print utility over a TCP/IP network. This provides the parallel printing and recovery printing features.
Printer Utility for Mac (Mac)	This software provides several convenient functions for printing from Macintosh clients.
IEEE1394 Utility (Win2000)	This utility solves problems with Windows 2000.
DeskTopBinder V2 Lite (Win95/98, 2000, NT4)	DeskTopBinder V2 Lite itself can be used as personal document management software and can manage both image data converted from paper documents and application files saved in each client's PC.

3. MACHINE CONFIGURATION

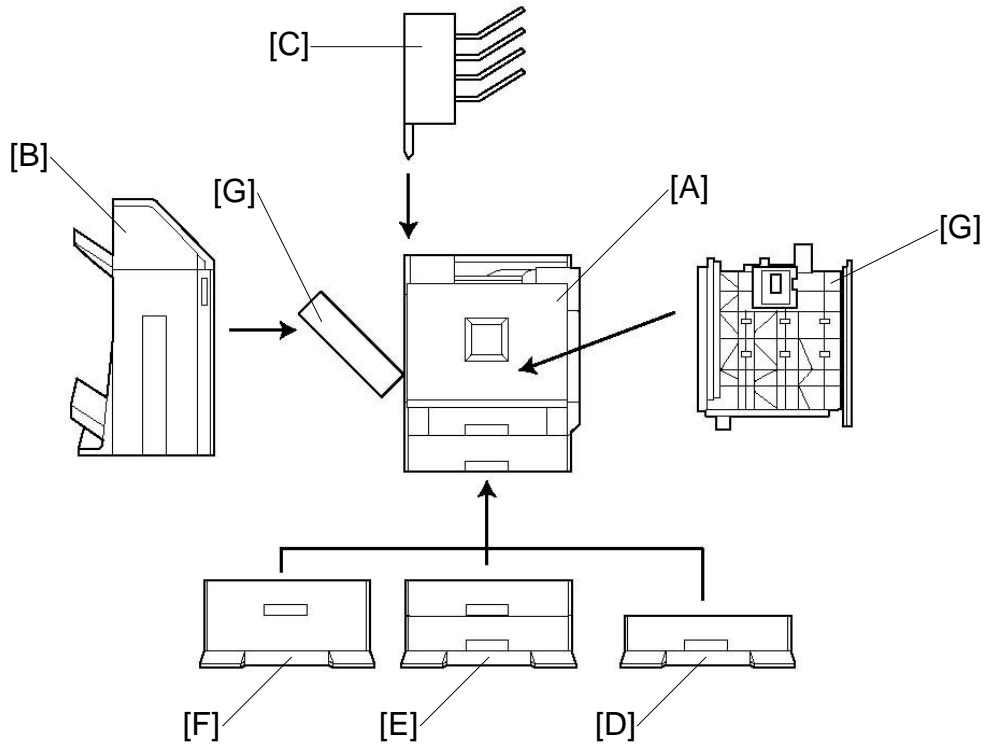

G060V112.JPG

Item	Machine Code	No.	Remarks
Main Unit	G060	A	
Options			
Finisher	G565	B	Requires the HDD or 128MB DIMM memory, duplex unit and one of the three paper feed options. Finisher and mailbox cannot both be installed.
Four-bin Mailbox	G566	C	Finisher and mailbox cannot both be installed.
Paper Feed Unit (500 x 1)	G567	D	Install any one of these three units.
Paper Feed Unit (500 x 2)	G568	E	
LCT	G569	F	
Duplex Unit	G571	G	
Punch Unit	B377		Requires the finisher
Internal Options			
64MB DIMM Memory	G579		
128MB DIMM Memory	G580		
256MB DIMM Memory	G581		
NVRAM Memory	G311		
IEEE1394 I/F Board	G590		At least 64 MB of DIMM is required
HDD Type 1	G308		
Others			

Item	Machine Code	No.	Remarks
Maintenance Kit A	G763		Includes CMY PCUs.
Maintenance Kit B	G764		Includes CMY development units.
Maintenance Kit C	G765		Includes the fusing unit.
Maintenance Kit D	G766		Includes K development unit and dust filter.
Maintenance Kit E	G767		Includes the used toner bottle.
Maintenance Kit F	G773		Includes the K PCU.
Maintenance Kit G	G774		Includes the fusing oil supply unit.
Maintenance Kit H	TBA		Includes the feed roller, pick-up roller, and separation roller.

NOTE: All the above items are user installable except for the punch unit.

4. OPTIONAL EQUIPMENT

4.1 500-SHEET TRAY

Paper Size:	Maximum: A3/11" x 17" (SEF) Minimum: A5 (LEF)/8½" x 11"
Paper Weight:	60 to 105 g/m ² (16 to 28 lb.)
Tray Capacity:	500 sheets (80 g/m ² , 20 lb.)
Paper Feed System:	FRR system
Paper Height Detection:	3 steps (100%, 50%, Near End)
Power Source:	DC 24V, 5V (from the main unit)
Power Consumption:	50 W
Dimensions (W x D x H):	540 x 600 x 172 mm (21.3" x 23.7" x 6.8")
Weight	18 kg (39.7 lb.)

4.2 1000-SHEET TRAY

Paper Size:	Maximum: A3/11" x 17" (SEF) Minimum: A5 (LEF)/8½" x 11"
Paper Weight:	60 to 105 g/m ² (16 to 28 lb.)
Tray Capacity:	500 sheets x 2 (80 g/m ² , 20 lb.)
Paper Feed System:	FRR system
Paper Height Detection:	3 steps (100%, 50%, Near End)
Power Source:	DC 24V, 5V (from the main unit)
Power Consumption:	50 W
Dimensions (W x D x H):	540 x 600 x 270 mm (21.3" x 23.7" x 10.7")
Weight	25 kg (55.2 lb.)

4.3 2000-SHEET LARGE CAPACITY TRAY

Paper Size:	A4/8½" x 11" (LEF)
Paper Weight:	60 to 105 g/m ² (16 to 28 lb.)
Tray Capacity:	2000 sheets (80 g/m ² , 20 lb.)
Paper Feed System:	FRR system
Paper Height Detection:	5 steps (100%, 75%, 50%, 25%, Near End)
Power Source:	DC 24V, 5V (from the main unit)
Power Consumption:	30 W

Dimensions (W x D x H): 540 x 600 x 270 mm (21.3" x 23.7" x 10.7")

Weight 25 kg (55.2 lb.)

4.4 TWO-TRAY FINISHER & PUNCH UNIT

Print Paper Size:	<p>No punch mode: A3/11" x 17" to A5 (LEF)/8½" x 11"</p> <p>Punch mode: 2 holes: A3/11" x 17" to A4/8½" x 11" (SEF) A4/8½" x 11" to A5 (LEF) 3 holes: A3, B4, 11" x 17" (SEF) A4, B5, 8½" x 11" (LEF) 4 holes (Europe): A3, B4, 11" x 17" (SEF) A4, B5, 8½" x 11" (LEF) 4 holes (North Europe): A3, B4, 11" x 17" (SEF) A4, B5, 8½" x 11" (LEF)</p> <p>Staple mode: A3/11" x 17" to B5/8½" x 11"</p>
Paper Weight:	<p>No punch mode: 60 to 105 g/m² (16 to 28 lb.)</p> <p>Punch mode: 60 to 105 g/m² (16 to 28 lb.)</p> <p>Staple mode: 64 to 90 g/m² (17 to 23 lb.) Label/Thick paper/OHP cannot be stapled</p>
Tray Capacity:	<p>Upper tray: 500 sheets: A4, 8½" x 11" , B5, A5 (LEF) 250 sheets: 11" x 17", A3, 8½" x 14", B4</p> <p>Lower tray (default mode – stapled output only goes to tray 2): 2000 sheets: A4, 8½" x 11" (LEF) 750 sheets: A3, B4, A4, B5, 8½" x 14", 11" x 17", 8½" x 11" (SEF) 500 sheets: A5 (LEF)</p> <p>Lower tray (multi-tray staple mode – stapled output can go to either tray): 1500 sheets: A4, 8½" x 11" (LEF) 750 sheets: A3, B4, A4, B5, 8½" x 14", 11" x 17", 8½" x 11" (SEF) 500 sheets: A5 (LEF)</p>
Staple capacity:	<p>Single size: 50 sheets: A4, 8½" x 11" , B5 30 sheets: A3, B4, 8½" x 14", 11" x 17"</p> <p>Mixed size: 30 sheets: A4 (LEF) & A3, B5 (LEF) & B4, 8½" x 11" (LEF) & 11" x 17"</p>

Staple position:	7 positions 1-staple: 4 positions (Top Left, Top Right, Top Left-Oblique, Top Right-Oblique) 2-staples: 3 positions (Left, Top, Right)
Staple replenishment:	Cartridge (5000 staples)
Power consumption:	48 W
Dimensions (W x D x H):	680 x 620 x 1030 mm (26.8" x 24.4" x 40.6")
Weight	Without punch unit: 53 kg (116.9 lb.) With punch unit: 55 Kg (121.3 lb.)

4.5 FOUR-BIN MAILBOX

Number of bins	4 bins
Stack Capacity:	125 sheets x 4 (80 g/m ² , 20 lb.)
Paper Size for Trays:	Maximum: A3/11" x 17" (SEF) Minimum: A5 (LEF)/8½" x 11"
Print Paper Weight:	60 to 105 g/m ² (16 to 28 lb.)
Power Source:	DC 24V, 5V (from the main unit)
Power Consumption:	17 W
Dimensions (W x D x H):	540 x 600 x 400 mm (21.3" x 23.6" x 15.8") (when installed in the machine)
Weight	7 kg (15.5 lb.)

ELECTRICAL COMPONENT LAYOUT (G060)

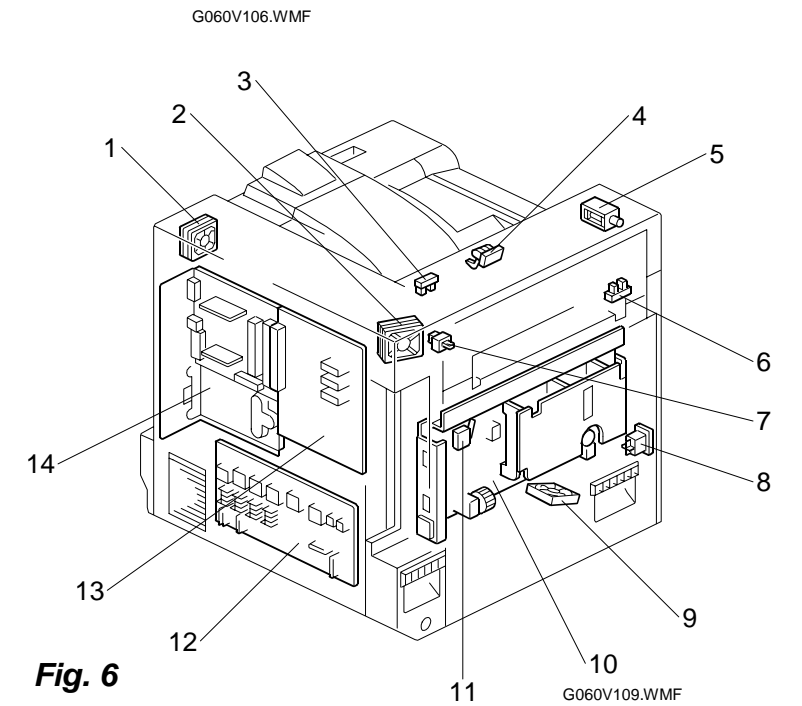
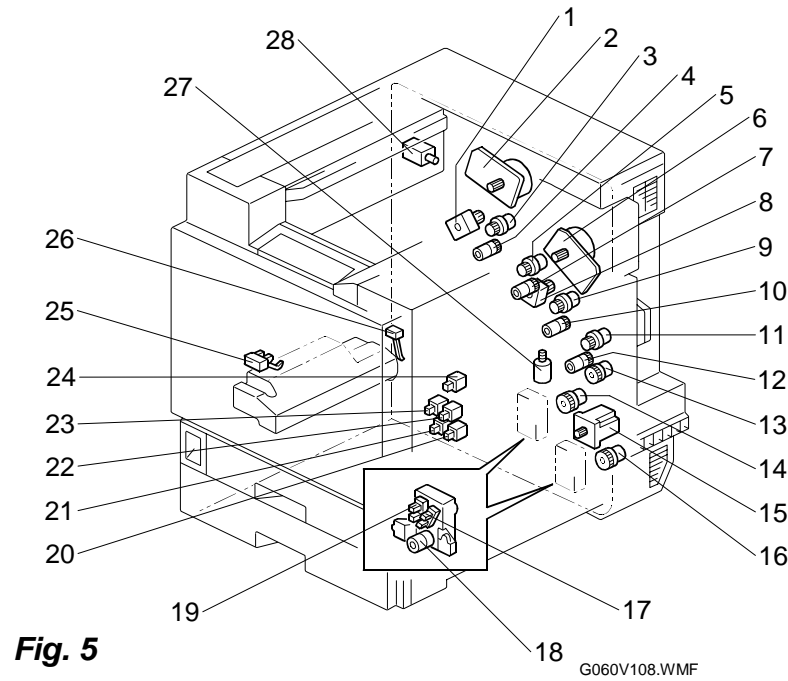
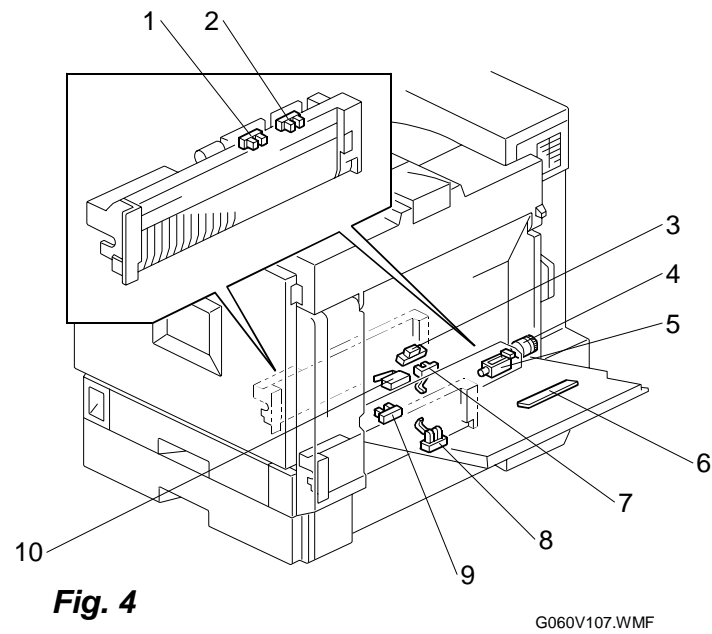
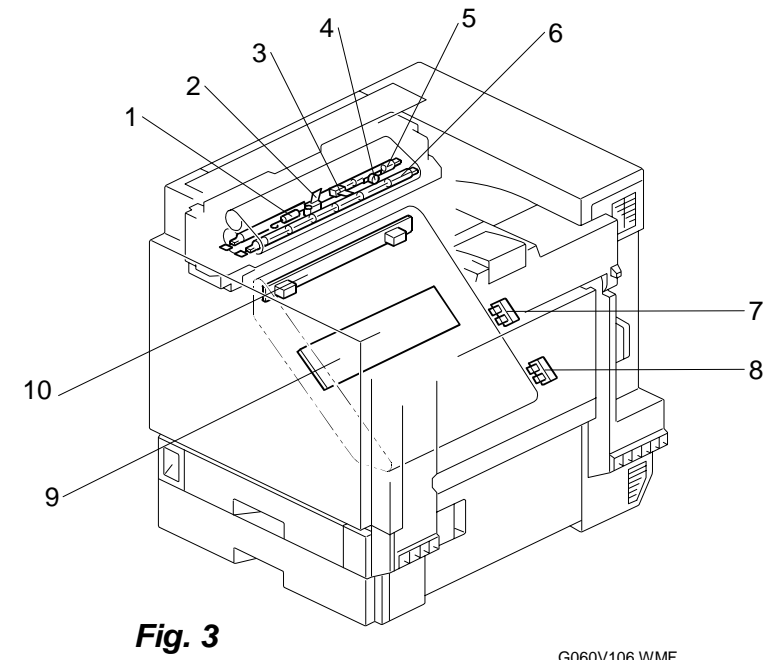
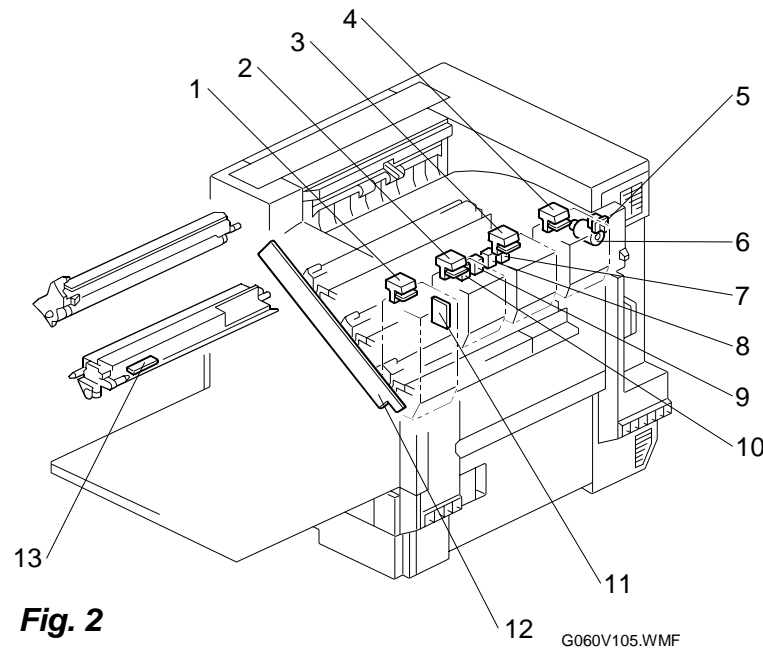
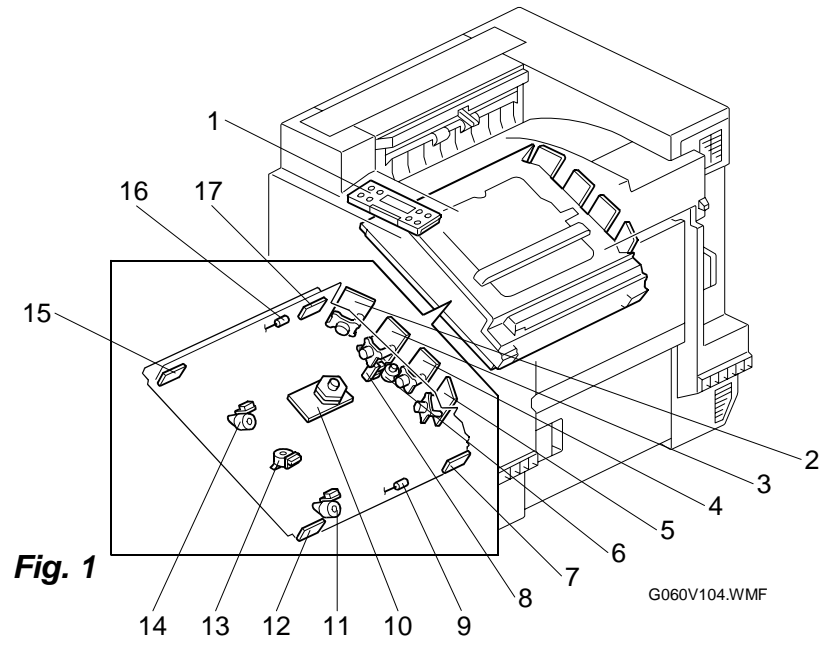

Symbol	Description	Index No.	P-to-P
Printed Circuit Boards			
PCB1	Operation Panel	1-1	H7
PCB2	LD Unit-Y	1-2	J5
PCB3	LD Unit-K	1-3	J5
PCB4	LD Unit-M	1-4	I5
PCB5	LD Unit-C	1-5	I5
PCB6	Laser Synchronizing Detector Board-MC - S	1-7	I4
PCB7	Laser Synchronizing Detector Board-MC - E	1-12	I4
PCB8	Laser Synchronizing Detector Board-YK - S	1-15	J4
PCB9	Laser Synchronizing Detector Board-YK - E	1-17	J4
PCB10	Memory Chip - K	2-1	D7
PCB11	Memory Chip - Y	2-2	D5
PCB12	Memory Chip - C	2-3	D5
PCB13	Memory Chip - M	2-4	E5
PCB14	High Voltage Supply Board - T, PA, CL	3-9	G4
PCB15	Paper Width Detection Board	4-6	E7
PCB16	PSU (Power Supply Unit)	6-10	D2
PCB17	High Voltage Supply Board - C, B	6-12	E4
PCB18	BCU	6-13	F6
PCB19	Controller	6-14	B1
Motors			
M1	LD Positioning Motor	1-6	G5
M2	Polygon Motor	1-10	H5
M3	3rd Mirror Positioning Motor-M	1-11	H5
M4	3rd Mirror Positioning Motor-C	1-13	H5
M5	3rd Mirror Positioning Motor-Y	1-14	H5
M6	Air Pump	2-6	F7
M7	Drum Drive Motor-K	5-1	B5

Symbol	Description	Index No.	P-to-P
M8	Development Drive Motor-K	5-2	A4
M9	Development Drive Motor-CMY	5-6	A4
M10	Drum Drive Motor-CMY	5-8	B5
M11	Paper Feed Motor	5-15	B5
M12,13	Tray Lift Motor	5-18	G7
M14	Transfer Belt Contact Motor	5-27	F7
M15	Laser Optics Housing Cooling Fan Motor	6-1	F7
M16	Fusing Fan Motor	6-2	C5
M17	PSU Cooling Fan Motor	6-9	D5
Sensors			
S1	LD H.P. Sensor	1-8	G5
S2	Humidity Sensor	2-11	F6
S3	TD Sensor - M	2-13	E7
S4	TD Sensor - C	2-13	C7
S5	TD Sensor - Y	2-13	C7
S6	TD Sensor - K	2-13	C7
S7	Transfer Belt Contact Sensor	3-7	B7
S8	Transfer Belt H.P. Sensor	3-8	C7
S9	ID Sensor	3-10	F4
S10,11	Paper End Sensor	4-1	J7
S12,13	Paper Lift Sensor	4-2	J7
S14	Registration Sensor	4-3	E7
S15	Relay Sensor	4-7	J7
S16	Vertical Transport Sensor	4-8	I7
S17	By-pass Paper End Sensor	4-9	E7
S18	Tray 1 Paper Height Sensor 2	5-17	G6
S19	Tray 2 Paper Height Sensor 2	5-17	G6
S20	Tray 1 Paper Height Sensor 1	5-19	G6

Symbol	Description	Index No.	P-to-P
S21	Tray 2 Paper Height Sensor 1	5-19	G6
S22	Used Toner Sensor	5-25	B7
S23	Paper Exit Sensor	6-3	C5
S24	Paper Overflow Sensor	6-4	D5
S25	Fusing Exit Sensor	6-6	D5
Switches			
SW1	Right Door Switch	2-5	F7
SW2	PCU/Development Unit Set Switch	2-12	D7
SW3	Vertical Transport Switch	4-10	D4
SW4	Tray 2 Paper Size Switch - 4	5-20	G6
SW5	Tray 2 Paper Size Switch - 2	5-21	G6
SW6	Tray 2 Paper Size Switch - 3	5-22	G6
SW7	Tray 2 Paper Size Switch - 1	5-23	G6
SW8	Tray 1 Set Switch	5-24	H6
SW9	Used Toner Bottle Set Switch	5-26	B7
SW10	Left Door Switch	6-7	D5
SW11	Main Switch	6-8	E4
SW12	Front Door and Left Door Switch	6-11	D1
Clutches			
MC1	By-pass Feed Clutch	4-4	E6
MC2	Development Clutch-K	5-3	B7
MC3	Toner Supply Clutch-K	5-4	C7
MC4	Development Clutch-Y	5-5	B7
MC5	Toner Supply Clutch-Y	5-7	C7
MC6	Development Clutch-C	5-9	B7
MC7	Toner Supply Clutch-C	5-10	C7
MC8	Development Clutch-M	5-11	D7

Symbol	Description	Index No.	P-to-P
MC9	Toner Supply Clutch-M	5-12	D7
MC10	Registration Clutch	5-13	F7
MC11	Tray 1 Paper Feed Clutch	5-14	J7
MC12	Tray 2 Paper Feed Clutch	5-16	J7
Solenoids			
SOL1	Air Flow Valve Solenoid - M	2-7	F7
SOL2	Air Flow Valve Solenoid - C	2-8	F7
SOL3	Air Flow Valve Solenoid - Y	2-9	F7
SOL4	Air Flow Valve Solenoid - K	2-10	F7
SOL5	By-pass Pick-up Solenoid	4-5	E7
SOL6	Exit Junction Gate Solenoid	5-28	C5
SOL7	Oil Supply Unit Solenoid	6-5	C5
Lamps			
L1	Pressure Roller Fusing Lamp	3-5	C4
L2	Heating Roller Fusing Lamp	3-6	C4
Thermistors			
TH1	Thermistor 1	1-16	G5
TH2	Thermistor 2	1-9	G5
TH3	Heating Roller Thermistor	3-3	D4
TH4	Pressure Roller Thermistor	3-2	D4
Thermofuse/Stat			
THO1	Pressure Roller Thermofuse	3-1	C4
THO2	Heating Roller Thermostat	3-4	C4
H1	Anti-condensation Heater	-	E4

ELECTRICAL COMPONENT LAYOUT (G571)

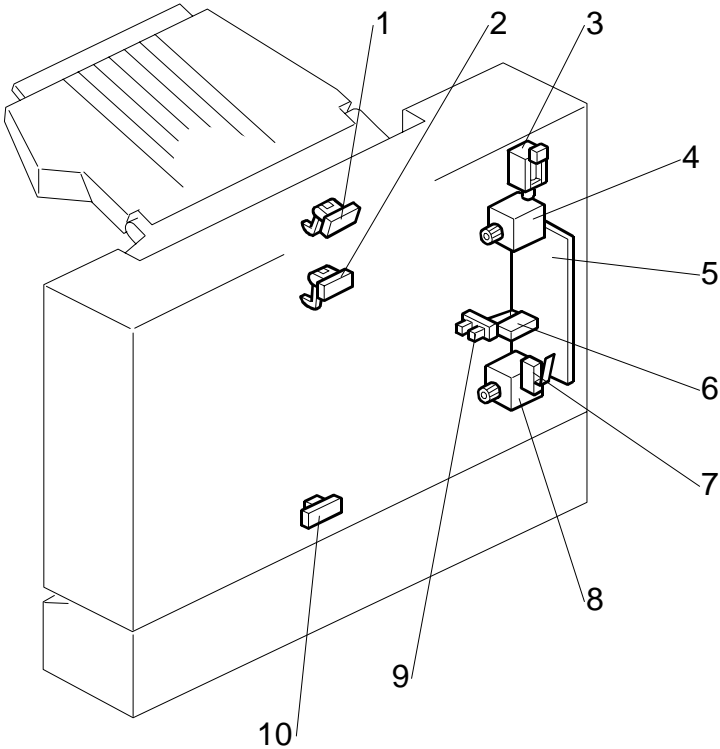

G571D102.WMF

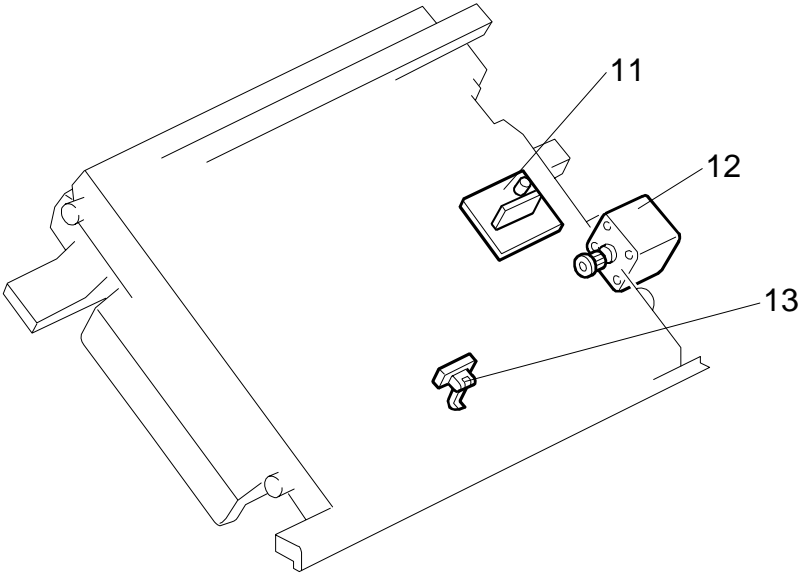

G571D103.WMF

ELECTRICAL COMPONENT DESCRIPTION (G571)

Symbol	Description	Index No.	P-to-P
Motors			
M1	Duplex inverter 1	4	F3
M2	Duplex inverter 2	8	F3
M3	Duplex feed	12	G1
Sensors			
S1	Exit 1	1	G3
S2	Duplex feed	13	G1
S3	Duplex inverter	10	G3
S4	Exit 2	2	G3
S5	Exit 3	9	G3
Solenoids			
SOL1	Junction gate	3	G3
Switches			
SW1	Duplex door	6	F3
SW2	Duplex inverter unit	7	G3
PCBs			
PCB1	Duplex control	5	F2
PCB2	Duplex drive	11	F1

POINT TO POINT WIRING DIAGRAM (One-tray Paper Feed Unit: G567)

Symbol Table

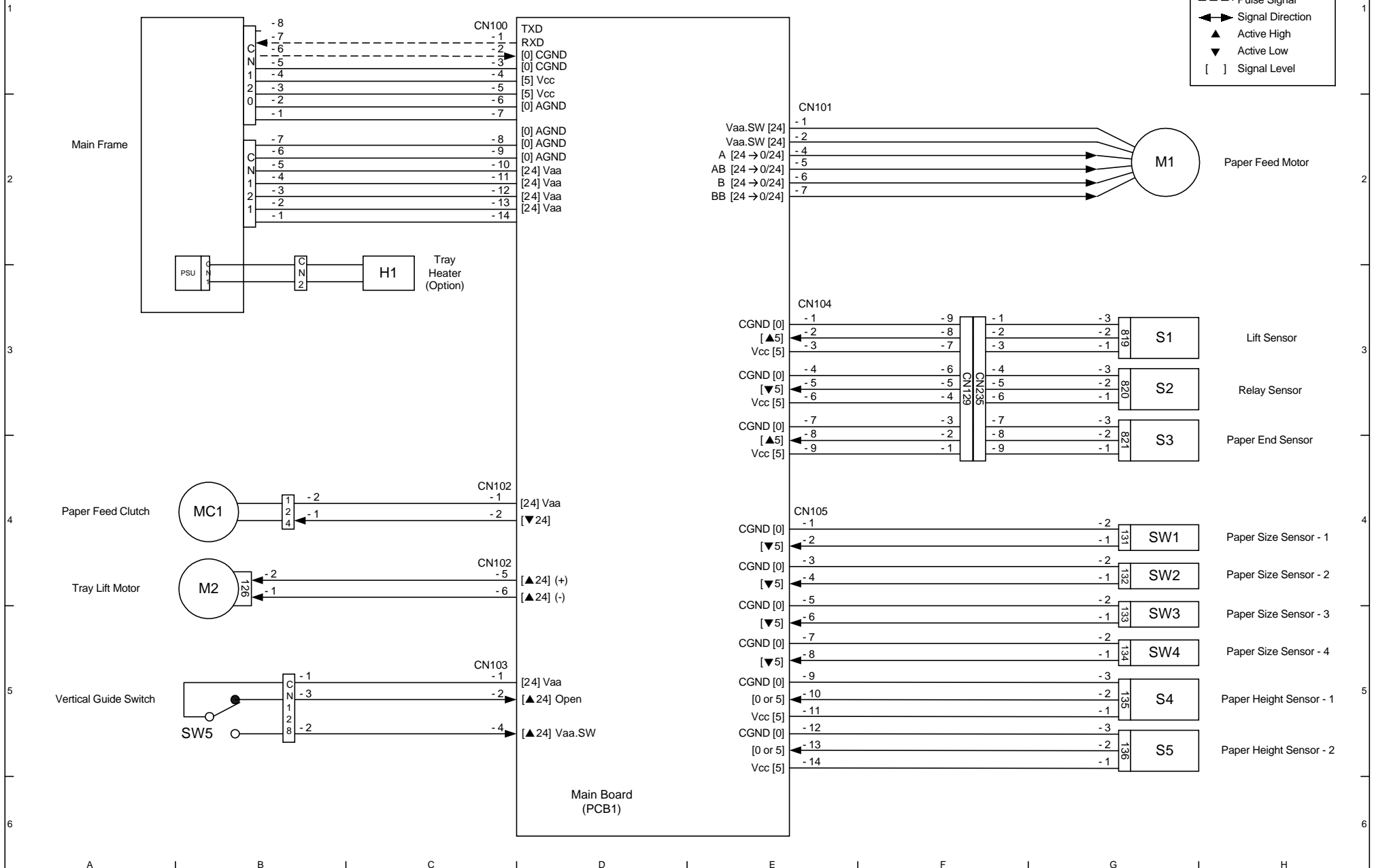
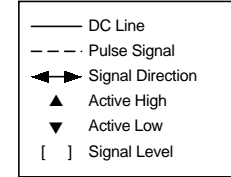

ELECTRICAL COMPONENT LAYOUT (G567)

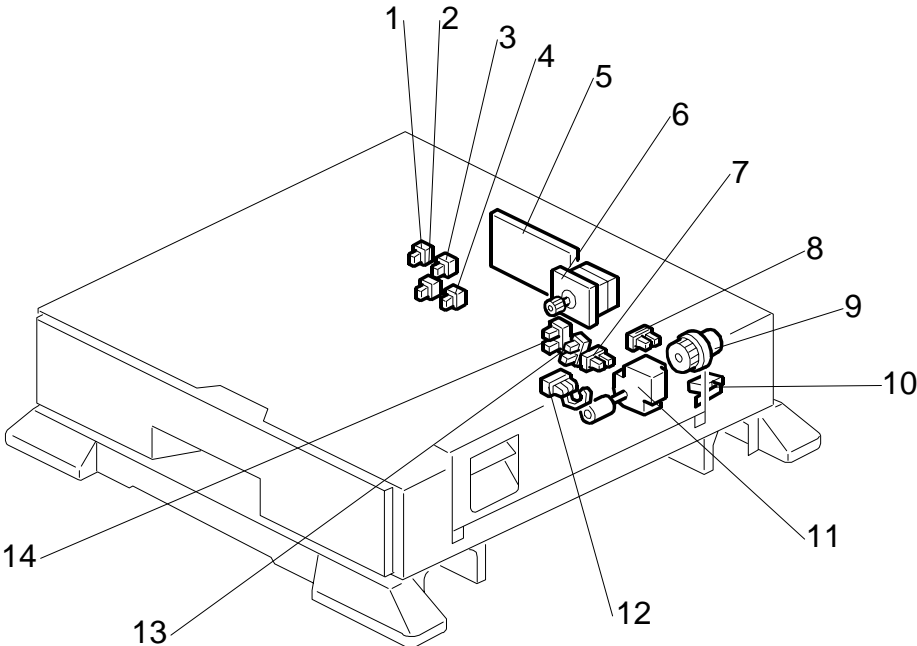

ELECTRICAL COMPONENT DESCRIPTION (G567)

Symbol	Description	Index No.	P-to-P
Motors			
M1	Paper Feed	6	G2
M2	Tray Lift	11	B4
Sensors			
S1	Lift	8	G3
S2	Relay	12	G3
S3	Paper End	7	G4
S4	Paper Height 1	14	G5
S5	Paper Height 2	13	G5
Switches			
SW1	Paper Size 1	1	G4
SW2	Paper Size 2	2	G4
SW3	Paper Size 3	3	G5
SW4	Paper Size 4	4	G5
SW5	Vertical Guide	10	B5
Magnetic Clutches			
MC1	Paper Feed	9	B4
PCBs			
PCB1	Main	5	D6
Heaters			
H1	Tray Heater (Option)	-	C2

POINT TO POINT WIRING DIAGRAM (Two-tray Paper Feed Unit: G568)

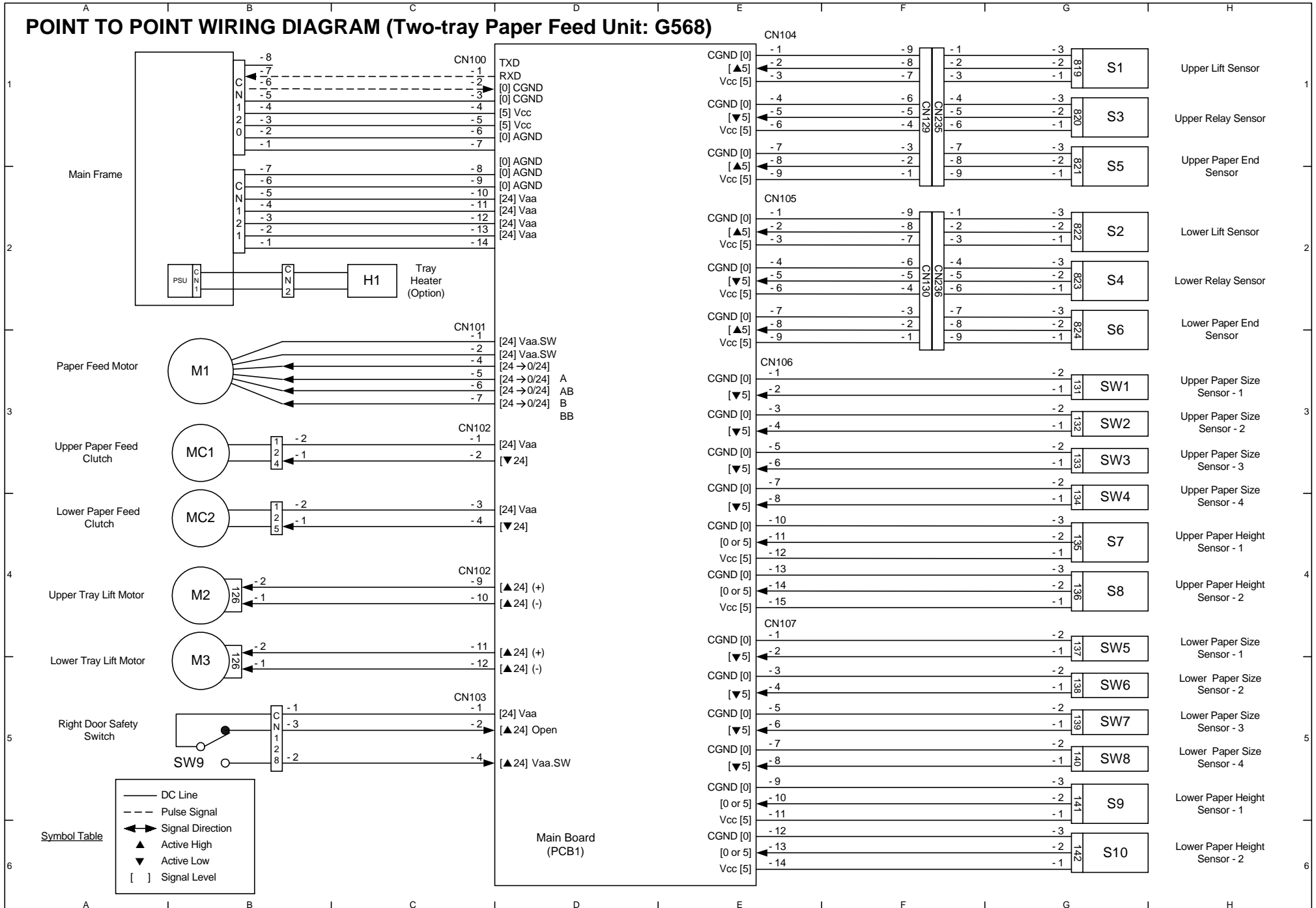

ELECTRICAL COMPONENT LAYOUT (G568)

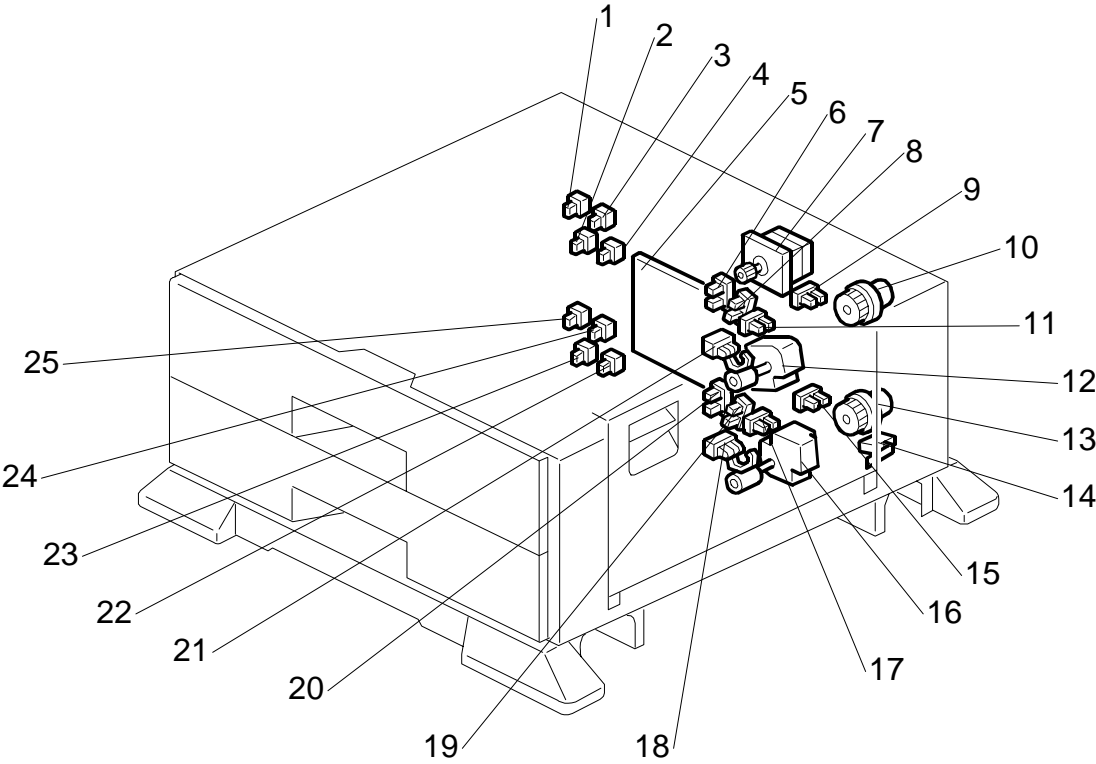

ELECTRICAL COMPONENT DESCRIPTION (G568)

Symbol	Description	Index No.	P-to-P
Motors			
M1	Paper Feed	7	B3
M2	Upper Tray Lift	12	B4
M3	Lower Tray Lift	16	B5
Sensors			
S1	Upper Lift	9	G1
S2	Lower Lift	15	G2
S3	Upper Relay	21	G1
S4	Lower Relay	18	G2
S5	Upper Paper End	11	G1
S6	Lower Paper End	17	G2
S7	Upper Paper Height 1	6	G4
S8	Upper Paper Height 2	8	G4
S9	Lower Paper Height 1	20	G5
S10	Lower Paper Height 2	19	G6
Switches			
SW1	Upper Paper Size 1	1	G3
SW2	Upper Paper Size 2	2	G3
SW3	Upper Paper Size 3	3	G3
SW4	Upper Paper Size 4	4	G4
SW5	Lower Paper Size 1	25	G4
SW6	Lower Paper Size 2	23	G5
SW7	Lower Paper Size 3	24	G5
SW8	Lower Paper Size 4	22	G5
SW9	Vertical Guide	14	B5
Motors			
MC1	Upper Paper Feed	10	B3
MC2	Lower Paper Feed	13	B4
PCBs			
PCB1	Main	5	D6
Heaters			
H1	Tray Heater (Option)	-	C2

POINT TO POINT WIRING DIAGRAM (Large Capacity Tray: G569)

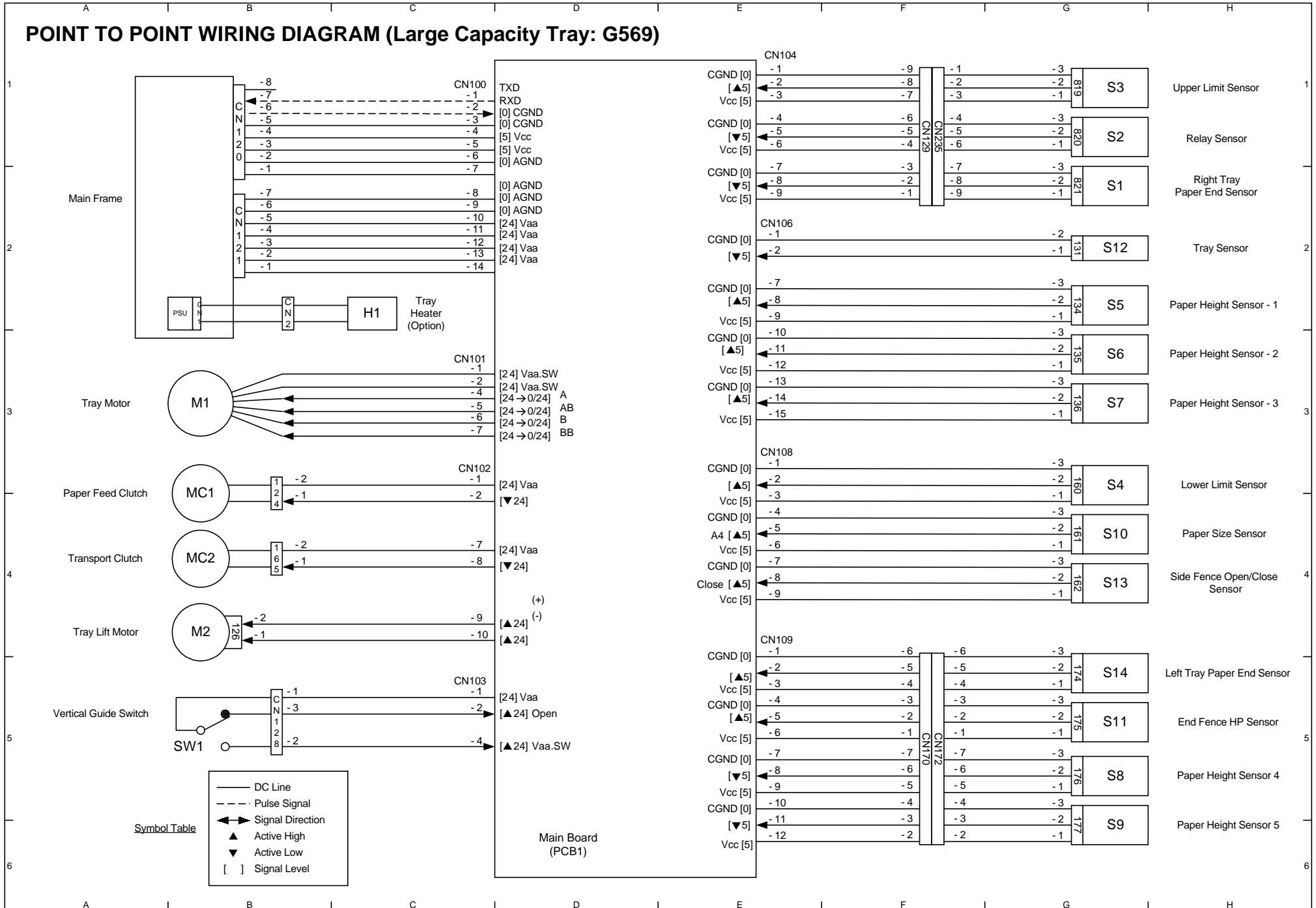

ELECTRICAL COMPONENT LAYOUT (G569)

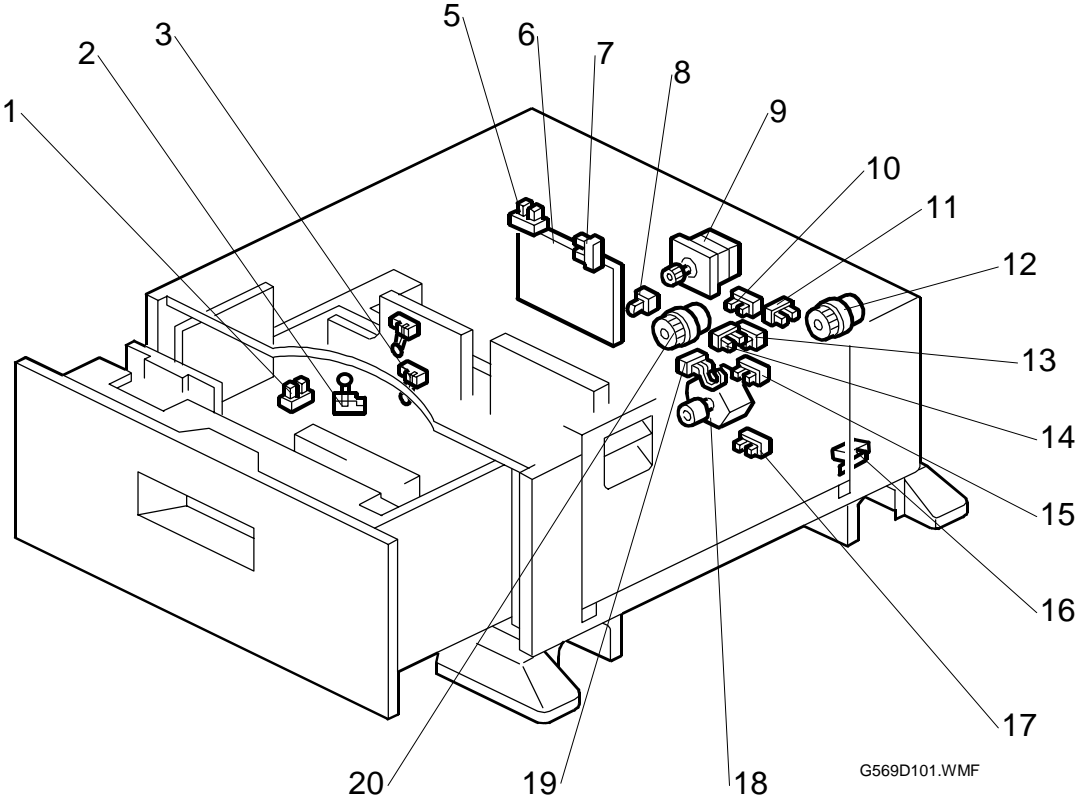

G569D101.WMF

ELECTRICAL COMPONENT DESCRIPTION (G569)

Symbol	Description	Index No.	P-to-P
M1	Tray Motor	9	B3
M2	Tray Lift Motor	18	B4
S1	Right Tray Paper End	14	G2
S2	Relay	19	G1
S3	Upper Limit	11	G1
S4	Lower Limit	17	G3
S5	Paper Height 1	10	G2
S6	Paper Height 2	13	G3
S7	Paper Height 3	15	G3
S8	Paper Height 4	3	G5
S9	Paper Height 5	4	G6
S10	Paper Size	5	G4
S11	End Fence Home Position	1	G5
S12	Tray	8	G2
S13	Side Fence Open/Closed	7	G4
S14	Left Tray Paper End	2	G5
SW1	Vertical Guide	16	B5
MC1	Paper Feed	12	B3
MC2	Stack Transport	20	B4
PCB1	Main	6	D6
H1	Tray Heater (Option)	-	C2

POINT TO POINT WIRING DIAGRAM (Two-tray Finisher: G565)

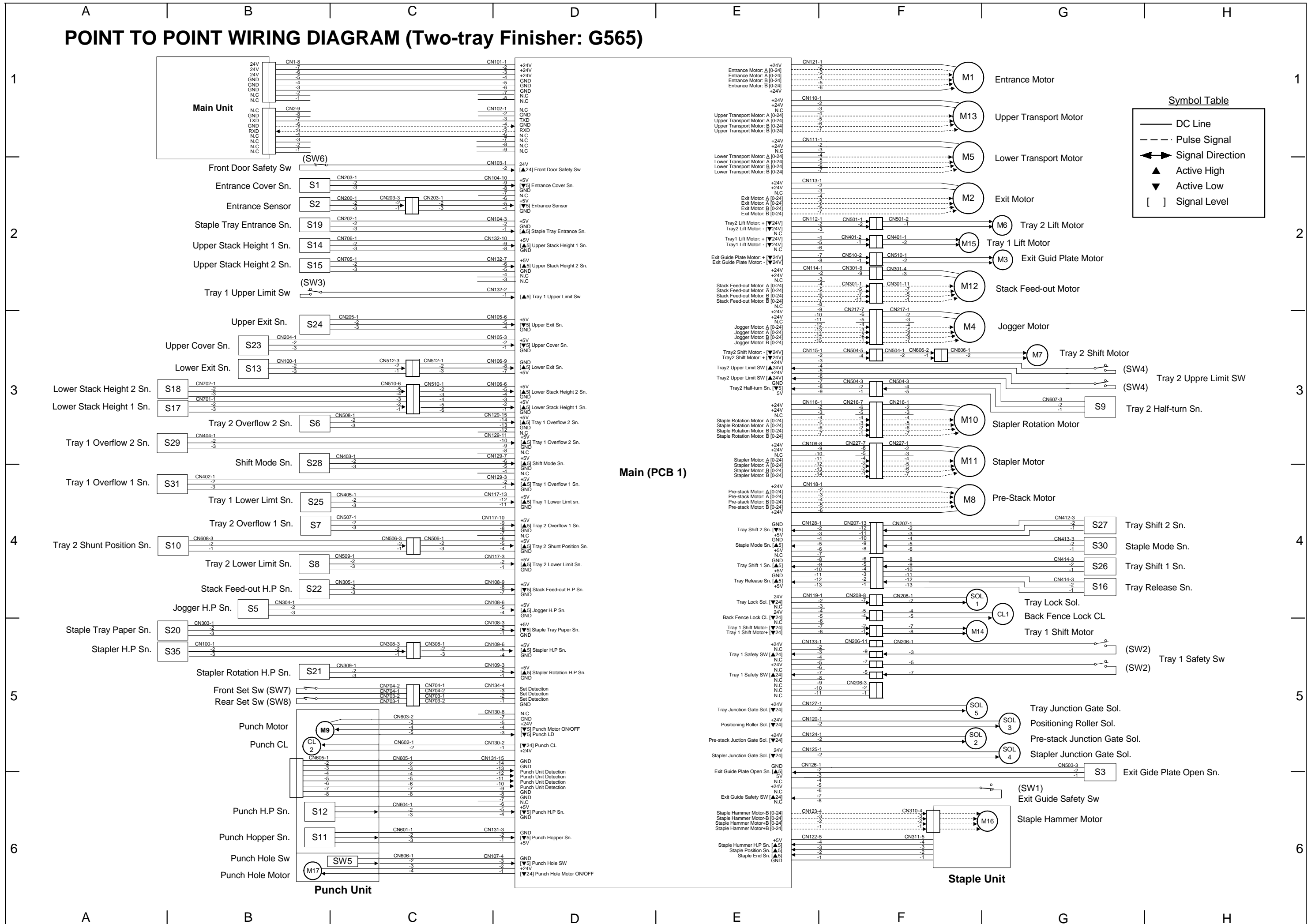

ELECTRICAL COMPONENT LAYOUT (G565)

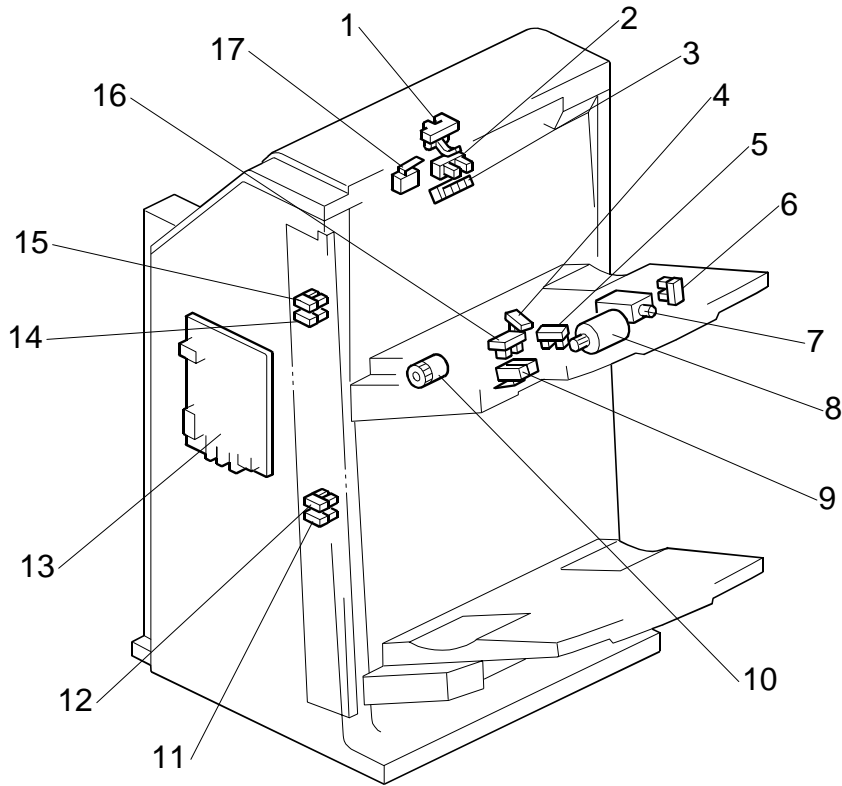

G565D901.WMF

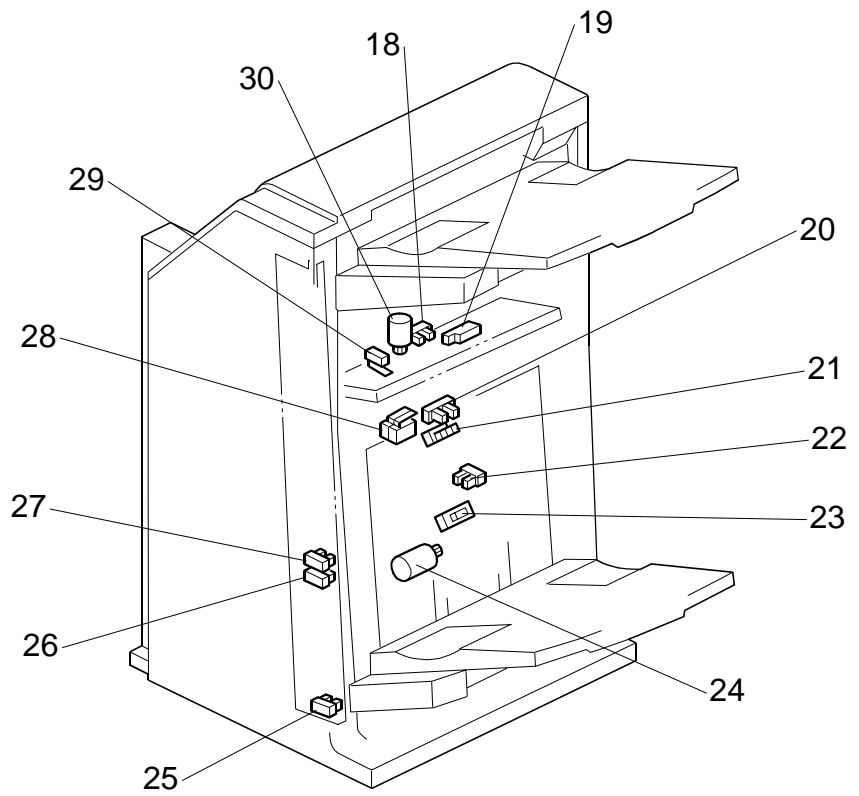

G565D902.WMF

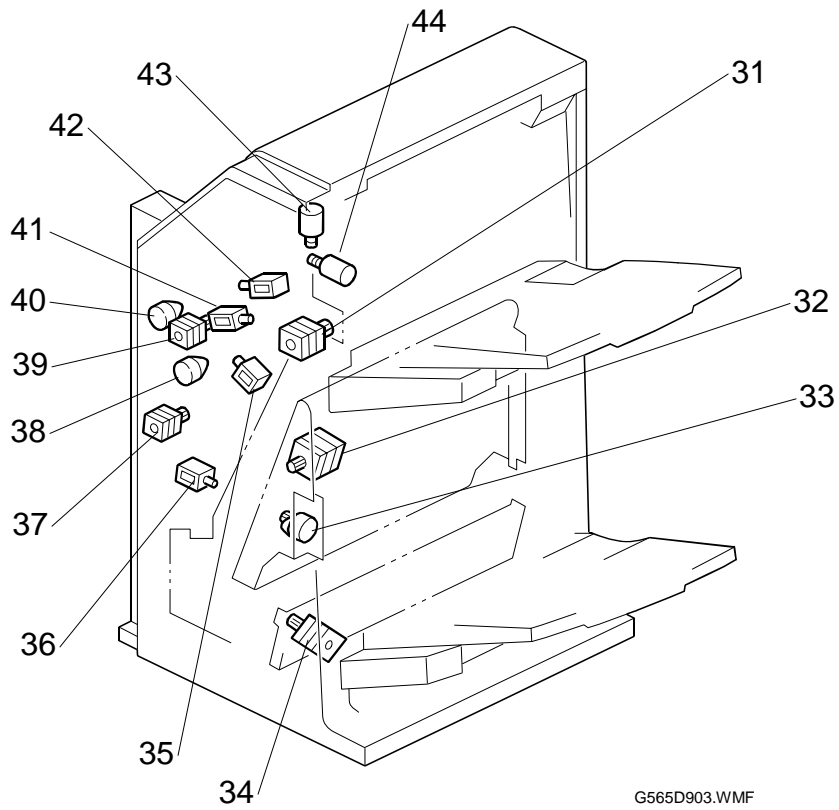

G565D903.WMF

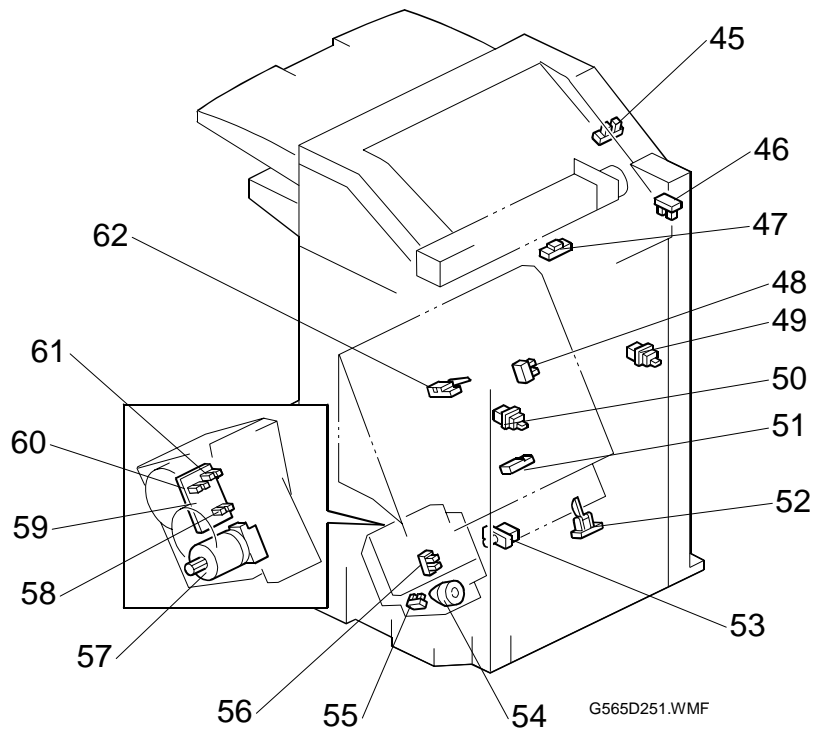

G565D251.WMF

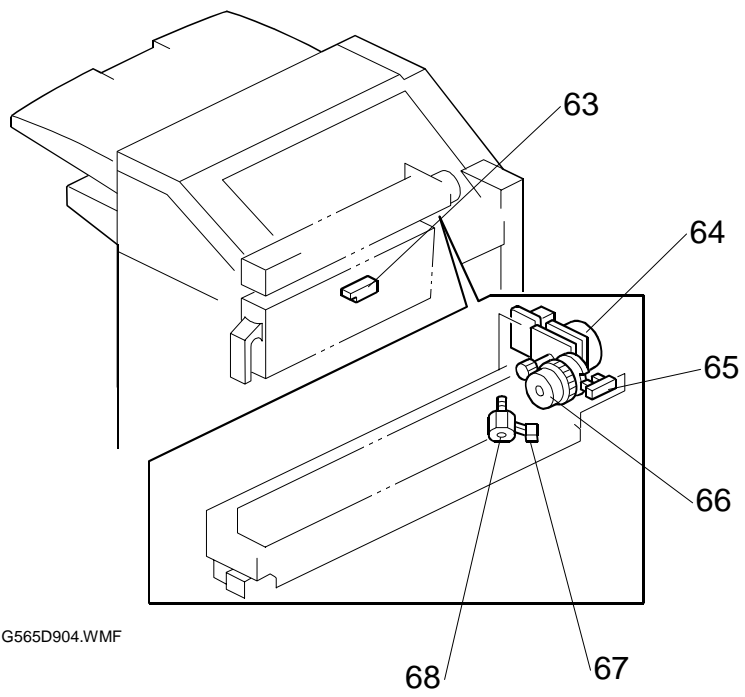

G565D904.WMF

ELECTRICAL COMPONENT DESCRIPTION (G565)

Symbol	Description	Index No.	P-to-P
Motors			
M1	Entrance	40	F1
M2	Exit	31	F2
M3	Exit guide plate	30	G2
M4	Jogger	33	F3
M5	Lower transport	37	F1
M6	Tray 2 lift	44	G2
M7	Tray 2 shift	24	G3
M8	Pre-stack	38	G4
M9	Punch	64	B5
M10	Stapler rotation	54	F3
M11	Stapler	34	F3
M12	Stack feed-out	32	F2
M13	Upper transport	39	F1
M14	Tray 1 shift	8	F5
M15	Tray 1 lift	43	F2
M16	Staple hammer	57	G6
M17	Punch hole	68	B6
Sensors			
S1	Entrance cover	46	B2
S2	Entrance	47	B2
S3	Exit guide plate open	18	G6
S4	Staple position	61	E6
S5	Jogger HP	48	B4
S6	Tray 2 overflow-2	26	B3
S7	Tray 2 overflow-1	27	B4
S8	Tray 2 lower limit	25	B4
S9	Tray 2 half-turn	22	G3
S10	Tray 2 shunt position	23	B4
S11	Punch hopper	63	B6
S12	Punch HP	65	B6
S13	Lower exit	19	B3
S14	Upper stack height 1	2	B2
S15	Upper stack height 2	3	B2
S16	Tray release	16	G4
S17	Lower stack height 1	20	B3
S18	Lower stack height 2	21	B3
S19	Staple tray entrance	52	B2
S20	Staple tray paper	51	B5
S21	Stapler rotation HP	55	B5
S22	Stack feed-out HP	62	B4
S23	Upper cover	45	B3
S24	Upper exit	1	B3
S25	Tray 1 lower limit	11	B4
S26	Tray shift 1	4	G4

Symbol	Description	Index No.	P-to-P
S27	Tray shift 2	5	G4
S28	Shift mode	14	B3
S29	Tray 1 overflow-2	12	B3
S30	Staple mode	6	G4
S31	Tray 1 overflow-1	15	B4
S32	Staple hammer HP	60	E6
S34	Staple end	58	E6
S35	Stapler HP	56	B5
Solenoids			
SOL1	Tray lock	7	F4
SOL2	Pre-stack junction gate	35	F5
SOL3	Positioning roller	36	G5
SOL4	Stapler junction gate	41	G5
SOL5	Tray junction gate	42	F5
Switches			
SW1	Exit guide safety	29	G6
SW2	Tray 1 safety	9	G5
SW3	Tray 1 upper limit	17	B2
SW4	Tray 2 upper limit	28	G3
SW5	Punch hole	67	C6
SW6	Front door safety	53	B2
SW7	Front set	50	B5
SW8	Rear set	49	B5
Electrical Clutches			
CL1	Back fence lock	10	G4
CL2	Punch	66	B5
PCBs			
PCB1	Main	13	D4
PCB2	Stapler Sensor	59	NA

POINT TO POINT WIRING DIAGRAM (Four-bin Mailbox: G566)

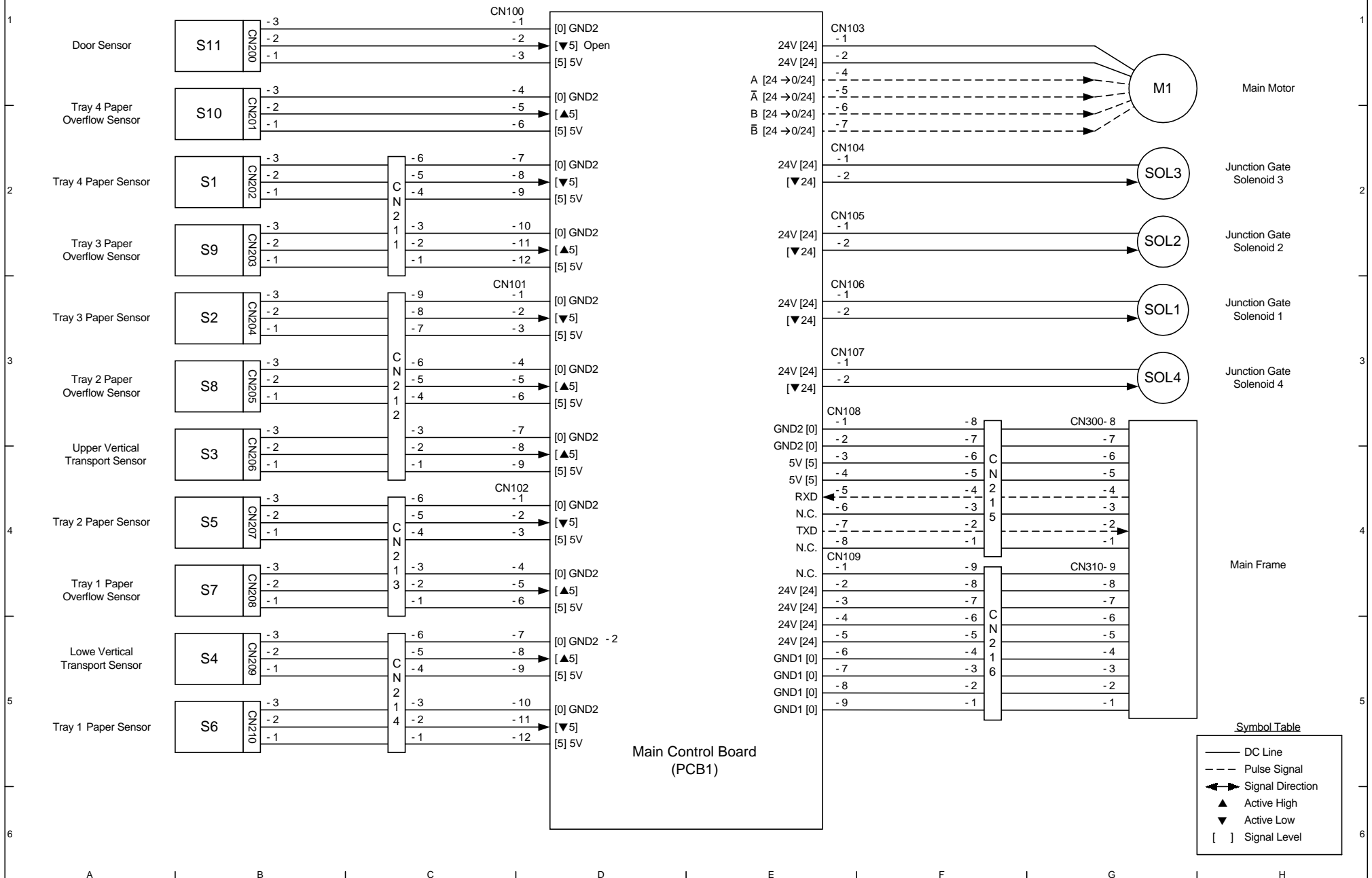

ELECTRICAL COMPONENT LAYOUT (G566)

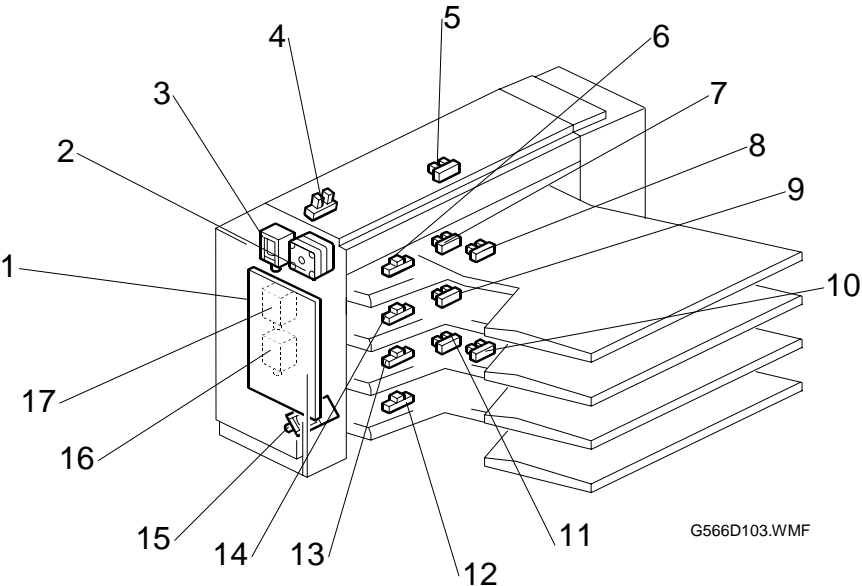

G566D103.WMF

ELECTRICAL COMPONENT DESCRIPTION (G566)

Symbols	Description	Index No.	P-to-P
Motors			
M1	Main	2	G1
Sensors			
S1	Tray 4 Paper	6	B2
S2	Tray 3 Paper	14	B3
S3	Upper Vertical Transport	8	B4
S4	Lower Vertical Transport	10	B5
S5	Tray 2 Paper	13	B4
S6	Tray 1 Paper	12	B5
S7	Tray 1 Paper Overflow	11	B4
S8	Tray 2 Paper Overflow	9	B3
S9	Tray 3 Paper Overflow	7	B2
S10	Tray 4 Paper Overflow	5	B2
S11	Door	4	B1
Solenoids			
SOL1	Junction Gate Solenoid 1	16	G3
SOL2	Junction Gate Solenoid 2	17	G2
SOL3	Junction Gate Solenoid 3	3	G2
SOL4	Junction Gate Solenoid 4	15	G3
PCBs			
PCB1	Main Control	1	E5